

Grundlegende Leistungsdaten - WAMAK WW 25 EVI

Heizen - EN 14511		
Wärmeleistung [kW]	W10 / W35 (max)	25.3
	W10 / W35 (min)	25.3
	W10 / W34	25.3
Leistungsaufnahme [kW]	W10 / W35 (max)	4.3
	W10 / W35 (min)	4.3
	W10 / W34	4.2 (6.4 / 6.4)
Leistungszahl Heizen [COP]	W10 / W35 (max)	5.90
	W10 / W35 (min)	5.90
	W10 / W34	6.03
Jahreszeitbedingte Raumheizungs-Energieeffizienz - SCOP EN 14825		
Klimazone Durchschnitt / Niedrigtemp. [35°C]	SCOP	6.65
	η [%]	266.1
	Label	A+++
	Qhe [kWh]	7817.5
	Pdesignh [kW]	25.3
	Tbivalent [°C]	-10
Kühlung		
Kühlleistung - [kW]	A35 / W23-18	19.9
	A25 / W23-18	20.9
	A35 / W12-7	14.8
	A25 / W12-7	14.8
Jahreszeitbedingte Raumkühlungs-Energieeffizienz - SEER EN 14825		
[W 23 / 18°C]	SEER	5.28
	Qce [kWh]	2107.5
	η_c [%]	211.3
Schall EN 12102		
Schalleistungspegel - Lw	dB(A)	47.1
Schalldruckpegel - Lp	1 m dB(A)	39.1
	5 m dB(A)	25.1
	10 m dB(A)	19.1
Mechanische und Betriebs-Informationen		
Verdichterbauart (3~ 400/50)	SCROLL / 1 /	Ein/Aus
Kältemittel	R410A (GWP - 2088)	3 kg
Einsatzgrenze Heizungswasser - (min / max) [°C]		25 / 65
Einsatzgrenze Wärmequelle - (min / max) [°C]		-10 (7) / 30
Gewicht		180 kg

Wichtigste technische Daten - WAMAK WW 25 EVI

Gehäuse Bezeichnung			VN800			Daten von Wärmeabgabe			
Grundlegende Abmessungen	Hohe [mm]	1270	Einsatzgrenze	MAX [°C]	65	genauer siehe Betriebsgrenzendiagramm			
	Breite [mm]	850	Heizungswasser	MIN [°C]	25				
	Länge [mm]	630	Kondensator			Anschlussdimension	1.1/2 "		
Gewicht [kg]	180				Bauart	BPHE			
Gehäuse Farbe	Grau				Anzahl	1			
Gehäuse IP Klasse	IP20				Material	AISI 316			
Kältekreis						Maximaler Überdruck - Kältemittel [bar]			45
Verdichter	Bauart	Scroll				Maximaler Überdruck - Wasser [bar]			6
	Leistungstufen	1				Prüfdruck [bar]			70
	Ein/Aus					Wärmeträger			Wasser
	Leistungsfaktor Cosφ	0.64				Volumenstrom @ dT 5K (nom) - Wasser [m3/h]			4.36
	Wicklungswiderstand	1.79 Ohm				Interne Druckdifferenz - Wasser [kPa]			12
Kältemittel		R410A				ECM Kondensator-pumpe			UPMXL GEO 32-125
	Menge	3 kg				Temperaturdifferenz @ 35°C (nom)			5 K
	GWP	2088				@ 55°C			8 K
	Sicherheitsklasse	A1				@ 65°C			10 K
Kältemittelöl	POE RL32-3MAF					Daten von Erneuerbarer Energiequelle			
	Ölmenge	1.24 L				Einsatzgrenze	MIN [°C]	-10 (7)	
Maximaler Hochdruck - Kältemittel [bar]		45				Wärmequelle	MAX [°C]	30	
	PED Klasse	1				genauer siehe Betriebsgrenzendiagramm			
EVI - Dampfeinspritzung mit Ekonomiser						Verdampfer	Anschlussdimension	1.1/2 "	
Daten von Elektroanschluss							Bauart	BPHE	
Einspeisung [#~ V/Hz]	3~ 400/50						Anzahl	1	
Strom	Nominal [A]	9.32				Material	AISI 316		
	Maximal [A]	16.00				Maximaler Überdruck - Kältemittel [bar]			28
	Start [A]	18.9				Wärmeträger			Wasser
Sanftanlasser	MCI 15					Maximaler Überdruck - Wasser [bar]			6
Hauptsicherung	C25					Volumenstrom - Wasser [m3/h]			6.05
Steuerungssystem						Interne Druckdifferenz - Wasser [kPa]			20
Hauptregler	SIEMENS	RVS 21 AVS 55.199				Temperaturdifferenz - Wasser			3 K
Erweiterungsmo dul	AVS75.391	AVS75.391	AVS75.3xx						
Bus Clip-In		LPB OCI347	Modbus OCI353						
Online-Verbindung		Web server OZW672	ToSyMo						

*** mit Zubehör

WAMAK WW 25 EVI

ErP (EU) No 811/2013: Technische Parameter für Wärmepumpen-Raumheizgeräte

Modell	WW 25 EVI
Luft-Wasser-Wärmepumpe	nein
Sole/Wasser-Wärmepumpe	nein
Wasser/Wasser-Wärmepumpe	ja
Niedertemperatur-Wärmepumpe	nein
Ausgestattet mit einer Zusatzheizung	nein
Wärmepumpen-Kombi-Heizgerät	nein
Temperaturanwendung	niedrig (35 °C - 30 °C)
Klimaverhältnisse	durchschnittlich

Angabe	Symbol	Wert	Ein.	Angabe	Symbol	Wert	Ein.
Nennwärmeleistung bei Tdesignh	Prated	25.3	kW	Jahreszeitbedingte Raumheizungs-Energieeffizienz	η_s	266.1	%
Ausgewiesene Heizleistung für Teillast bei einer Innentemperatur von 20 °C und einer Außentemperatur von Tj				Deklarierte Leistungszahl oder Primärenergiekennzahl für Teillast bei einer Innentemperatur von 20 °C und einer Außentemperatur von Tj			
Tj = -7 °C	Pdh	25.3	kW	Tj = -7 °C	COPd	6.03	-
Tj = +2 °C	Pdh	25.3	kW	Tj = +2 °C	COPd	6.6	-
Tj = +7 °C	Pdh	25.4	kW	Tj = +7 °C	COPd	7.0	-
Tj = +12 °C	Pdh	25.4	kW	Tj = +12 °C	COPd	7.5	-
Tj = bivalente Temperatur	Pdh	25.3	kW	Tj = bivalente Temperatur	COPd	5.9	-
Tj = Betriebsgrenztemperatur	Pdh	---	kW	Tj = Betriebsgrenztemperatur	COPd	---	-
Bivalente Temperatur	Tbiv	-10	°C	Tj = Betriebsgrenztemperatur	TOL	---	°C
Stromverbrauch in anderen Modi als dem aktiven Modus				Betriebsgrenztemperatur des Heizwassers	WTOL	65	°C
Aus-Zustand	Poff	0.010	kW	Zusatzheizung			
Thermostat-Aus-Modus	Pto	0.010	kW	Nennwärmeleistung	Psup	3.9	kW
Standby-Betrieb	Psb	0.010	kW	Art der Energiezufuhr	elektrisch		
Betriebsart Kurbelwannenheizung	Pck	0.000	kW				
Sonstige Angaben							
Leistungsregelung	fest			Für Luft/Wasser-Wärmepumpen: Nennluftvolumenstrom, Außenbereich	-	---	m ³ /h
Schalleistungspegel				Für Wasser- oder Sole/Wasser-Wärmepumpen: Nenndurchfluss der Sole oder des Wassers, Wärmetauscher im Freien	-	6.05	m ³ /h
in Innenräumen	Lwa	47	dB				
im Freien	Lwa	---	dB				
Jährlicher Energieverbrauch	Q _{HE}	7817.5	kWh				

Angaben zum Kontakt: WAMAK, s.r.o., Orovnica 252, 96652, Orovnica, Slovakia, info@wamak.sk

WAMAK WW 25 EVI

ErP (EU) No 811/2013: Technische Parameter für Wärmepumpen-Raumheizgeräte

Modell	WW 25 EVI
Luft-Wasser-Wärmepumpe	nein
Sole/Wasser-Wärmepumpe	nein
Wasser/Wasser-Wärmepumpe	ja
Niedertemperatur-Wärmepumpe	nein
Ausgestattet mit einer Zusatzheizung	nein
Wärmepumpen-Kombi-Heizgerät	nein
Temperaturanwendung	mittel (55 °C - 47 °C)
Klimaverhältnisse	durchschnittlich

Angabe	Symbol	Wert	Ein.	Angabe	Symbol	Wert	Ein.
Nennwärmeleistung bei Tdesignh	Prated	25.6	kW	Jahreszeitbedingte Raumheizungs-Energieeffizienz	η_s	202.5	%
Ausgewiesene Heizleistung für Teillast bei einer Innentemperatur von 20 °C und einer Außentemperatur von Tj				Deklarierte Leistungszahl oder Primärenergiekennzahl für Teillast bei einer Innentemperatur von 20 °C und einer Außentemperatur von Tj			
Tj = -7 °C	Pdh	25.8	kW	Tj = -7 °C	COPd	4.02	-
Tj = +2 °C	Pdh	25.6	kW	Tj = +2 °C	COPd	5.3	-
Tj = +7 °C	Pdh	25.6	kW	Tj = +7 °C	COPd	6.0	-
Tj = +12 °C	Pdh	25.6	kW	Tj = +12 °C	COPd	6.7	-
Tj = bivalente Temperatur	Pdh	25.6	kW	Tj = bivalente Temperatur	COPd	3.6	-
Tj = Betriebsgrenztemperatur	Pdh	---	kW	Tj = Betriebsgrenztemperatur	COPd	---	-
Bivalente Temperatur	Tbiv	-10	°C	Tj = Betriebsgrenztemperatur	TOL	---	°C
Stromverbrauch in anderen Modi als dem aktiven Modus				Betriebsgrenztemperatur des Heizwassers			
Aus-Zustand	Poff	0.010	kW	Zusatzheizung			
Thermostat-Aus-Modus	Pto	0.010	kW	Nennwärmeleistung	Psup	3.9	kW
Standby-Betrieb	Psb	0.010	kW	Art der Energiezufuhr			
Betriebsart Kurbelwannenheizung	Pck	0.000	kW	elektrisch			
Sonstige Angaben				Für Luft/Wasser-Wärmepumpen: Nennluftvolumenstrom, Außenbereich			
Leistungsregelung		fest		Für Wasser- oder Sole/Wasser-Wärmepumpen: Nenndurchfluss der Sole oder des Wassers, Wärmetauscher im Freien			
Schalleistungspegel							
in Innenräumen	Lwa	47	dB				
im Freien	Lwa	---	dB				
Jährlicher Energieverbrauch	QHE	10406.1	kWh				

Angaben zum Kontakt: WAMAK, s.r.o., Orovnic 252, 96652, Orovnic, Slovakia, info@wamak.sk



ENERG Y IIA
 енергия - ενεργεια IE IA



WW 25 EVI

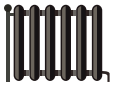

55 °C

35 °C

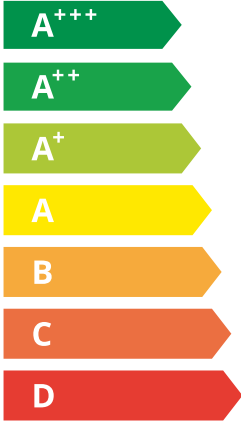

A+++

A+++



47 dB



--- dB

■ 27	■ 26
■ 26	■ 26
■ 26	■ 25
kW	kW



2019

811/2013

WW 25 EVI

ErP Data

	55 °C	35 °C
Energy class	A+++	A+++
η [%]	202.5	266.1
P_{rated} [kW]	26	26
Q_{HE} [kWh/y]	10407	7818
SCOP [-]	5.06	6.65
$T_{bivalent}$ [°C]	-10	-10

CONTROLLER



+ QAA55/75	class VII	3.5% ↓
- QAA55/75	class III	1.5% ↓

Heizleistung Daten

Version: v2024.010-BW-WW

Quelle - Sole [0°C] / Niedrigtemp. [35°C]

ZHI18K1P-TFM_R410A_1_BWW

Betriebsbedingungen	Qh	P	COP
1 B0 / W30-35	20.0	4.3	4.61
2 B0 / W30-35 (MIN)	20.0	4.3	4.61
A B0 / Wxx-34	19.9	4.2	4.72
B B0 / Wxx-30	19.9	3.9	5.15
C B0 / Wxx-27	19.8	3.6	5.50
D B0 / Wxx-24	19.8	3.4	5.85
E B0 / Wxx-35	20.0	4.3	4.61
F B0 / Wxx-35	20.0	4.3	4.61

SCOP DATA EN 14825:2018	
Quelle - Sole [0°C] / Niedrigtemp. [35°C]	
SCOPon	5.22
SCOPnet	5.22
SCOP	5.20
η [%]	207.87
Label	A+++
Qh [kWh]	7911
Pdesignh [kW]	20.0
Tbivalent [°C]	-10

Quelle - Sole [0°C] / Mitteltemp.. [55°C]

Betriebsbedingungen	Qh	P	COP
1 B0 / W47-55	20.7	7.1	2.92
2 B0 / W47-55 (MIN)	20.7	6.9	2.92
A B0 / Wxx-52	20.7	6.4	3.34
B B0 / Wxx-42	20.6	4.9	4.27
C B0 / Wxx-36	20.2	4.3	4.72
D B0 / Wxx-30	20.1	3.9	5.22
E B0 / Wxx-55	20.7	7.1	2.92
F B0 / Wxx-54	20.8	6.6	3.16

SCOP DATA EN 14825:2018	
Quelle - Sole [0°C] / Mitteltemp.. [55°C]	
SCOPon	4.13
SCOPnet	4.13
SCOP	4.11
η [%]	164.49
Label	A+++
Qh [kWh]	10359
Pdesignh [kW]	20.7
Tbivalent [°C]	-10

Quelle - Wasser [10°C] / Niedrigtemp. [35°C]

Betriebsbedingungen	Qh	P	COP
1 W10 / W30-35	25.3	4.3	5.90
2 W10 / W30-35 (MIN)	25.3	4.3	5.90
A W10 / Wxx-34	25.3	4.2	6.03
B W10 / Wxx-30	25.3	3.8	6.60
C W10 / Wxx-27	25.4	3.6	7.04
D W10 / Wxx-24	25.4	3.4	7.47
E W10 / Wxx-35	25.3	4.3	5.90
F W10 / Wxx-35	25.3	4.3	5.90

SCOP DATA EN 14825:2018	
Quelle - Wasser [10°C] / Niedrigtemp. [35°C]	
SCOPon	6.69
SCOPnet	6.69
SCOP	6.65
η [%]	266.09
Label	A+++
Qh [kWh]	7817
Pdesignh [kW]	25.3
Tbivalent [°C]	-10.00

Quelle - Wasser [10°C] / Mitteltemp. [55°C]

Betriebsbedingungen		Qh	P	COP
1	W10 / W47-55	25.6	7.1	3.60
2	W10 / W47-55 (MIN)	25.6	7.1	3.60
A	W10 / Wxx-52	25.8	6.4	4.02
B	W10 / Wxx-42	25.6	4.8	5.29
C	W10 / Wxx-36	25.6	4.2	6.04
D	W10 / Wxx-30	25.6	3.8	6.68
E	W10 / Wxx-55	25.6	7.1	3.60
F	W10 / Wxx-55	25.6	7.1	3.60

SCOP DATA EN 14825:2018	
Quelle - Wasser [10°C] / Mitteltemp. [55°C]	
SCOPon	5.08
SCOPnet	5.08
SCOP	5.06
η [%]	202.52
Label	A+++
Qh [kWh]	10406
Pdesignh [kW]	25.6
Tbivalent [°C]	-10.00

Niedrigtemperatur Kühlung W 12 / 7°C

Betriebsbedingungen		Qc	P	EER
A	W30-35 / W12-7	15.2	4.6	3.27
B	W26-xx / W12-7	15.5	4.2	3.67
C	W22-xx / W12-7	15.8	3.9	4.09
D	W18-xx / W12-7	15.9	3.7	4.31

SEER DATA EN 14825:2018 [W 12 / 7°C]	
SEERon	3.96
SEER	3.95
Qc [kWh]	8880
η [%]	157.86

Flächenkühlung W 23 / 18°C

Betriebsbedingungen		Qc	P	EER
A	W50-xx / W23-18	18.1	7.6	2.37
B	W40-xx / W23-18	19.3	5.9	3.25
C	W30-35 / W23-18	20.4	4.6	4.39
D	W26-xx / W23-18	20.8	4.2	4.91

SEER DATA EN 14825:2018 [W 23 / 18°C]	
SEERon	5.30
SEER	5.28
Qc [kWh]	8880
η [%]	211.30

Leistungslinien - Heizen

- Qh-nom-35 — Qh-min-35 - - - Qh-max-65 — Qh-nom-45 — Qh-nom-55
- Qh-nom-65

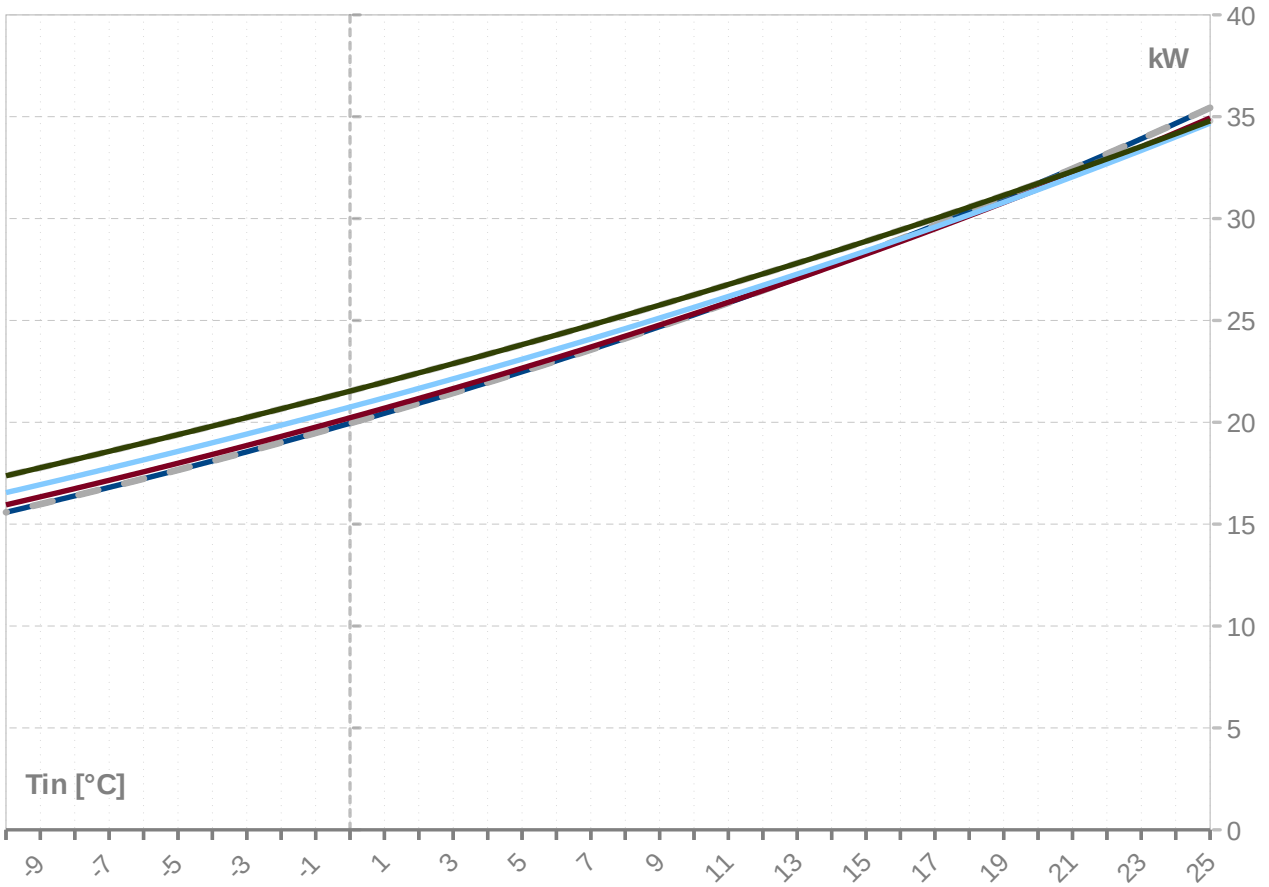

Leistungslinien - Kühlen

- Qc-nom-12-7 — Qc-nom-23-18

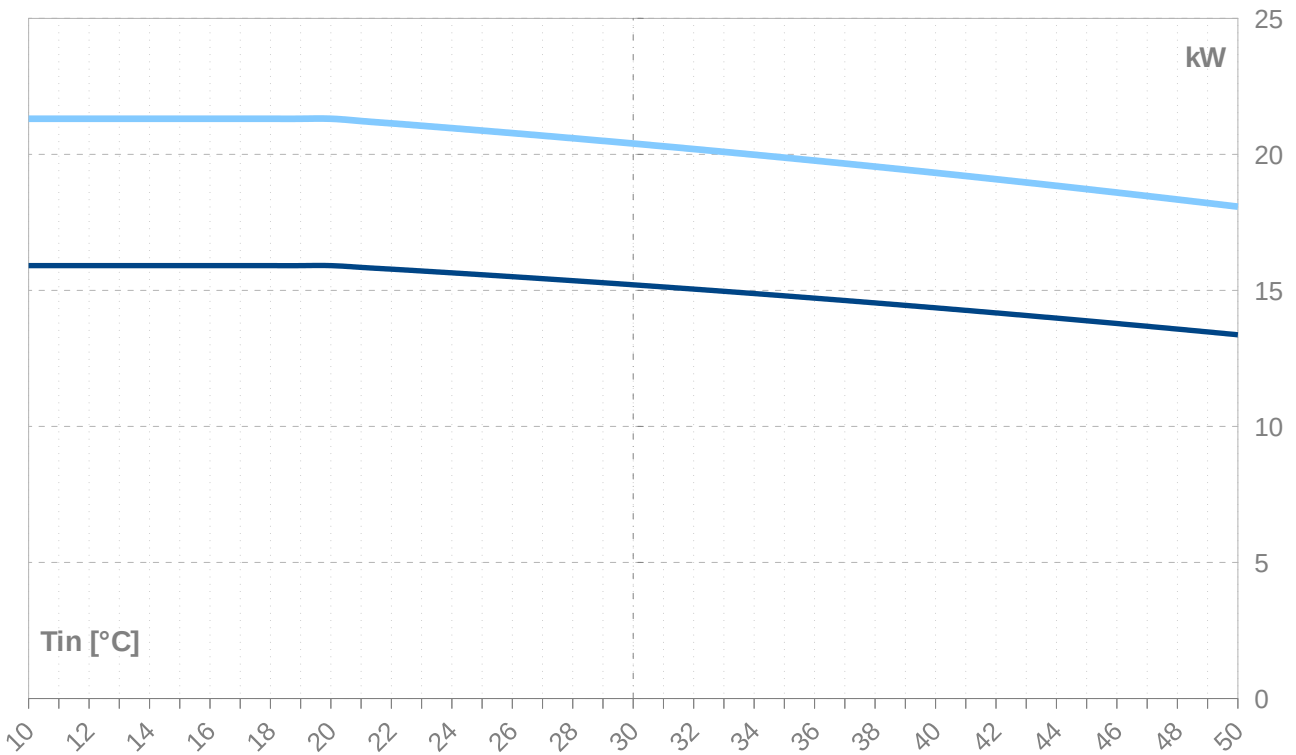

Tws -VL		35										
	[°C]	Qh nom	Qh min	Qh max	Pin nom	Pin min	Pin max	COP nom	Qc nom	Qc min	Qc max	I nom
	[°C]	[kW]	[kW]	[kW]	[kW]	[kW]	[kW]	kw / kw	[kW]	[kW]	[kW]	[A]
25		35.4	35.4	35.4	4.3	4.3	4.3	8.27	31.4	31.4	31.4	9.3
24		34.7	34.7	34.7	4.3	4.3	4.3	8.10	30.7	30.7	30.7	9.3
23		33.9	33.9	33.9	4.3	4.3	4.3	7.93	29.9	29.9	29.9	9.3
22		33.2	33.2	33.2	4.3	4.3	4.3	7.76	29.2	29.2	29.2	9.3
21		32.4	32.4	32.4	4.3	4.3	4.3	7.60	28.5	28.5	28.5	9.3
20		31.7	31.7	31.7	4.3	4.3	4.3	7.43	27.7	27.7	27.7	9.3
19		31.0	31.0	31.0	4.3	4.3	4.3	7.27	27.0	27.0	27.0	9.3
18		30.3	30.3	30.3	4.3	4.3	4.3	7.11	26.4	26.4	26.4	9.3
17		29.7	29.7	29.7	4.3	4.3	4.3	6.95	25.7	25.7	25.7	9.3
16		29.0	29.0	29.0	4.3	4.3	4.3	6.79	25.0	25.0	25.0	9.3
15		28.3	28.3	28.3	4.3	4.3	4.3	6.64	24.4	24.4	24.4	9.3
14		27.7	27.7	27.7	4.3	4.3	4.3	6.48	23.7	23.7	23.7	9.3
13		27.1	27.1	27.1	4.3	4.3	4.3	6.33	23.1	23.1	23.1	9.3
12		26.5	26.5	26.5	4.3	4.3	4.3	6.18	22.5	22.5	22.5	9.3
11		25.9	25.9	25.9	4.3	4.3	4.3	6.04	21.9	21.9	21.9	9.3
10		25.3	25.3	25.3	4.3	4.3	4.3	5.90	21.3	21.3	21.3	9.3
9		24.7	24.7	24.7	4.3	4.3	4.3	5.76	20.7	20.7	20.7	9.4
8		24.1	24.1	24.1	4.3	4.3	4.3	5.62	20.1	20.1	20.1	9.4
7		23.6	23.6	23.6	4.3	4.3	4.3	5.48	19.6	19.6	19.6	9.4
6		23.0	23.0	23.0	4.3	4.3	4.3	5.35	19.0	19.0	19.0	9.4
5		22.5	22.5	22.5	4.3	4.3	4.3	5.22	18.5	18.5	18.5	9.4
4		22.0	22.0	22.0	4.3	4.3	4.3	5.09	17.9	17.9	17.9	9.4
3		21.4	21.4	21.4	4.3	4.3	4.3	4.97	17.4	17.4	17.4	9.4
2		20.9	20.9	20.9	4.3	4.3	4.3	4.85	16.9	16.9	16.9	9.4
1		20.4	20.4	20.4	4.3	4.3	4.3	4.73	16.4	16.4	16.4	9.4
0		20.0	20.0	20.0	4.3	4.3	4.3	4.61	15.9	15.9	15.9	9.4
-1		19.5	19.5	19.5	4.3	4.3	4.3	4.50	15.4	15.4	15.4	9.4
-2		19.0	19.0	19.0	4.3	4.3	4.3	4.39	15.0	15.0	15.0	9.4
-3		18.5	18.5	18.5	4.3	4.3	4.3	4.28	14.5	14.5	14.5	9.4
-4		18.1	18.1	18.1	4.3	4.3	4.3	4.17	14.0	14.0	14.0	9.4
-5		17.7	17.7	17.7	4.3	4.3	4.3	4.07	13.6	13.6	13.6	9.4
-6		17.2	17.2	17.2	4.3	4.3	4.3	3.97	13.2	13.2	13.2	9.4
-7		16.8	16.8	16.8	4.3	4.3	4.3	3.87	12.7	12.7	12.7	9.4
-8		16.4	16.4	16.4	4.3	4.3	4.3	3.77	12.3	12.3	12.3	9.4
-9		16.0	16.0	16.0	4.3	4.3	4.3	3.68	11.9	11.9	11.9	9.4
-10		15.6	15.6	15.6	4.3	4.3	4.3	3.59	11.5	11.5	11.5	9.4
-11		15.2	15.2	15.2	4.3	4.3	4.3	3.50	11.1	11.1	11.1	9.4
-12		14.8	14.8	14.8	4.3	4.3	4.3	3.41	10.8	10.8	10.8	9.4
-13		14.4	14.4	14.4	4.3	4.3	4.3	3.33	10.4	10.4	10.4	9.4
-14		14.1	14.1	14.1	4.3	4.3	4.3	3.25	10.0	10.0	10.0	9.4
-15		13.7	13.7	13.7	4.3	4.3	4.3	3.17	9.7	9.7	9.7	9.4

-- Achtung: Betriebsgrenzen beachten - nicht in Tabelle festgehalten

ZHI18K1P-TFM_R410A_1_BWW

Tws -VL	45										
[°C]	Qh nom	Qh min	Qh max	Pin nom	Pin min	Pin max	COP nom	Qc nom	Qc min	Qc max	I nom
[°C]	[kW]	[kW]	[kW]	[kW]	[kW]	[kW]	kW / kW	[kW]	[kW]	[kW]	[A]
25	34.9	34.9	34.9	5.3	5.3	5.3	6.57	30.0	30.0	30.0	10.4
24	34.2	34.2	34.2	5.3	5.3	5.3	6.43	29.2	29.2	29.2	10.4
23	33.5	33.5	33.5	5.3	5.3	5.3	6.29	28.5	28.5	28.5	10.4
22	32.8	32.8	32.8	5.3	5.3	5.3	6.15	27.8	27.8	27.8	10.4
21	32.1	32.1	32.1	5.3	5.3	5.3	6.02	27.1	27.1	27.1	10.4
20	31.4	31.4	31.4	5.3	5.3	5.3	5.88	26.5	26.5	26.5	10.4
19	30.8	30.8	30.8	5.4	5.4	5.4	5.75	25.8	25.8	25.8	10.4
18	30.1	30.1	30.1	5.4	5.4	5.4	5.62	25.1	25.1	25.1	10.4
17	29.5	29.5	29.5	5.4	5.4	5.4	5.50	24.5	24.5	24.5	10.4
16	28.9	28.9	28.9	5.4	5.4	5.4	5.37	23.8	23.8	23.8	10.4
15	28.2	28.2	28.2	5.4	5.4	5.4	5.25	23.2	23.2	23.2	10.4
14	27.6	27.6	27.6	5.4	5.4	5.4	5.13	22.6	22.6	22.6	10.5
13	27.0	27.0	27.0	5.4	5.4	5.4	5.02	22.0	22.0	22.0	10.5
12	26.5	26.5	26.5	5.4	5.4	5.4	4.90	21.4	21.4	21.4	10.5
11	25.9	25.9	25.9	5.4	5.4	5.4	4.79	20.8	20.8	20.8	10.5
10	25.3	25.3	25.3	5.4	5.4	5.4	4.68	20.3	20.3	20.3	10.5
9	24.8	24.8	24.8	5.4	5.4	5.4	4.57	19.7	19.7	19.7	10.5
8	24.2	24.2	24.2	5.4	5.4	5.4	4.47	19.2	19.2	19.2	10.5
7	23.7	23.7	23.7	5.4	5.4	5.4	4.37	18.6	18.6	18.6	10.5
6	23.2	23.2	23.2	5.4	5.4	5.4	4.27	18.1	18.1	18.1	10.5
5	22.7	22.7	22.7	5.4	5.4	5.4	4.17	17.6	17.6	17.6	10.5
4	22.2	22.2	22.2	5.4	5.4	5.4	4.07	17.1	17.1	17.1	10.5
3	21.7	21.7	21.7	5.4	5.4	5.4	3.98	16.6	16.6	16.6	10.5
2	21.2	21.2	21.2	5.4	5.4	5.4	3.89	16.1	16.1	16.1	10.5
1	20.7	20.7	20.7	5.4	5.4	5.4	3.80	15.6	15.6	15.6	10.5
0	20.2	20.2	20.2	5.4	5.4	5.4	3.71	15.1	15.1	15.1	10.5
-1	19.8	19.8	19.8	5.4	5.4	5.4	3.63	14.7	14.7	14.7	10.5
-2	19.3	19.3	19.3	5.4	5.4	5.4	3.54	14.2	14.2	14.2	10.5
-3	18.9	18.9	18.9	5.4	5.4	5.4	3.46	13.8	13.8	13.8	10.5
-4	18.4	18.4	18.4	5.4	5.4	5.4	3.38	13.3	13.3	13.3	10.5
-5	18.0	18.0	18.0	5.4	5.4	5.4	3.31	12.9	12.9	12.9	10.5
-6	17.6	17.6	17.6	5.4	5.4	5.4	3.23	12.5	12.5	12.5	10.5
-7	17.2	17.2	17.2	5.4	5.4	5.4	3.16	12.1	12.1	12.1	10.5
-8	16.7	16.7	16.7	5.4	5.4	5.4	3.09	11.7	11.7	11.7	10.5
-9	16.3	16.3	16.3	5.4	5.4	5.4	3.02	11.3	11.3	11.3	10.5
-10	15.9	15.9	15.9	5.4	5.4	5.4	2.95	10.9	10.9	10.9	10.5
-11	15.6	15.6	15.6	5.4	5.4	5.4	2.88	10.5	10.5	10.5	10.5
-12	15.2	15.2	15.2	5.4	5.4	5.4	2.82	10.1	10.1	10.1	10.5
-13	14.8	14.8	14.8	5.4	5.4	5.4	2.75	9.8	9.8	9.8	10.5
-14	14.4	14.4	14.4	5.4	5.4	5.4	2.69	9.4	9.4	9.4	10.4
-15	14.1	14.1	14.1	5.3	5.3	5.3	2.63	9.1	9.1	9.1	10.4

-- Achtung: Betriebsgrenzen beachten - nicht in Tabelle festgehalten

Tws -VL		55										
	[°C]	Qh nom	Qh min	Qh max	Pin nom	Pin min	Pin max	COP nom	Qc nom	Qc min	Qc max	I nom
Twq -RL	[°C]	[kW]	[kW]	[kW]	[kW]	[kW]	[kW]	kW / kW	[kW]	[kW]	[kW]	[A]
25	34.7	34.7	34.7	7.0	7.0	7.0	4.96	28.1	28.1	28.1	12.3	
24	34.0	34.0	34.0	7.0	7.0	7.0	4.85	27.5	27.5	27.5	12.3	
23	33.3	33.3	33.3	7.0	7.0	7.0	4.75	26.8	26.8	26.8	12.3	
22	32.7	32.7	32.7	7.0	7.0	7.0	4.65	26.1	26.1	26.1	12.3	
21	32.0	32.0	32.0	7.0	7.0	7.0	4.55	25.5	25.5	25.5	12.3	
20	31.4	31.4	31.4	7.1	7.1	7.1	4.46	24.8	24.8	24.8	12.3	
19	30.8	30.8	30.8	7.1	7.1	7.1	4.36	24.2	24.2	24.2	12.3	
18	30.2	30.2	30.2	7.1	7.1	7.1	4.27	23.6	23.6	23.6	12.4	
17	29.6	29.6	29.6	7.1	7.1	7.1	4.18	23.0	23.0	23.0	12.4	
16	29.0	29.0	29.0	7.1	7.1	7.1	4.09	22.4	22.4	22.4	12.4	
15	28.4	28.4	28.4	7.1	7.1	7.1	4.01	21.8	21.8	21.8	12.4	
14	27.8	27.8	27.8	7.1	7.1	7.1	3.92	21.2	21.2	21.2	12.4	
13	27.3	27.3	27.3	7.1	7.1	7.1	3.84	20.6	20.6	20.6	12.4	
12	26.7	26.7	26.7	7.1	7.1	7.1	3.76	20.1	20.1	20.1	12.4	
11	26.2	26.2	26.2	7.1	7.1	7.1	3.68	19.5	19.5	19.5	12.4	
10	25.6	25.6	25.6	7.1	7.1	7.1	3.60	19.0	19.0	19.0	12.4	
9	25.1	25.1	25.1	7.1	7.1	7.1	3.53	18.5	18.5	18.5	12.4	
8	24.6	24.6	24.6	7.1	7.1	7.1	3.45	18.0	18.0	18.0	12.4	
7	24.1	24.1	24.1	7.1	7.1	7.1	3.38	17.4	17.4	17.4	12.4	
6	23.6	23.6	23.6	7.1	7.1	7.1	3.31	16.9	16.9	16.9	12.4	
5	23.1	23.1	23.1	7.1	7.1	7.1	3.24	16.4	16.4	16.4	12.4	
4	22.6	22.6	22.6	7.1	7.1	7.1	3.18	16.0	16.0	16.0	12.4	
3	22.1	22.1	22.1	7.1	7.1	7.1	3.11	15.5	15.5	15.5	12.4	
2	21.7	21.7	21.7	7.1	7.1	7.1	3.05	15.0	15.0	15.0	12.4	
1	21.2	21.2	21.2	7.1	7.1	7.1	2.99	14.6	14.6	14.6	12.4	
0	20.7	20.7	20.7	7.1	7.1	7.1	2.92	14.1	14.1	14.1	12.4	
-1	20.3	20.3	20.3	7.1	7.1	7.1	2.86	13.7	13.7	13.7	12.4	
-2	19.9	19.9	19.9	7.1	7.1	7.1	2.81	13.2	13.2	13.2	12.4	
-3	19.4	19.4	19.4	7.1	7.1	7.1	2.75	12.8	12.8	12.8	12.3	
-4	19.0	19.0	19.0	7.1	7.1	7.1	2.69	12.4	12.4	12.4	12.3	
-5	18.6	18.6	18.6	7.0	7.0	7.0	2.64	12.0	12.0	12.0	12.3	
-6	18.2	18.2	18.2	7.0	7.0	7.0	2.59	11.6	11.6	11.6	12.3	
-7	17.7	17.7	17.7	7.0	7.0	7.0	2.53	11.2	11.2	11.2	12.3	
-8	17.3	17.3	17.3	7.0	7.0	7.0	2.48	10.8	10.8	10.8	12.3	
-9	16.9	16.9	16.9	7.0	7.0	7.0	2.43	10.4	10.4	10.4	12.2	
-10	16.5	16.5	16.5	6.9	6.9	6.9	2.39	10.1	10.1	10.1	12.2	
-11	16.2	16.2	16.2	6.9	6.9	6.9	2.34	9.7	9.7	9.7	12.2	
-12	15.8	15.8	15.8	6.9	6.9	6.9	2.29	9.3	9.3	9.3	12.1	
-13	15.4	15.4	15.4	6.9	6.9	6.9	2.25	9.0	9.0	9.0	12.1	
-14	15.0	15.0	15.0	6.8	6.8	6.8	2.20	8.6	8.6	8.6	12.1	
-15	14.7	14.7	14.7	6.8	6.8	6.8	2.16	8.3	8.3	8.3	12.0	

-- Achtung: Betriebsgrenzen beachten - nicht in Tabelle festgehalten

Tws -VL	65 (T-max)										
	Qh nom	Qh min	Qh max	Pin nom	Pin min	Pin max	COP nom	Qc nom	Qc min	Qc max	I nom
[°C]	[kW]	[kW]	[kW]	[kW]	[kW]	[kW]	kW / kW	[kW]	[kW]	[kW]	[A]
25	34.8	34.8	34.8	9.2	9.2	9.2	3.78	26.2	26.2	26.2	15.0
24	34.2	34.2	34.2	9.2	9.2	9.2	3.71	25.6	25.6	25.6	15.1
23	33.5	33.5	33.5	9.2	9.2	9.2	3.63	24.9	24.9	24.9	15.1
22	32.9	32.9	32.9	9.2	9.2	9.2	3.56	24.3	24.3	24.3	15.1
21	32.3	32.3	32.3	9.2	9.2	9.2	3.50	23.7	23.7	23.7	15.1
20	31.7	31.7	31.7	9.3	9.3	9.3	3.43	23.1	23.1	23.1	15.1
19	31.1	31.1	31.1	9.3	9.3	9.3	3.36	22.5	22.5	22.5	15.1
18	30.6	30.6	30.6	9.3	9.3	9.3	3.30	21.9	21.9	21.9	15.1
17	30.0	30.0	30.0	9.3	9.3	9.3	3.24	21.3	21.3	21.3	15.1
16	29.4	29.4	29.4	9.3	9.3	9.3	3.17	20.8	20.8	20.8	15.1
15	28.9	28.9	28.9	9.3	9.3	9.3	3.11	20.2	20.2	20.2	15.1
14	28.3	28.3	28.3	9.3	9.3	9.3	3.06	19.7	19.7	19.7	15.1
13	27.8	27.8	27.8	9.3	9.3	9.3	3.00	19.1	19.1	19.1	15.1
12	27.3	27.3	27.3	9.3	9.3	9.3	2.94	18.6	18.6	18.6	15.1
11	26.8	26.8	26.8	9.3	9.3	9.3	2.89	18.1	18.1	18.1	15.1
10	26.3	26.3	26.3	9.3	9.3	9.3	2.83	17.6	17.6	17.6	15.1
9	25.8	25.8	25.8	9.3	9.3	9.3	2.78	17.1	17.1	17.1	15.1
8	25.3	25.3	25.3	9.2	9.2	9.2	2.73	16.6	16.6	16.6	15.1
7	24.8	24.8	24.8	9.2	9.2	9.2	2.68	16.1	16.1	16.1	15.1
6	24.3	24.3	24.3	9.2	9.2	9.2	2.63	15.7	15.7	15.7	15.1
5	23.8	23.8	23.8	9.2	9.2	9.2	2.58	15.2	15.2	15.2	15.1
4	23.3	23.3	23.3	9.2	9.2	9.2	2.54	14.7	14.7	14.7	15.0
3	22.9	22.9	22.9	9.2	9.2	9.2	2.49	14.3	14.3	14.3	15.0
2	22.4	22.4	22.4	9.2	9.2	9.2	2.45	13.9	13.9	13.9	15.0
1	22.0	22.0	22.0	9.2	9.2	9.2	2.40	13.4	13.4	13.4	15.0
0	21.5	21.5	21.5	9.1	9.1	9.1	2.36	13.0	13.0	13.0	14.9
-1	21.1	21.1	21.1	9.1	9.1	9.1	2.32	12.6	12.6	12.6	14.9
-2	20.7	20.7	20.7	9.1	9.1	9.1	2.27	12.2	12.2	12.2	14.9
-3	20.2	20.2	20.2	9.1	9.1	9.1	2.23	11.8	11.8	11.8	14.9
-4	19.8	19.8	19.8	9.0	9.0	9.0	2.19	11.4	11.4	11.4	14.8
-5	19.4	19.4	19.4	9.0	9.0	9.0	2.16	11.0	11.0	11.0	14.8
-6	19.0	19.0	19.0	9.0	9.0	9.0	2.12	10.6	10.6	10.6	14.7
-7	18.6	18.6	18.6	8.9	8.9	8.9	2.08	10.2	10.2	10.2	14.7
-8	18.2	18.2	18.2	8.9	8.9	8.9	2.04	9.9	9.9	9.9	14.7
-9	17.8	17.8	17.8	8.8	8.8	8.8	2.01	9.5	9.5	9.5	14.6
-10	17.4	17.4	17.4	8.8	8.8	8.8	1.97	9.1	9.1	9.1	14.6
-11	17.0	17.0	17.0	8.8	8.8	8.8	1.94	8.8	8.8	8.8	14.5
-12	16.6	16.6	16.6	8.7	8.7	8.7	1.90	8.5	8.5	8.5	14.5
-13	16.2	16.2	16.2	8.7	8.7	8.7	1.87	8.1	8.1	8.1	14.4
-14	15.8	15.8	15.8	8.6	8.6	8.6	1.84	7.8	7.8	7.8	14.3
-15	15.5	15.5	15.5	8.6	8.6	8.6	1.81	7.5	7.5	7.5	14.3

-- Achtung: Betriebsgrenzen beachten - nicht in Tabelle festgehalten

Tk -VL	W 12 / 7 °C										
[°C]	Qc nom [kW]	Qc min [kW]	Qc max [kW]	Pin nom [kW]	Pin min [kW]	Pin max [kW]	EER kW / kW	Qh nom [kW]	Qh min [kW]	Qh max [kW]	I nom [A]
40	14.4	14.4	14.4	5.9	5.9	5.9	2.42	19.9	19.9	19.9	11.1
39	14.5	14.5	14.5	5.8	5.8	5.8	2.49	19.9	19.9	19.9	10.9
38	14.5	14.5	14.5	5.7	5.7	5.7	2.57	19.8	19.8	19.8	10.7
37	14.6	14.6	14.6	5.5	5.5	5.5	2.65	19.8	19.8	19.8	10.6
36	14.7	14.7	14.7	5.4	5.4	5.4	2.73	19.7	19.7	19.7	10.5
35	14.8	14.8	14.8	5.2	5.2	5.2	2.82	19.7	19.7	19.7	10.3
34	14.9	14.9	14.9	5.1	5.1	5.1	2.91	19.7	19.7	19.7	10.2
33	15.0	15.0	15.0	5.0	5.0	5.0	2.99	19.6	19.6	19.6	10.1
32	15.0	15.0	15.0	4.9	4.9	4.9	3.08	19.6	19.6	19.6	9.9
31	15.1	15.1	15.1	4.8	4.8	4.8	3.18	19.6	19.6	19.6	9.8
30	15.2	15.2	15.2	4.6	4.6	4.6	3.27	19.5	19.5	19.5	9.7
29	15.3	15.3	15.3	4.5	4.5	4.5	3.37	19.5	19.5	19.5	9.6
28	15.4	15.4	15.4	4.4	4.4	4.4	3.46	19.5	19.5	19.5	9.5
27	15.4	15.4	15.4	4.3	4.3	4.3	3.56	19.5	19.5	19.5	9.4
26	15.5	15.5	15.5	4.2	4.2	4.2	3.67	19.5	19.5	19.5	9.3
25	15.6	15.6	15.6	4.1	4.1	4.1	3.77	19.4	19.4	19.4	9.2
24	15.6	15.6	15.6	4.0	4.0	4.0	3.87	19.4	19.4	19.4	9.1
23	15.7	15.7	15.7	3.9	3.9	3.9	3.98	19.4	19.4	19.4	9.0
22	15.8	15.8	15.8	3.9	3.9	3.9	4.09	19.4	19.4	19.4	8.9
21	15.8	15.8	15.8	3.8	3.8	3.8	4.20	19.4	19.4	19.4	8.9
20	15.9	15.9	15.9	3.7	3.7	3.7	4.31	19.4	19.4	19.4	8.8

Tc [°C]	W 23 / 18 °C										
[°C]	Qc nom [kW]	Qc min [kW]	Qc max [kW]	Pin nom [kW]	Pin min [kW]	Pin max [kW]	EER kW / kW	Qh nom [kW]	Qh min [kW]	Qh max [kW]	I nom [A]
40	19.3	19.3	19.3	5.9	5.9	5.9	3.25	24.9	24.9	25.3	11.0
39	19.4	19.4	19.4	5.8	5.8	5.8	3.35	24.8	24.8	25.2	10.9
38	19.6	19.6	19.6	5.7	5.7	5.7	3.46	24.8	24.8	25.2	10.7
37	19.7	19.7	19.7	5.5	5.5	5.5	3.56	24.8	24.8	25.1	10.6
36	19.8	19.8	19.8	5.4	5.4	5.4	3.67	24.8	24.8	25.1	10.4
35	19.9	19.9	19.9	5.2	5.2	5.2	3.79	24.7	24.7	25.0	10.3
34	20.0	20.0	20.0	5.1	5.1	5.1	3.90	24.7	24.7	25.0	10.1
33	20.1	20.1	20.1	5.0	5.0	5.0	4.02	24.7	24.7	25.0	10.0
32	20.2	20.2	20.2	4.9	4.9	4.9	4.14	24.7	24.7	24.9	9.9
31	20.3	20.3	20.3	4.8	4.8	4.8	4.26	24.7	24.7	24.9	9.8
30	20.4	20.4	20.4	4.6	4.6	4.6	4.39	24.7	24.7	24.9	9.7
29	20.5	20.5	20.5	4.5	4.5	4.5	4.52	24.7	24.7	24.8	9.6
28	20.6	20.6	20.6	4.4	4.4	4.4	4.65	24.7	24.7	24.8	9.5
27	20.7	20.7	20.7	4.3	4.3	4.3	4.78	24.7	24.7	24.8	9.4
26	20.8	20.8	20.8	4.2	4.2	4.2	4.91	24.7	24.7	24.8	9.3
25	20.9	20.9	20.9	4.1	4.1	4.1	5.05	24.7	24.7	24.7	9.2
24	21.0	21.0	21.0	4.0	4.0	4.0	5.19	24.7	24.7	24.7	9.1
23	21.1	21.1	21.1	3.9	3.9	3.9	5.33	24.7	24.7	24.7	9.0
22	21.1	21.1	21.1	3.9	3.9	3.9	5.48	24.7	24.7	24.7	8.9
21	21.2	21.2	21.2	3.8	3.8	3.8	5.62	24.7	24.7	24.7	8.9
20	21.3	21.3	21.3	3.7	3.7	3.7	5.77	24.7	24.7	24.7	8.8

-- Achtung: Betriebsgrenzen beachten - nicht in Tabelle festgehalten

LEGENDE:

T_{wq-RL}: Temperatur Wärmequelle - Eintritt [°C]

T_{ws-VL}: Temperatur Wärmesenke - Vorlauf [°C]

T_{k-VL}: Temperatur Kältesenke - Vorlauf [°C]

Q_{h nom}: Heizleistung nominal

Q_{h min}: Heizleistung minimal

Q_{h max}: Heizleistung maximal

P_{in nom}: Aufnahme bei nominaler Heizleistung

P_{in min}: Aufnahme bei minimaler Heizleistung

P_{in max}: Aufnahme bei maximaler Heizleistung

COP nom: Arbeitszahl bei nominaler Heizleistung

Q_{c nom}: Kälteleistung/Energieentnahme bei nominaler Heizleistung

Q_{c min}: Kälteleistung/Energieentnahme bei minimaler Heizleistung

Q_{c max}: Kälteleistung/Energieentnahme bei maximaler Heizleistung

I nom: Stromaufnahme bei nominaler Heizleistung

EER: Arbeitszahl bei nominaler Kälteleistung

Betriebsgrenzen

Temp °C

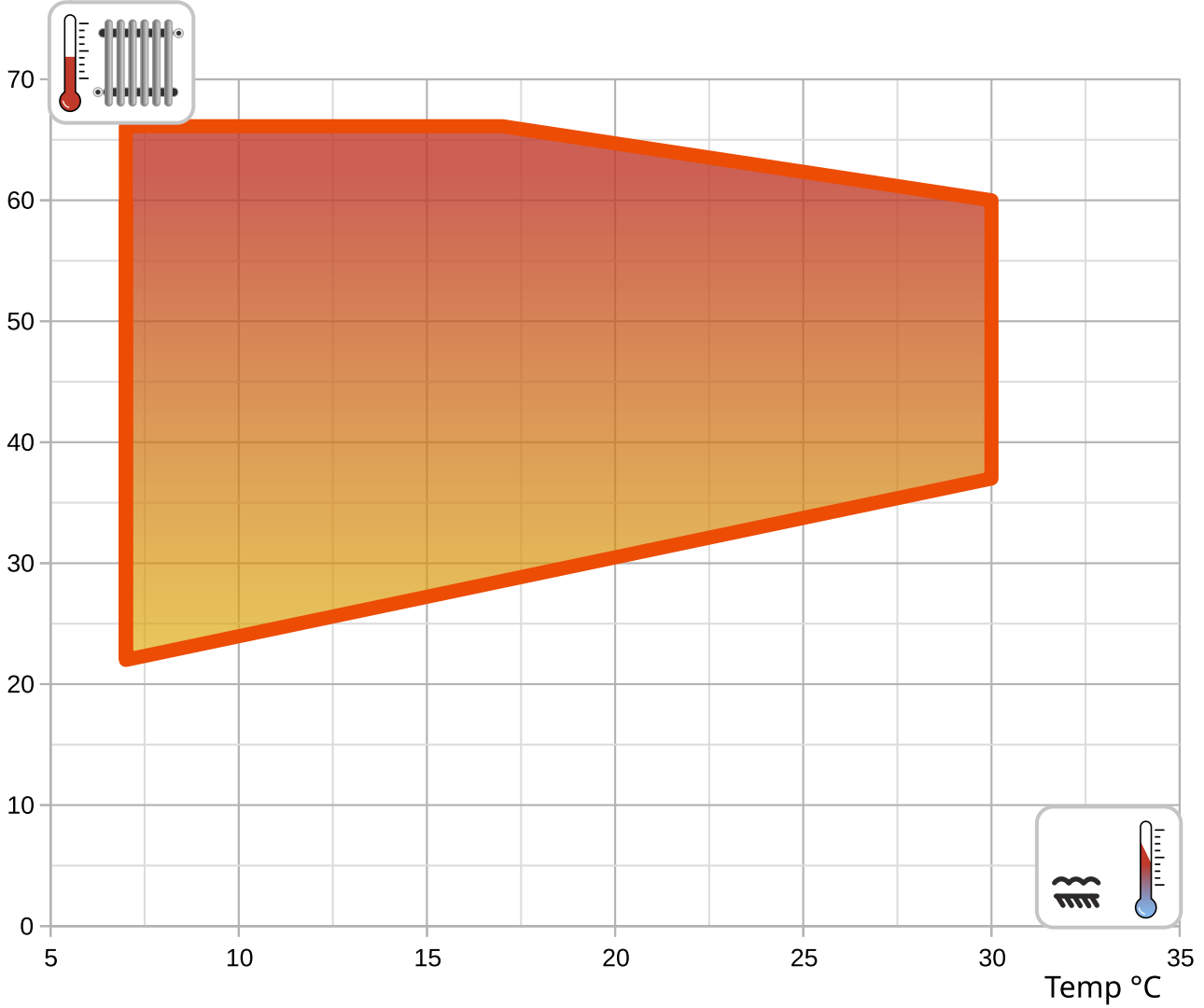

Temp °C

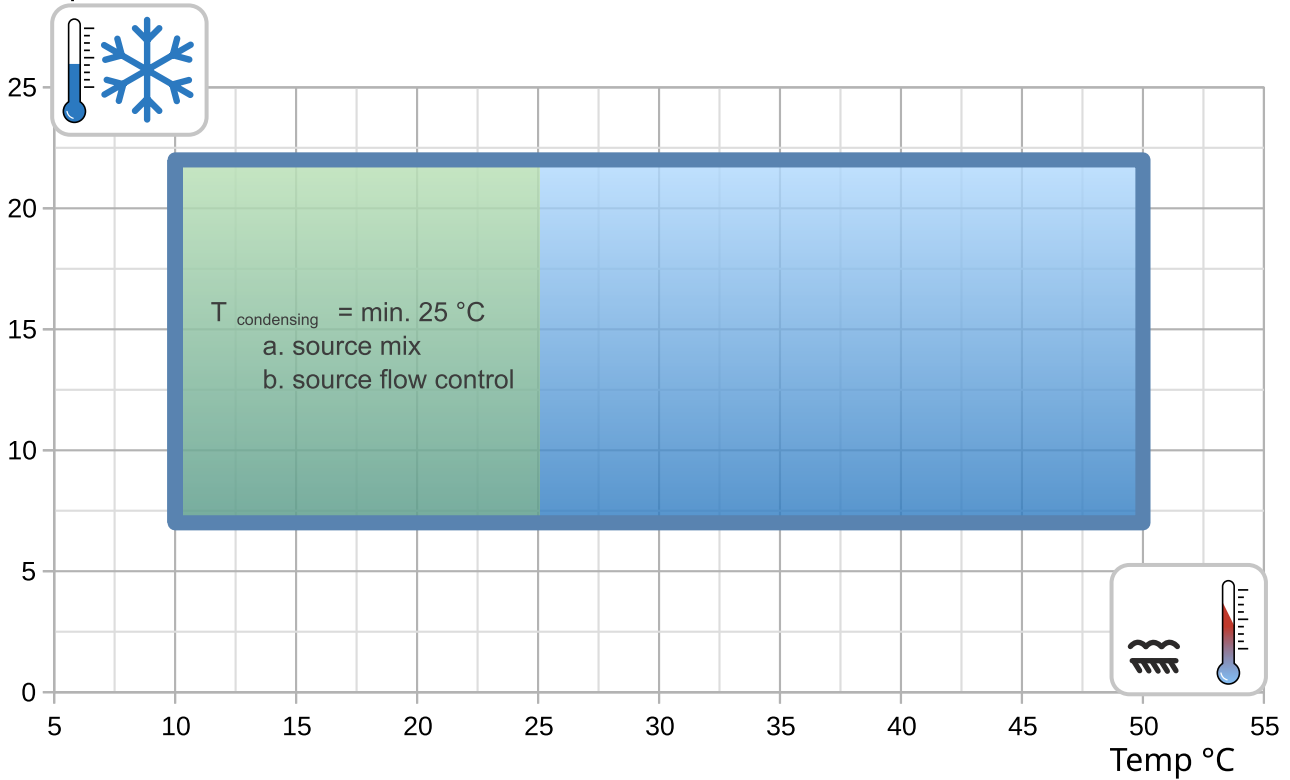

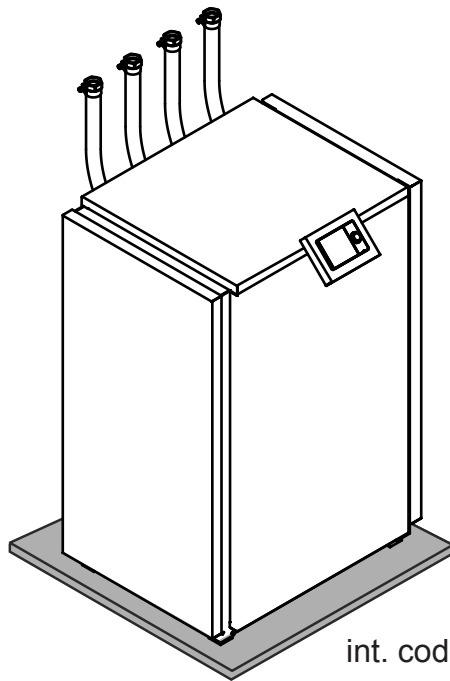
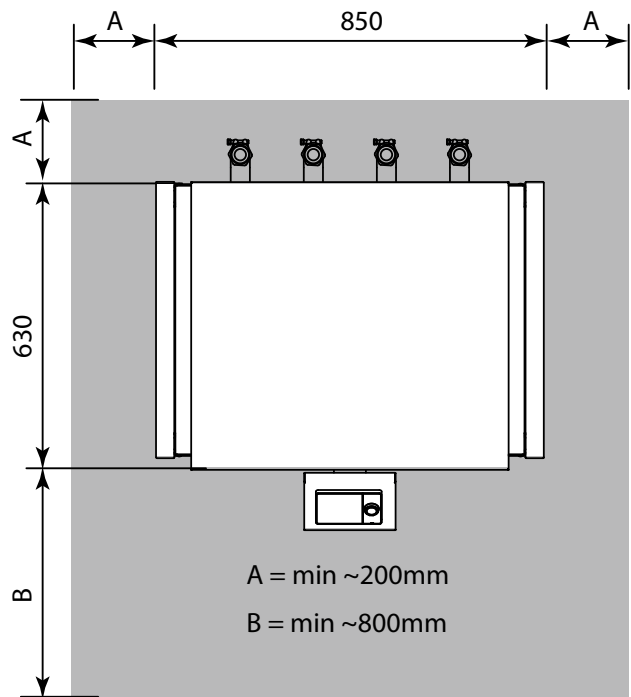
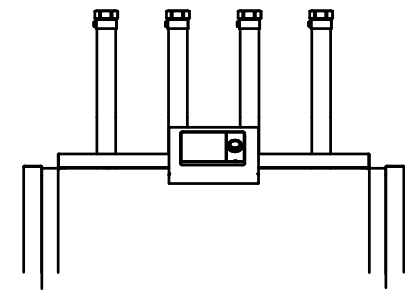
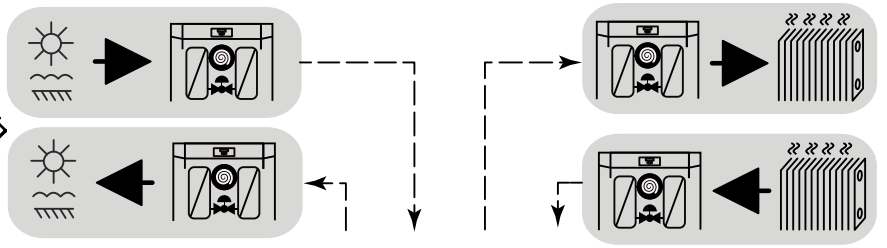
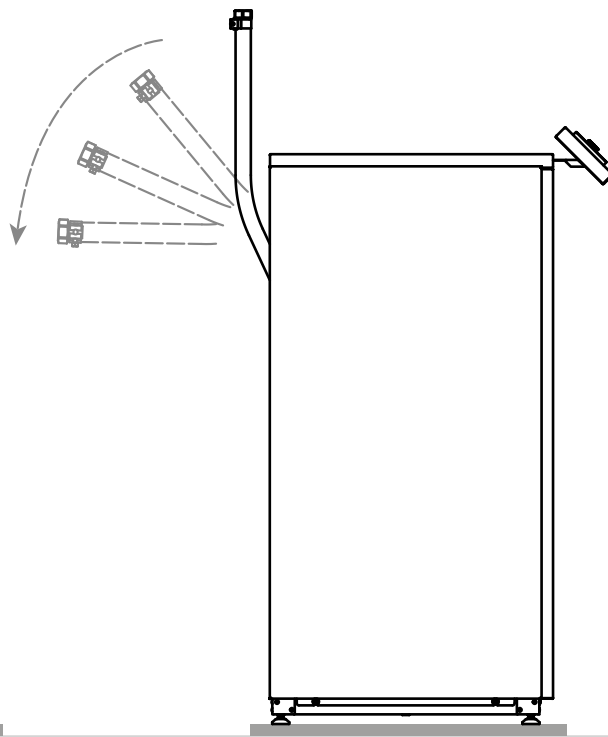
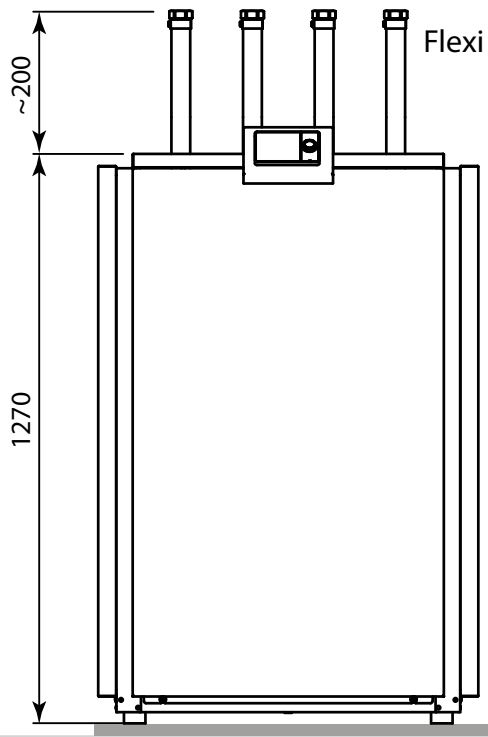

int. code: VN800

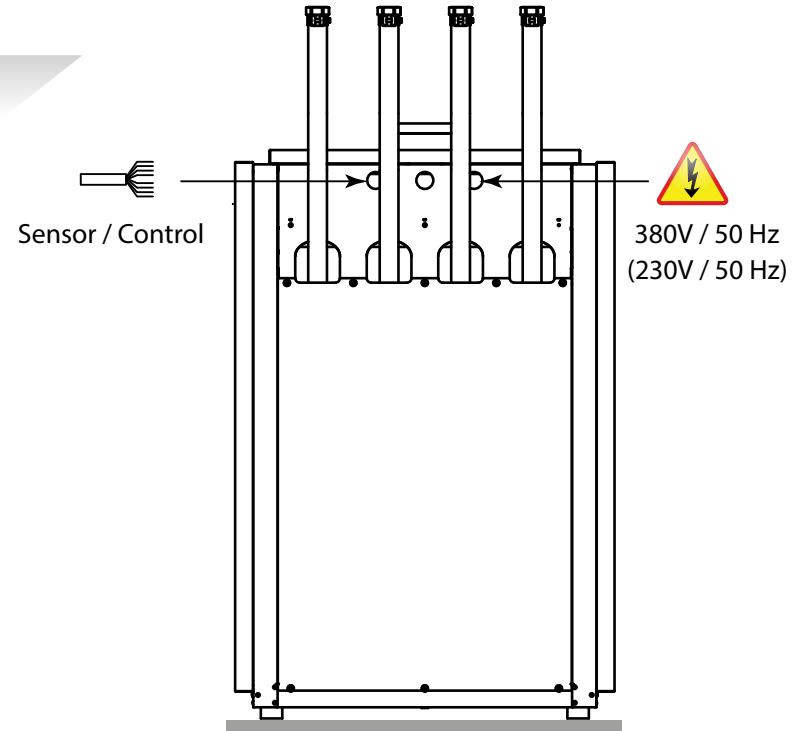

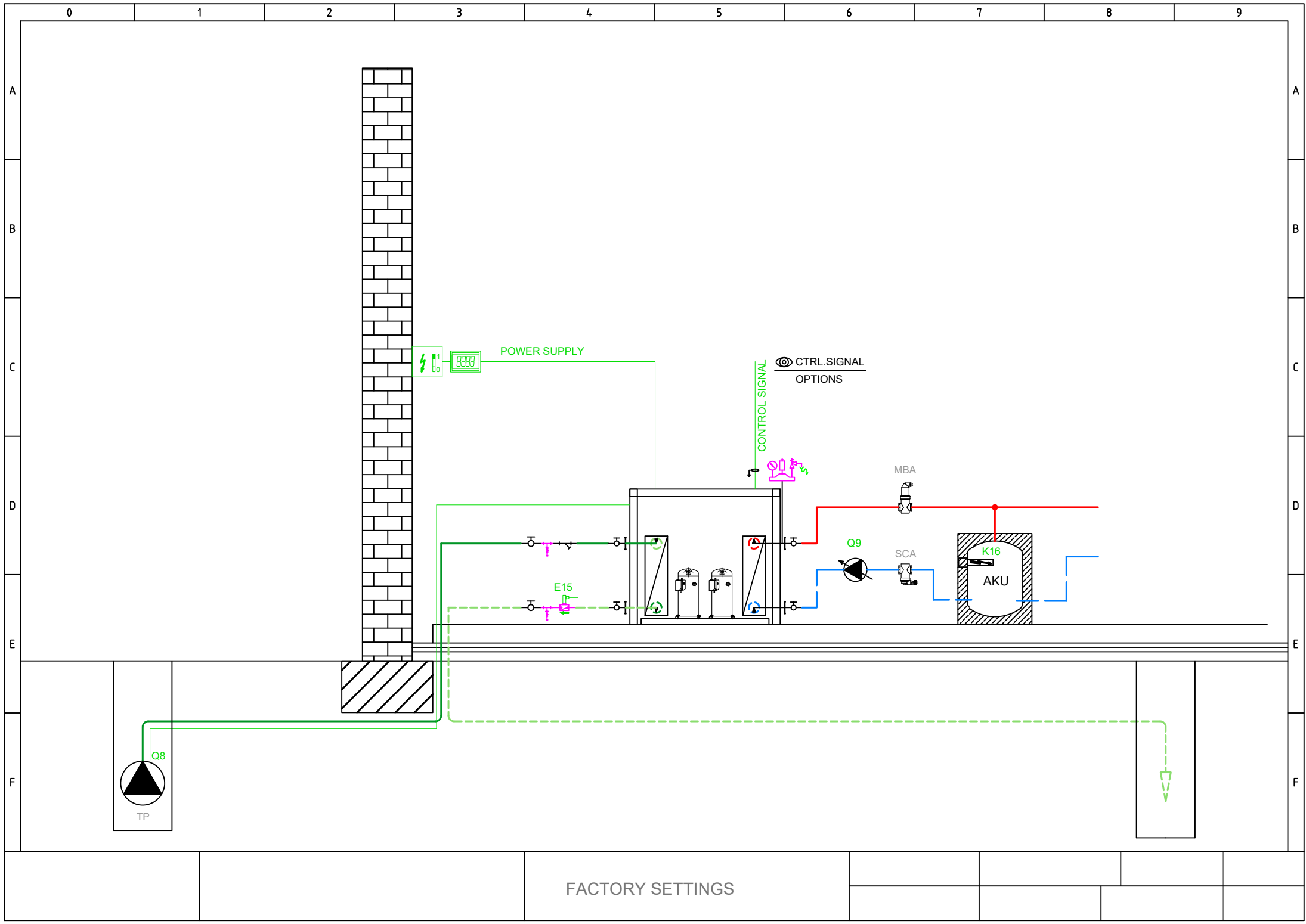

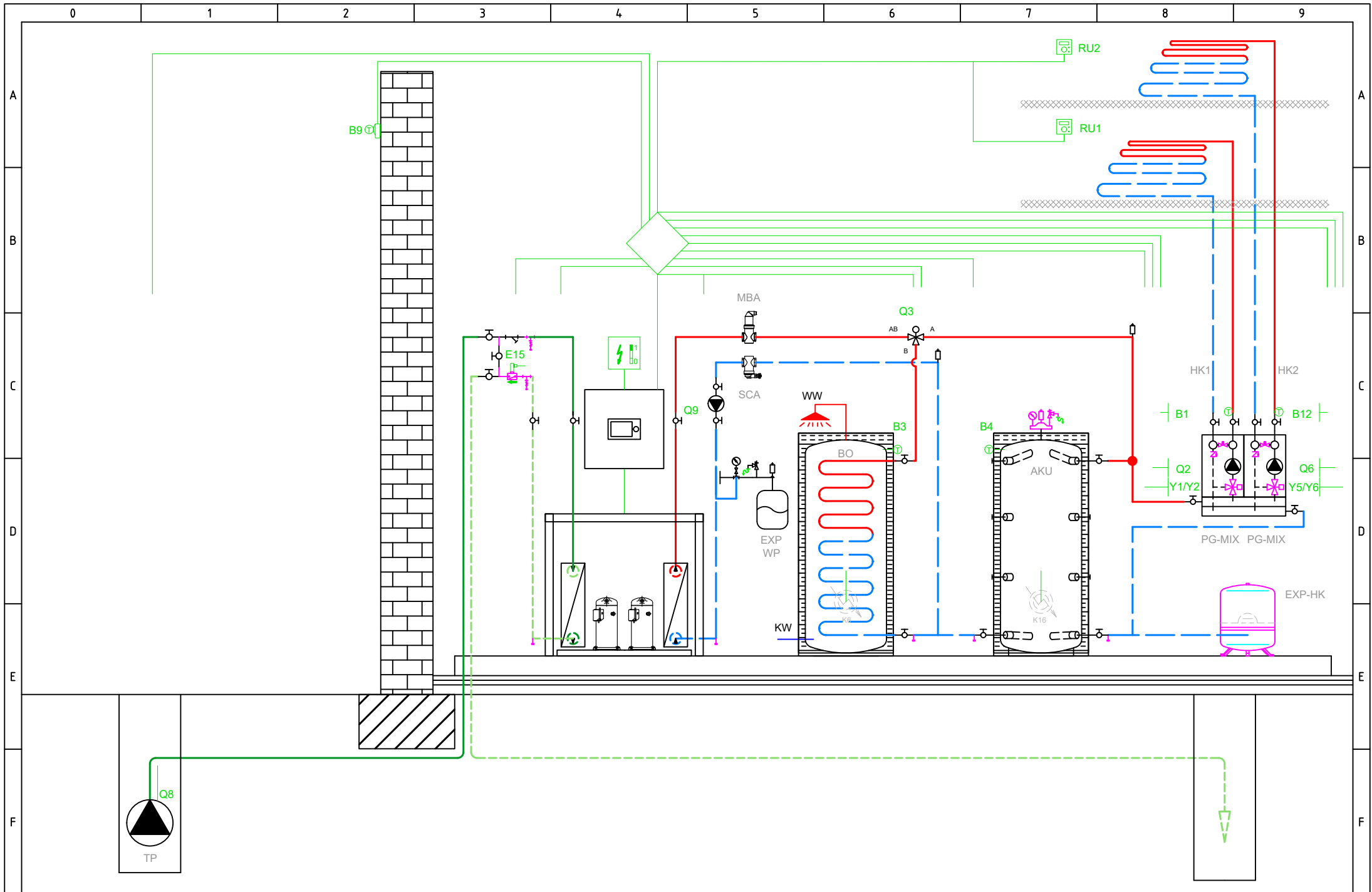

BASIC APPLICATION

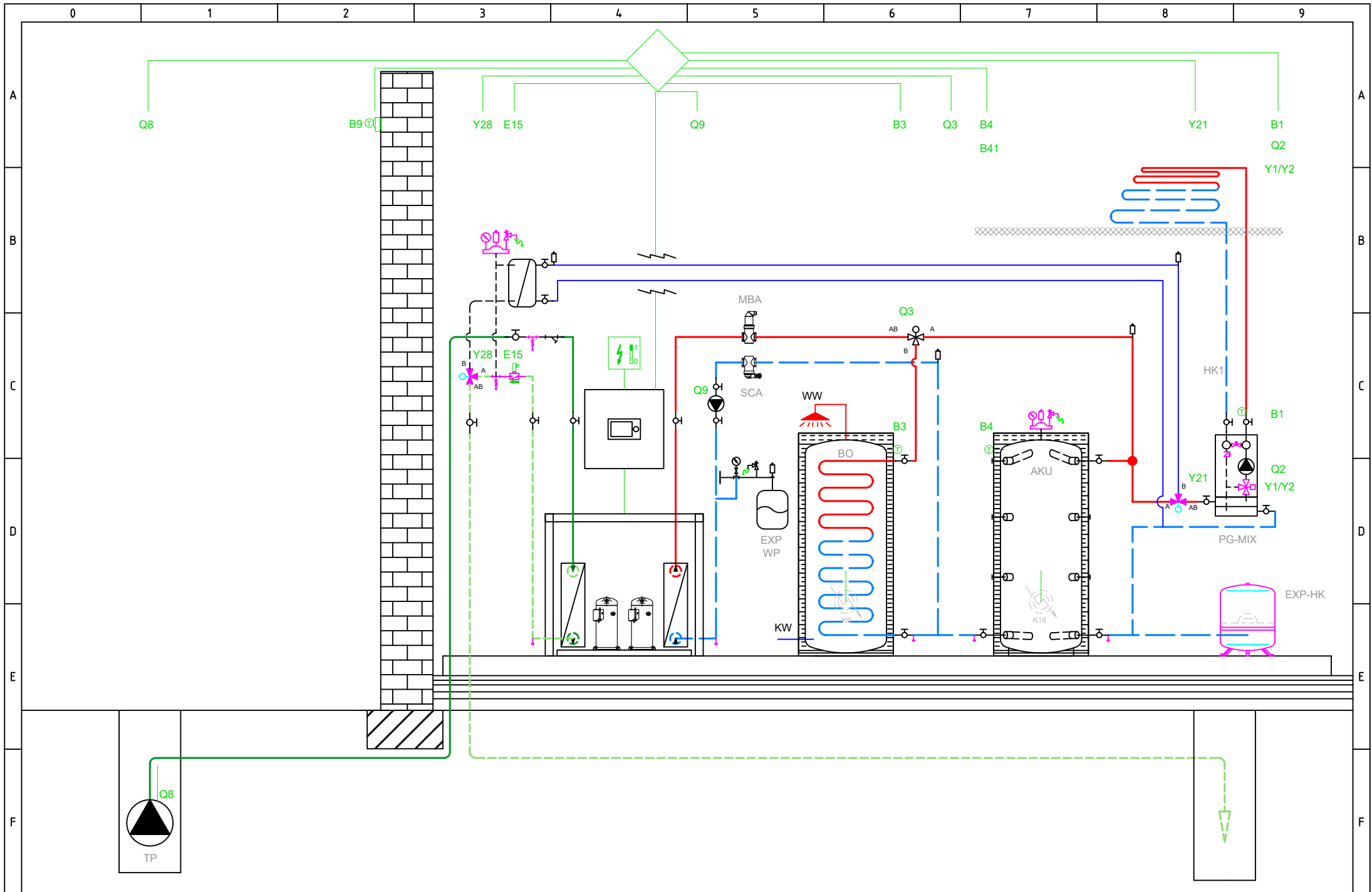

OPTIONAL APPLICATION

Total: max 6A
1 x QX...: max 2A

Netzanschluss 230V / 50 Hz
Erde
Nullleiter

- E9 Niederdruckwächter E9
- E10 Hochdruckwächter E10
- E15 Ström'wächter Quelle E15
- E24 Ström'wächter Verbrau E24
- E6 EW Sperre E6
- E12 Überlast Verdichter 2 E12
- E21 Drehstrom E21
- E22 Drehstrom E22
- E23 Drehstrom E23
- E11 Überlast Verdichter 1 E11
- K1 Verdichterstufe 1 K1

Q8 Quellpumpe Q8

Q9 Kondensatorpumpe Q9

K10 Alarmausgang K10

K40 Ölumpfheizung K40

K81 Ventil Verdampfer K81

K82 Ventil EVI K82

K2 Verdichterstufe 2 K2

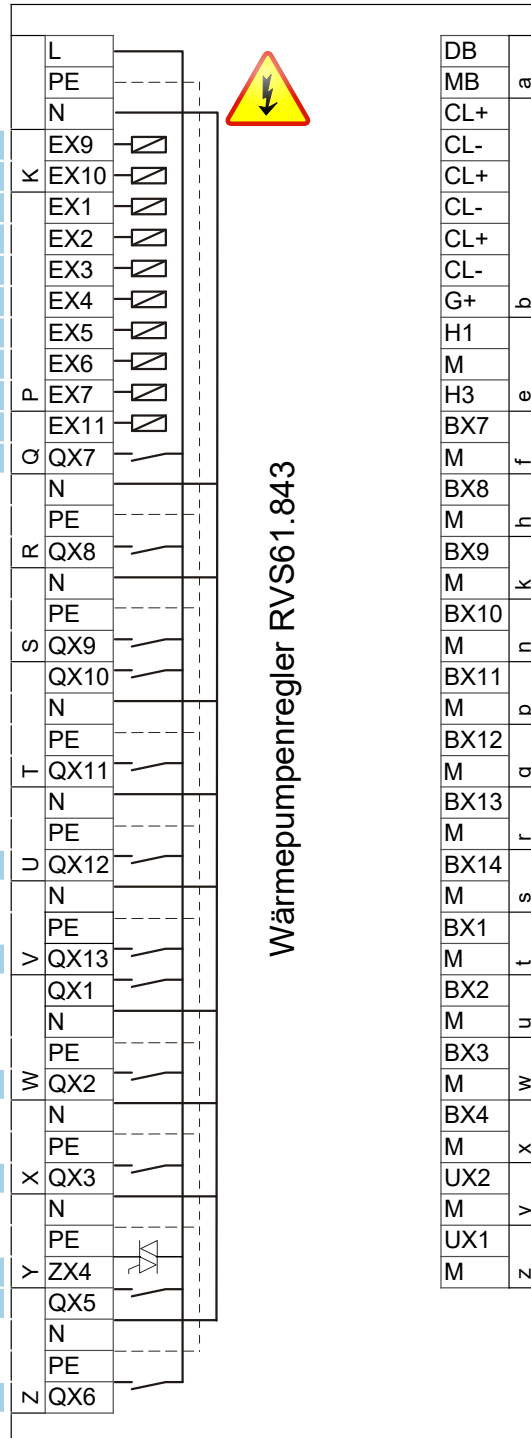

DB		LPB Bus Data
MB	a	LPB Bus Masse
CL+		Raumgerät QAA...
CL-		Raumgerät QAA...
CL+		Raumgerät QAA... 2.
CL-		Raumgerät QAA... 2.
CL+		Raumgerät QAA... 3.
CL-		Raumgerät QAA... 3.
G+	b	12V Versorgung → AUS
H1		
M		
H3	e	Verbr'anforderung VK1
BX7		B81 Heissgasfühler K1 B81
M	f	
BX8		
M	h	
BX9		
M	k	B21 WP Vorlauffühler B21
BX10		
M	n	
BX11		
M	p	B71 WP Rücklauffühler B71
BX12		
M	q	B91 Quelleneintrittfühler B91
BX13		
M	r	B84 Quellenaust'fühler B92/B84
BX14		
M	s	
BX1		
M	t	
BX2		
M	u	B83 Kältemittelfühler flüssig B83
BX3		
M	w	B82 Heissgasfühler K2 B82
BX4		
M	x	Kondensatorpumpe Q9
UX2		0..10V Analogsignal
M	y	Quell'pumpe Q8
UX1		0..10V Analogsignal
M	z	



- AVS75.390
- AVS75.391
- AVS75.370

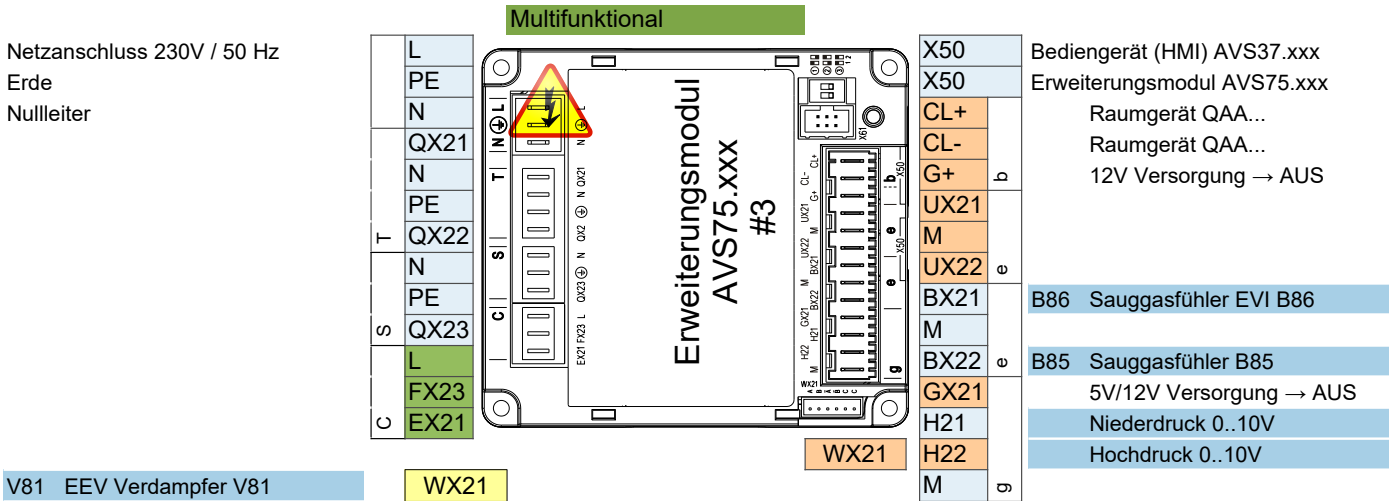
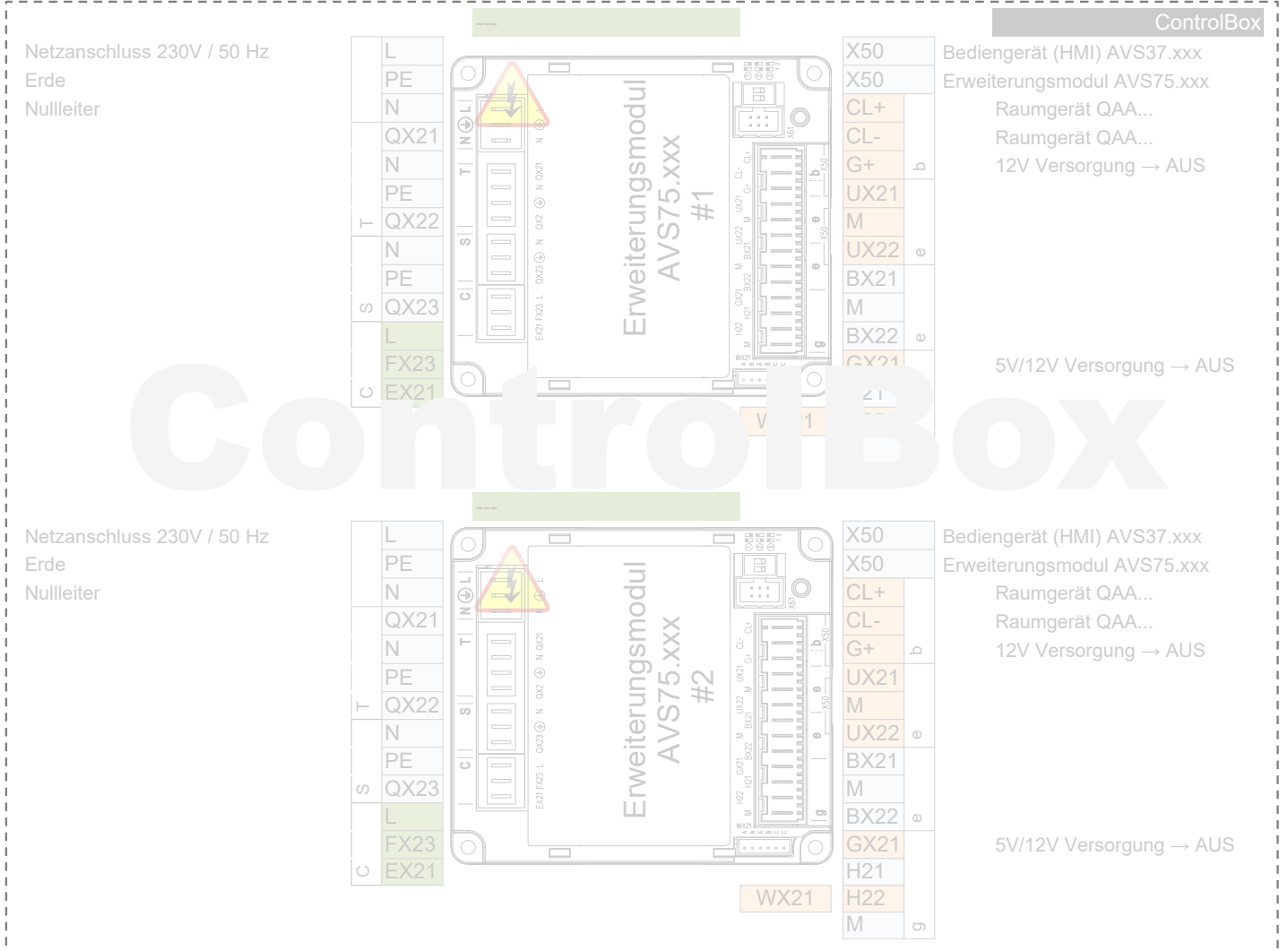

HEAT PUMP

EXTERNAL
INTERNAL

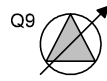
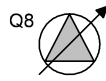

K1

K2

K82

K81

K40

K10

Q8 UX1

Q9 UX2

E11
KRW1
F1K
E11

E12
KRW2
F2K
E12

E6

E24
Q9.ERR
F1S
E24

E15
Q8.ERR
F1Z
E15

E10

E9

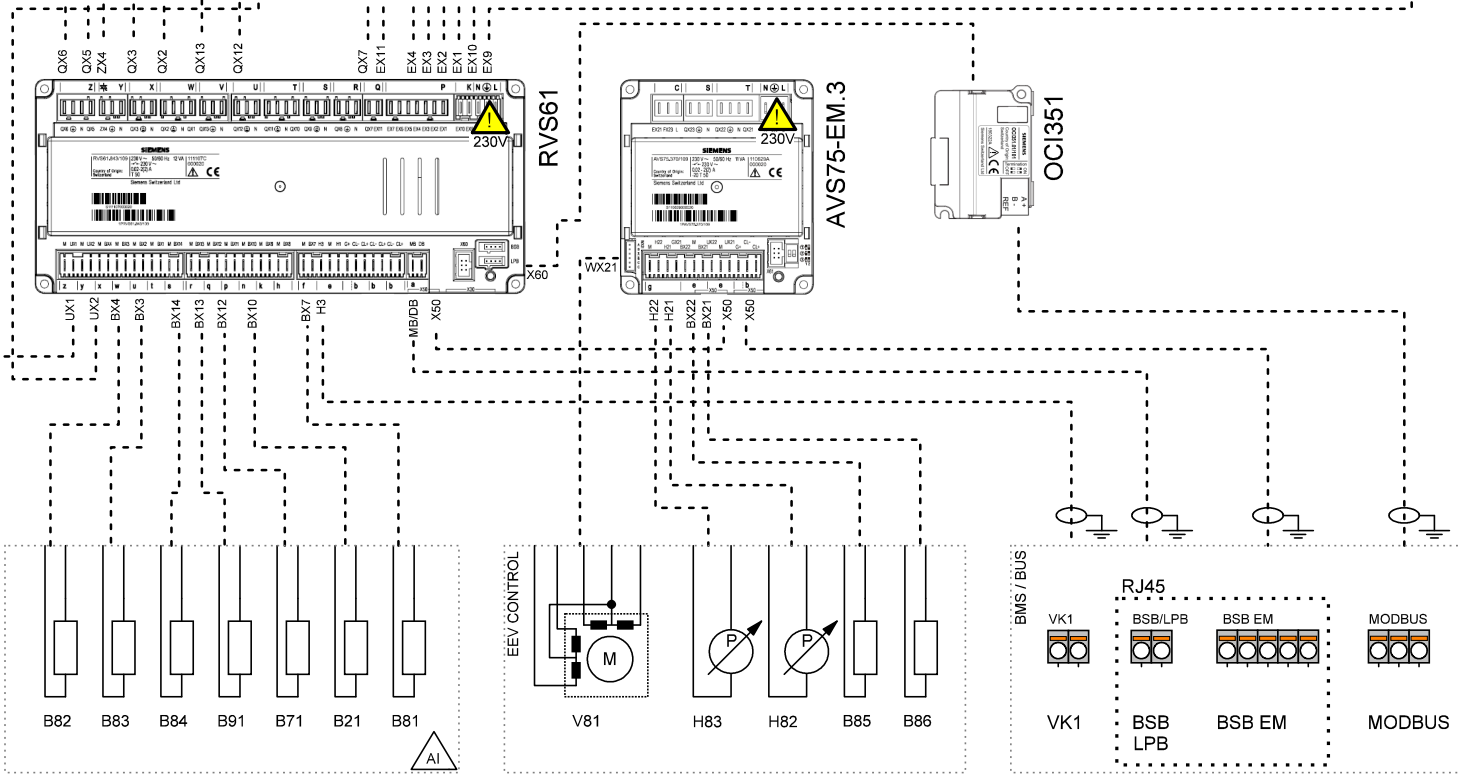
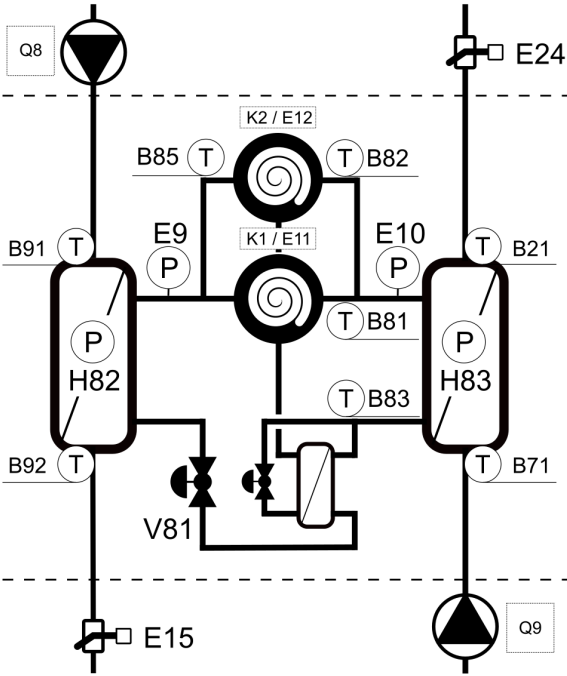
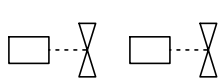

PWR SPLY: 3~ 400V, 50 Hz
CTRL: 1~ 230V, 50 HZ

Company

Title
TBW-TWW

Version / Note
05/2024

Number

Created by

Date

Page
1

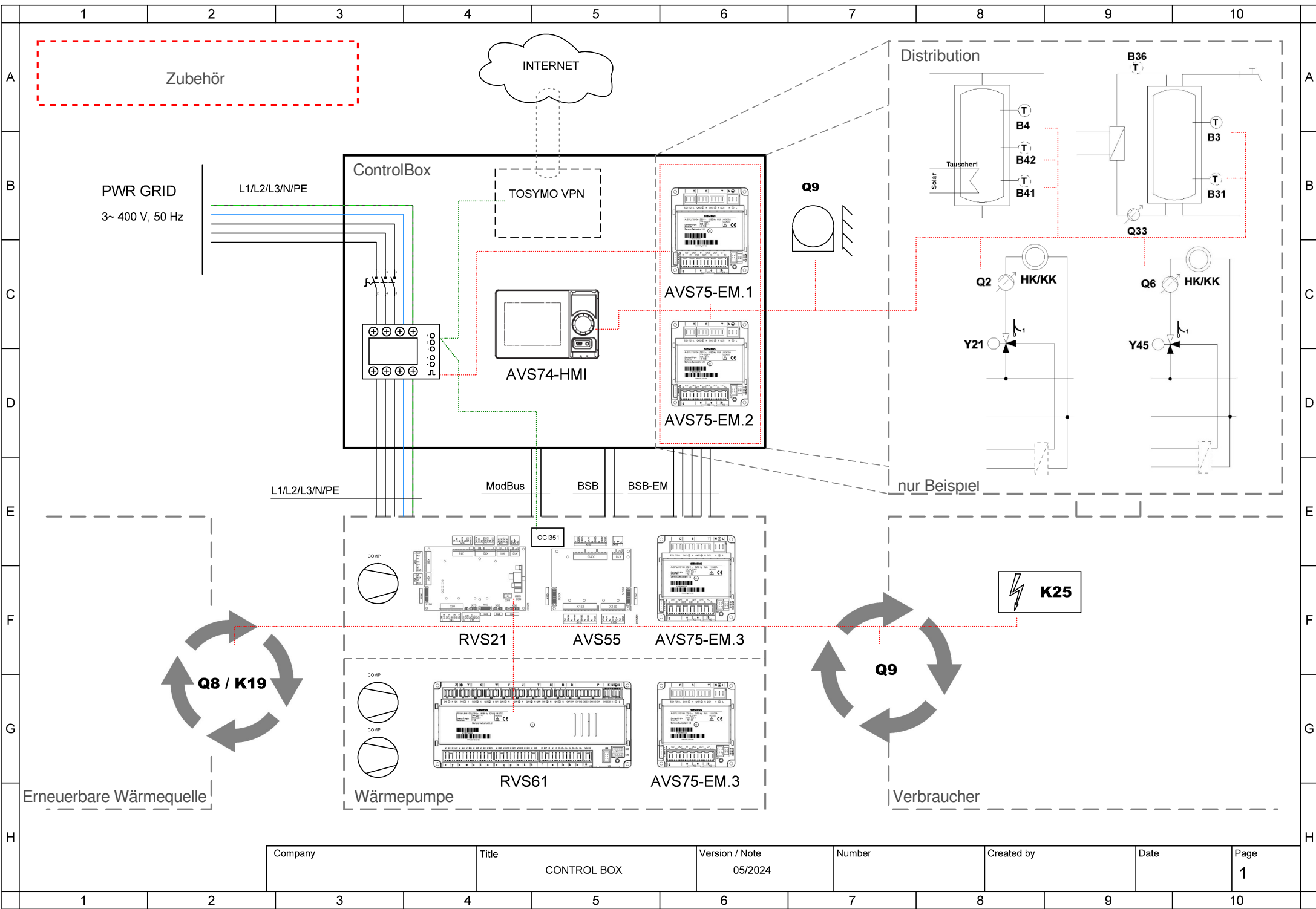

Company	Title	Version / Note	Number	Created by	Date	Page
	CONTROL BOX	05/2024				1



Company	Title CONTROL BOX	Version / Note 05/2024	Number	Created by	Date	Page 2
---------	----------------------	---------------------------	--------	------------	------	-----------



Company	Title	Version / Note	Number	Created by	Date	Page
	CONTROL BOX	05/2024				3



Company	Title	Version / Note	Number	Created by	Date	Page
	CONTROL BOX	05/2024				4



- AVS75.390
- AVS75.391
- AVS75.370

- AVS75.370**
 Netzanschluss 230V / 50 Hz
 Erde
 Nullleiter
Y1 Mischer Auf

Y2 Mischer Zu

Q2 Heizkreispumpe HK1 Q2

L Faze 230V
E61 Smart Grid E61

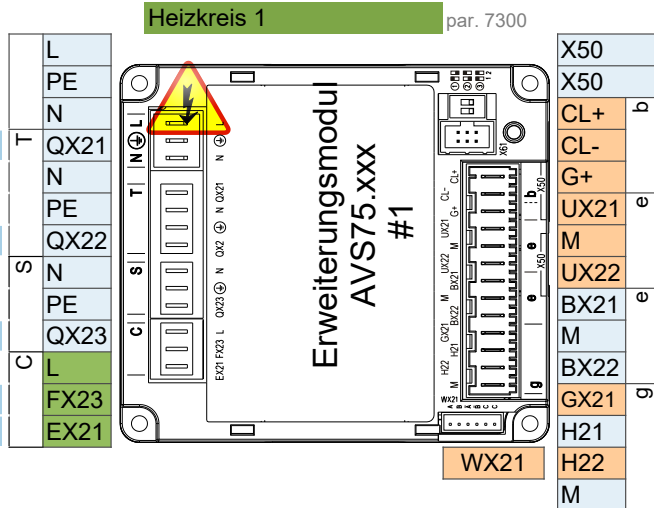

- Erweiterungsmodul AVS75.xxx
 Raumgerät QAA...
 Raumgerät QAA...

B1 Vorlauffühler 1

Impulszählung

- AVS75.370**
 Netzanschluss 230V / 50 Hz
 Erde
 Nullleiter
Q3 Trinkwasserstellglied Q3

K6 Elektroeinsatz TWW K6

Q6 Heizkreispumpe HK2 Q6

L Faze 230V
E62 Smart Grid E62

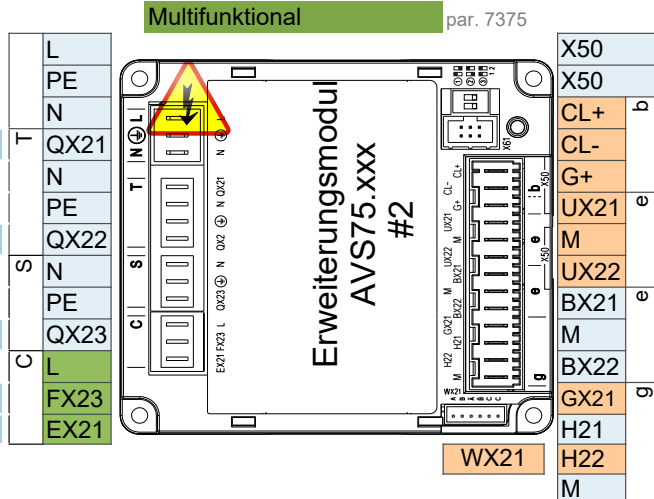

- Bediengerät (HMI) AVS37.xxx
 Erweiterungsmodul AVS75.xxx
 Raumgerät QAA...
 Raumgerät QAA...

B3 Trinkwasserfühler B3

B4 Pufferspeicherfühler B4

- Netzanschluss 230V / 50 Hz
 Erde
 Nullleiter

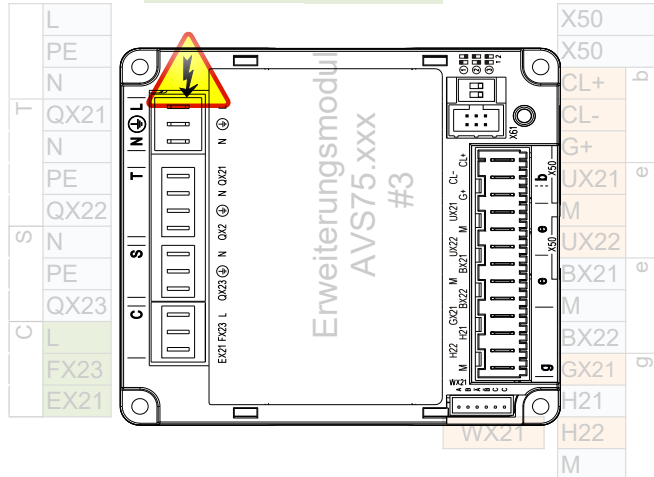

- Bediengerät (HMI) AVS37.xxx
 Erweiterungsmodul AVS75.xxx
 Raumgerät QAA...
 Raumgerät QAA...

Vorsicht: Erweiterungsmodul 3 ist in der Wärmepumpe

Anschlussmöglichkeiten für die Steuerung

1 ControlBox

ControlBox, mit zwei eingebauten Erweiterungsmodulen, ermöglicht zahlreiche Optionen für die Anwendungssteuerung auf der Verbraucherseite hinter der Wärmepumpe. Weitere Informationen finden Sie im Schaltplan der ControlBox und im Blatt mit den Anwendungsdiagrammen.

2 Fixer Sollwert Vorlauftemperatur - Ein / Aus potentialfreier Kontakt

2-adriges abgeschirmtes Kabel 2 x 0,5 mm² - Sollwert = 45°C (editierbar über Parameter 1859)

Anschlussklemme - siehe Schaltplan

3 Analog 0..10V Vorlauftemperatur-Sollwertregelung

2 Adern geschirmtes Kabel 2 x 0,5 mm² - Sollwert: 0V = 16°C ~ 10V = 60°C (editierbar im Parametersatz)

Anschlussklemme - siehe Schaltplan

4 ModBus RTU-Kommunikationsbefehl

3-adriges abgeschirmtes Kabel min. 3 x 0,25mm²

Für die ModBus-Zuordnungstabelle wenden Sie sich bitte an den technischen Support

5 MQTT IoT-Kommunikationsprotokoll

Für weitere Informationen wenden Sie sich bitte an den technischen Support