

Basic performance data - WAMAK BW 14 EVI

Heating - EN 14511		
Heating capacity [kW]	B0 / W35 (max)	14.5
	B0 / W35 (min)	14.5
	B0 / W34	14.4
Electrical power input [kW]	B0 / W35 (max)	3.1
	B0 / W35 (min)	3.1
	B0 / W34	3.0
Heating efficiency faktor [COP]	B0 / W35 (max)	4.63
	B0 / W35 (min)	4.63
	B0 / W34	4.74
Seasonal space heating energy efficiency - SCOP EN 14825		
Average Climate / Low Temperature [35 °C]	SCOP	5.29
	η [%]	211.4
	Label	A+++
	Qhe [kWh]	5627.5
	Pdesignh [kW]	14.5
	Tbivalent [°C]	-10
Cooling		
Cooling capacity - [kW]	A35 / W23-18	14.8
	A25 / W23-18	15.8
	A35 / W12-7	14.8
	A25 / W12-7	14.8
Seasonal space cooling energy efficiency - SEER EN 14825		
[W 23 / 18 °C]	SEER	5.58
	Qce [kWh]	1479.7
	η_c [%]	223.3
Sound EN 12102		
Acoustic power - Lw	dB(A)	45.2
Acoustic pressure - Lp	1 m dB(A)	37.2
	5 m dB(A)	23.2
	10 m dB(A)	17.2
Mechanical and operational information		
Compressor type (3~ 400/50)	SCROLL / 1 /	On/Off
Refrigerant	R410A (GWP - 2088)	2.4 kg
Operating limit temperatures heating - (min / max) [°C]		25 / 65
Operating limit temperatures source - (min / max) [°C]		-10 (7) / 30
Weight		155 kg

Main technical data - WAMAK BW 14 EVI

Enclosure type			VN600			Heat energy rejection side data			
Basic dimensions	Height [mm]	1270	Operating limit temperatures heating	MAX [°C]	65	for more see operating limits diagram	Condenser	Port size	1.1/4 "
	Width [mm]	650		MIN [°C]	25			Type	BPHE
	Length [mm]	630		Count	1			Material	AISI 316
Weight [kg]	155		Maximal operating pressure - refrigerant [bar]	45		Heat transfer medium	Volume flow @ dT 5K (nom) - Water [m3/h]	2.50	
Colour	Gray		Maximal operating pressure - Water [bar]	6			Internal pressure drop - Water [kPa]	12	
Enclosure IP Class	IP20		Testing pressure [bar]	70			ECM speed circulator - condenser	UPM3 25-75	
Refrigeration cycle			Heat transfer medium	Water		Flow sensor consumer - analogue	0..10V		
Compressor	Type	Scroll	Volume flow @ dT 5K (nom) - Water [m3/h]	2.50		Temperature difference @ 35°C (nom)	5 K		
	Number of stages	1	Internal pressure drop - Water [kPa]	12		@ 55°C	8 K		
	On/Off		ECM speed circulator - condenser	UPM3 25-75		@ 65°C	10 K		
	Power factor Cosφ	0.77	Flow sensor consumer - analogue	0..10V		Renewable energy extraction side data			
	Winding resistance	2.33 Ohm	Temperature difference @ 35°C (nom)	5 K		Operating limit temperatures source	MIN [°C]	-10 (7)	
Refrigerant		R410A	Temperature difference @ 55°C	8 K		MAX [°C]	30		
	Volme	2.4 kg	Temperature difference @ 65°C	10 K		for more see operating limits diagram			
	GWP	2088	Maximal operating pressure - refrigerant [bar]	28		Evaporator	Port size	1.1/4 "	
	Safety class	A1	Heat transfer medium	Ethylenglykol		Type	BPHE		
Refrigeration oil type	POE RL32-3MAF		Brine proportion [%]	29		Count	1		
	Oil volume	1.24 L	Antifreeze to [°C]	-15		Material	AISI 316		
Maximal pressure - refrigerant [bar]	45		Maximal operating pressure - Ethylenglykol [bar]	6		Maximal operating pressure - refrigerant [bar]	28		
	PED class	1	Volume flow - Ethylenglykol [m3/h]	3.44		Heat transfer medium	Ethylenglykol		
EVI - vapour injection with economizer			Internal pressure drop - Ethylenglykol [kPa]	12		Brine proportion [%]	29		
Electrical connection data			Temperature difference - Ethylenglykol	3 K		Antifreeze to [°C]	-15		
Line voltage [#~ V/Hz]	3~ 400/50		ECM speed circulator - evaporator	UPMXL GEO 32-125		Control System			
Current	nominal [A]	5.58	Main controller SIEMENS RVS 21 AVS 55.199						
	maximal [A]	10.90	Extension AVS75.391 AVS75.391 AVS75.3xx						
	starting [A]	15.06	Bus Clip-In LPB OCI346 Modbus OCI352						
Softstart	MCI 12		Online connection Web server ToSyMo OZW672						
Main safety	C25		*** with accessory						

WAMAK BW 14 EVI

ErP (EU) No 811/2013: Technical parameters for heat pump space heaters

Model	BW 14 EVI
Air-to-water heat pump	no
Brine-to-water heat pump	yes
Water-to-water heat pump	no
Low-temperature heat pump	no
Equipped with a supplementary heater	no
Heat pump combination heater	no
Temperature application	low (35°C - 30°C)
Climate conditions	average

Item	Symbol	Value	Unit	Item	Symbol	Value	Unit
Rated heat output at Tdesignh	Prated	14.5	kW	Seasonal space heating energy efficiency	η_s	211.4	%
Declared capacity for heating for part load at indoor temperature 20 °C and outdoor temperature Tj				Declared coefficient of performance or primary energy ratio for part load at indoor temperature 20 °C and outdoor temperature Tj			
Tj = -7 °C	Pdh	14.4	kW	Tj = -7 °C	COPd	4.74	-
Tj = +2 °C	Pdh	14.4	kW	Tj = +2 °C	COPd	5.2	-
Tj = +7 °C	Pdh	14.3	kW	Tj = +7 °C	COPd	5.6	-
Tj = +12 °C	Pdh	14.3	kW	Tj = +12 °C	COPd	6.1	-
Tj = bivalent temperature	Pdh	14.5	kW	Tj = bivalent temperature	COPd	4.6	-
Tj = operation limit temperature	Pdh	---	kW	Tj = operation limit temperature	COPd	---	-
Bivalent temperature	Tbiv	-10	°C	Tj = operation limit temperature	TOL	---	°C
Power consumption in modes other than active mode				Heating water operating limit temperature	WTOL	65	°C
Off mode	Poff	0.010	kW	Supplementary heater			
Thermostat-off mode	Pto	0.010	kW	Rated heat output	Psup	2.8	kW
Standby mode	Psb	0.010	kW	Type of energy input	electricity		
Crankcase heater mode	Pck	0.000	kW				
Other items				For air-to-water heat pumps: Rated air flow rate, outdoors	-	---	m ³ /h
Capacity control	fixed			For water- or brine-to-water heat pumps: Rated brine or water flow rate, outdoor heat exchanger	-	3.44	m ³ /h
Sound power level							
indoors	Lwa	45	dB				
outdoors	Lwa	---	dB				
Annual energy consumption	Q _{HE}	5627.5	kWh				

Contact details: WAMAK, s.r.o., Orovnic 252, 96652, Orovnic, Slovakia, info@wamak.sk

WAMAK BW 14 EVI

ErP (EU) No 811/2013: Technical parameters for heat pump space heaters

Model	BW 14 EVI
Air-to-water heat pump	no
Brine-to-water heat pump	yes
Water-to-water heat pump	no
Low-temperature heat pump	no
Equipped with a supplementary heater	no
Heat pump combination heater	no
Temperature application	middle (55°C - 47°C)
Climate conditions	average

Item	Symbol	Value	Unit	Item	Symbol	Value	Unit
Rated heat output at Tdesignh	Prated	14.9	kW	Seasonal space heating energy efficiency	η_s	164.4	%
Declared capacity for heating for part load at indoor temperature 20 °C and outdoor temperature Tj				Declared coefficient of performance or primary energy ratio for part load at indoor temperature 20 °C and outdoor temperature Tj			
Tj = -7 °C	Pdh	14.9	kW	Tj = -7 °C	COPd	3.29	-
Tj = +2 °C	Pdh	14.9	kW	Tj = +2 °C	COPd	4.3	-
Tj = +7 °C	Pdh	14.6	kW	Tj = +7 °C	COPd	4.8	-
Tj = +12 °C	Pdh	14.6	kW	Tj = +12 °C	COPd	5.3	-
Tj = bivalent temperature	Pdh	14.9	kW	Tj = bivalent temperature	COPd	2.9	-
Tj = operation limit temperature	Pdh	---	kW	Tj = operation limit temperature	COPd	---	-
Bivalent temperature	Tbiv	-10	°C	Tj = operation limit temperature	TOL	---	°C
Power consumption in modes other than active mode				Heating water operating limit temperature	WTOL	65	°C
Off mode	Poff	0.010	kW	Supplementary heater			
Thermostat-off mode	Pto	0.010	kW	Rated heat output	Psup	2.8	kW
Standby mode	Psb	0.010	kW	Type of energy input	electricity		
Crankcase heater mode	Pck	0.000	kW	For air-to-water heat pumps:			
Other items				Rated air flow rate, outdoors	-	---	m ³ /h
Capacity control	fixed			For water- or brine-to-water heat pumps: Rated brine or water flow rate, outdoor heat exchanger			
Sound power level							
indoors	Lwa	45	dB				
outdoors	Lwa	---	dB				
Annual energy consumption	Q _{HE}	7448.8	kWh				

Contact details: WAMAK, s.r.o., Orovnicna 252, 96652, Orovnicna, Slovakia, info@wamak.sk



ENERG Y IIA
 енергия - ενεργεια IE IA

WAMAK

BW 14 EVI



55 °C

35 °C



A+++

A+++

45 dB
 --- dB

■ 16	■ 15
■ 15	■ 15
■ 15	■ 14
kW	kW

2019

811/2013

BW 14 EVI

ErP Data

	55 °C	35 °C
Energy class	A+++	A+++
η [%]	164.4	211.4
P_{rated} [kW]	15	15
Q_{HE} [kWh/y]	7449	5628
SCOP [-]	4.11	5.29
$T_{bivalent}$ [°C]	-10	-10

CONTROLLER



+ QAA55/75 class VII 3.5% ↓
 - QAA55/75 class III 1.5% ↓

Heating performance data

Version: v2024.010-BW-WW

Source - Brine [0°C] / Low Temperature [35°C]

ZHI14K1P-TFM_R410A_1_BWW

Operating conditions	Qh	P	COP
1 B0 / W30-35	14.5	3.1	4.63
2 B0 / W30-35 (MIN)	14.5	3.1	4.63
A B0 / Wxx-34	14.4	3.0	4.74
B B0 / Wxx-30	14.4	2.7	5.24
C B0 / Wxx-27	14.3	2.5	5.65
D B0 / Wxx-24	14.3	2.3	6.09
E B0 / Wxx-35	14.5	3.1	4.63
F B0 / Wxx-35	14.5	3.1	4.63

SCOP DATA EN 14825:2018	
Source - Brine [0°C] / Low Temperature [35°C]	
SCOPon	5.32
SCOPnet	5.32
SCOP	5.29
η [%]	211.45
Label	A+++
Qh [kWh]	5627
Pdesignh [kW]	14.5
Tbivalent [°C]	-10

Source - Brine [0°C] / Medium Temperature [55°C]

Operating conditions	Qh	P	COP
1 B0 / W47-55	14.9	5.2	2.88
2 B0 / W47-55 (MIN)	14.9	5.0	2.88
A B0 / Wxx-52	14.9	4.7	3.29
B B0 / Wxx-42	14.9	3.5	4.25
C B0 / Wxx-36	14.6	3.1	4.75
D B0 / Wxx-30	14.6	2.7	5.31
E B0 / Wxx-55	14.9	5.2	2.88
F B0 / Wxx-54	14.9	4.8	3.12

SCOP DATA EN 14825:2018	
Source - Brine [0°C] / Medium Temperature [55°C]	
SCOPon	4.13
SCOPnet	4.13
SCOP	4.11
η [%]	164.43
Label	A+++
Qh [kWh]	7449
Pdesignh [kW]	14.9
Tbivalent [°C]	-10

Source - Water [10°C] / Low Temperature [35°C]

Operating conditions	Qh	P	COP
1 W10 / W30-35	18.4	3.0	6.08
2 W10 / W30-35 (MIN)	18.4	3.0	6.08
A W10 / Wxx-34	18.4	2.9	6.25
B W10 / Wxx-30	18.5	2.6	6.99
C W10 / Wxx-27	18.5	2.4	7.60
D W10 / Wxx-24	18.5	2.2	8.26
E W10 / Wxx-35	18.4	3.0	6.08
F W10 / Wxx-35	18.4	3.0	6.08

SCOP DATA EN 14825:2018	
Source - Water [10°C] / Low Temperature [35°C]	
SCOPon	7.11
SCOPnet	7.11
SCOP	7.06
η [%]	282.51
Label	A+++
Qh [kWh]	5343
Pdesignh [kW]	18.4
Tbivalent [°C]	-10.00

Source - Water [10°C] / Medium Temperature [55°C]

	Operating conditions	Qh	P	COP
1	W10 / W47-55	18.3	5.1	3.55
2	W10 / W47-55 (MIN)	18.3	5.1	3.55
A	W10 / Wxx-52	18.5	4.6	3.99
B	W10 / Wxx-42	18.6	3.5	5.37
C	W10 / Wxx-36	18.6	3.0	6.26
D	W10 / Wxx-30	18.7	2.6	7.09
E	W10 / Wxx-55	18.3	5.1	3.55
F	W10 / Wxx-55	18.3	5.1	3.55

SCOP DATA EN 14825:2018	
Source - Water [10°C] / Medium Temperature [55°C]	
SCOPon	5.20
SCOPnet	5.20
SCOP	5.18
η [%]	207.03
Label	A+++
Qh [kWh]	7265
Pdesignh [kW]	18.3
Tbivalent [°C]	-10.00

Low temperature cooling W 12 / 7°C

	Operating conditions	Qc	P	EER
A	W30-35 / W12-7	11.4	3.4	3.37
B	W26-xx / W12-7	11.6	3.0	3.81
C	W22-xx / W12-7	11.8	2.7	4.30
D	W18-xx / W12-7	11.9	2.6	4.57

SEER DATA EN 14825:2018 [W 12 / 7°C]	
SEERon	4.15
SEER	4.13
Qc [kWh]	6600
η [%]	165.35

Radiant cooling W 23 / 18°C

	Operating conditions	Qc	P	EER
A	W50-xx / W23-18	13.1	5.6	2.36
B	W40-xx / W23-18	14.3	4.3	3.29
C	W30-35 / W23-18	15.3	3.4	4.54
D	W26-xx / W23-18	15.7	3.0	5.14

SEER DATA EN 14825:2018 [W 23 / 18°C]	
SEERon	5.61
SEER	5.58
Qc [kWh]	6600
η [%]	223.30

Performance lines - heating

- Qh-nom-35 — Qh-min-35 - - - Qh-max-65 — Qh-nom-45 — Qh-nom-55
- Qh-nom-65

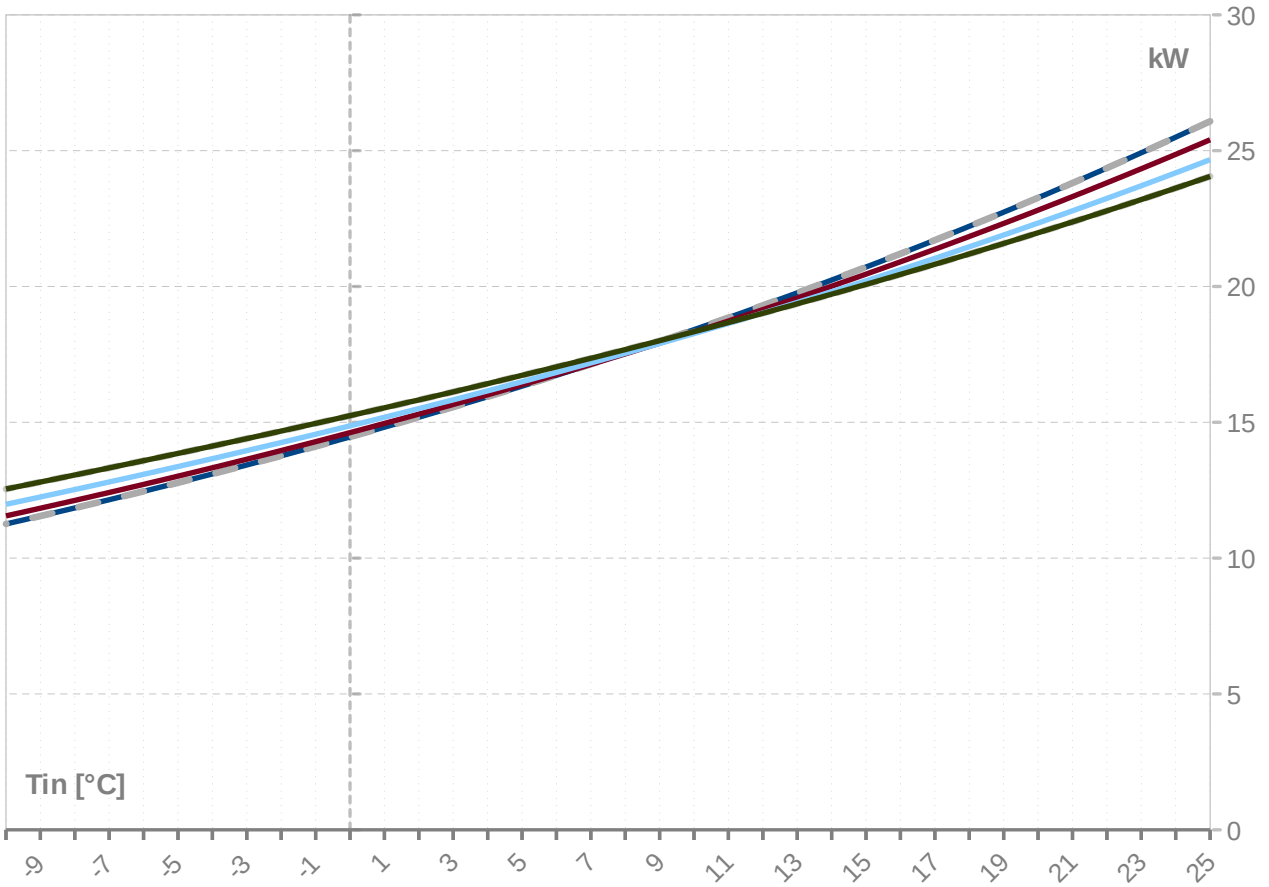

Performance lines - cooling

- Qc-nom-12-7 — Qc-nom-23-18

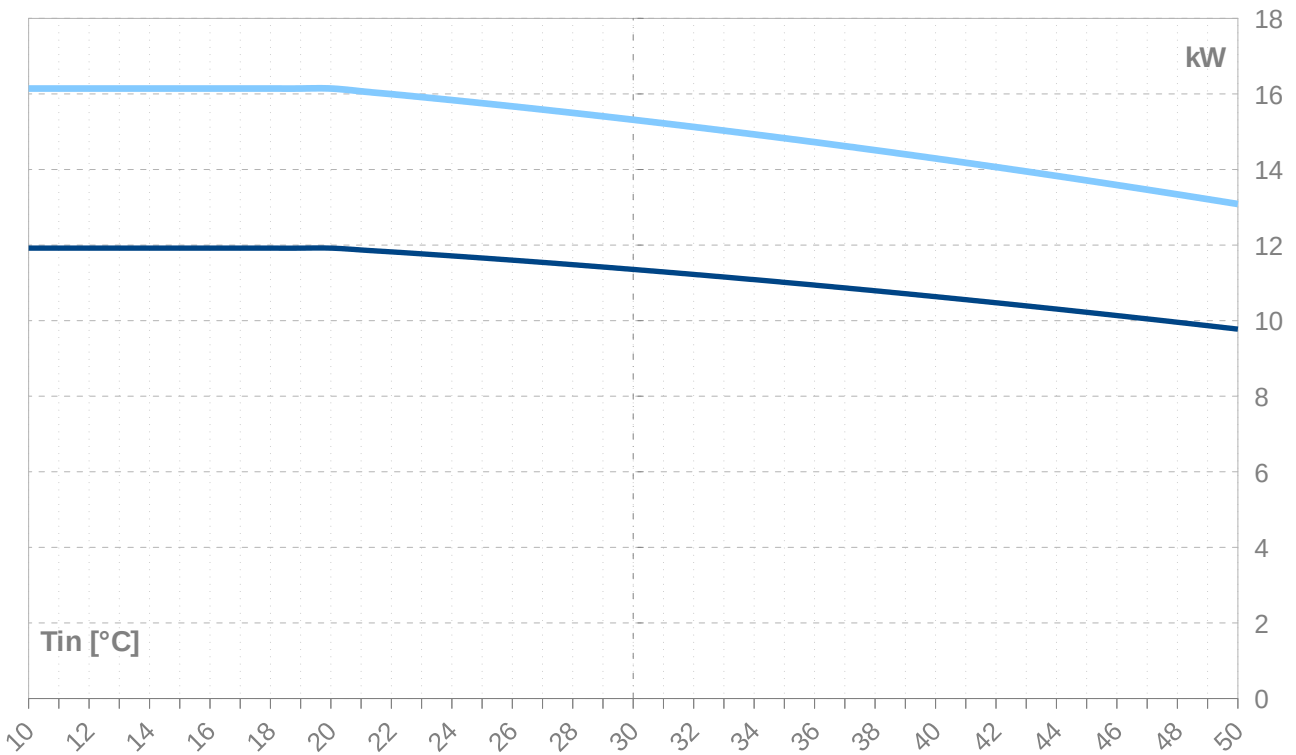

Th -OU	35										
Ts -IN [°C]	Qh nom [kW]	Qh min [kW]	Qh max [kW]	Pin nom [kW]	Pin min [kW]	Pin max [kW]	COP nom kW / kW	Qc nom [kW]	Qc min [kW]	Qc max [kW]	I nom [A]
25	26.1	26.1	26.1	2.8	2.8	2.8	9.28	23.5	23.5	23.5	5.3
24	25.5	25.5	25.5	2.8	2.8	2.8	9.02	22.9	22.9	22.9	5.3
23	24.9	24.9	24.9	2.8	2.8	2.8	8.77	22.3	22.3	22.3	5.3
22	24.4	24.4	24.4	2.9	2.9	2.9	8.53	21.7	21.7	21.7	5.3
21	23.8	23.8	23.8	2.9	2.9	2.9	8.29	21.1	21.1	21.1	5.4
20	23.3	23.3	23.3	2.9	2.9	2.9	8.06	20.6	20.6	20.6	5.4
19	22.7	22.7	22.7	2.9	2.9	2.9	7.84	20.0	20.0	20.0	5.4
18	22.2	22.2	22.2	2.9	2.9	2.9	7.62	19.5	19.5	19.5	5.4
17	21.7	21.7	21.7	2.9	2.9	2.9	7.41	19.0	19.0	19.0	5.4
16	21.2	21.2	21.2	2.9	2.9	2.9	7.20	18.5	18.5	18.5	5.4
15	20.7	20.7	20.7	3.0	3.0	3.0	7.00	18.0	18.0	18.0	5.5
14	20.2	20.2	20.2	3.0	3.0	3.0	6.81	17.5	17.5	17.5	5.5
13	19.8	19.8	19.8	3.0	3.0	3.0	6.62	17.0	17.0	17.0	5.5
12	19.3	19.3	19.3	3.0	3.0	3.0	6.43	16.5	16.5	16.5	5.5
11	18.9	18.9	18.9	3.0	3.0	3.0	6.26	16.0	16.0	16.0	5.5
10	18.4	18.4	18.4	3.0	3.0	3.0	6.08	15.6	15.6	15.6	5.5
9	18.0	18.0	18.0	3.0	3.0	3.0	5.92	15.1	15.1	15.1	5.6
8	17.6	17.6	17.6	3.1	3.1	3.1	5.75	14.7	14.7	14.7	5.6
7	17.1	17.1	17.1	3.1	3.1	3.1	5.60	14.3	14.3	14.3	5.6
6	16.7	16.7	16.7	3.1	3.1	3.1	5.44	13.9	13.9	13.9	5.6
5	16.3	16.3	16.3	3.1	3.1	3.1	5.30	13.5	13.5	13.5	5.6
4	15.9	15.9	15.9	3.1	3.1	3.1	5.15	13.1	13.1	13.1	5.6
3	15.6	15.6	15.6	3.1	3.1	3.1	5.02	12.7	12.7	12.7	5.6
2	15.2	15.2	15.2	3.1	3.1	3.1	4.88	12.3	12.3	12.3	5.6
1	14.8	14.8	14.8	3.1	3.1	3.1	4.75	11.9	11.9	11.9	5.7
0	14.5	14.5	14.5	3.1	3.1	3.1	4.63	11.5	11.5	11.5	5.7
-1	14.1	14.1	14.1	3.1	3.1	3.1	4.51	11.2	11.2	11.2	5.7
-2	13.8	13.8	13.8	3.1	3.1	3.1	4.39	10.8	10.8	10.8	5.7
-3	13.4	13.4	13.4	3.1	3.1	3.1	4.27	10.5	10.5	10.5	5.7
-4	13.1	13.1	13.1	3.1	3.1	3.1	4.16	10.2	10.2	10.2	5.7
-5	12.8	12.8	12.8	3.1	3.1	3.1	4.06	9.8	9.8	9.8	5.7
-6	12.5	12.5	12.5	3.1	3.1	3.1	3.96	9.5	9.5	9.5	5.7
-7	12.1	12.1	12.1	3.1	3.1	3.1	3.86	9.2	9.2	9.2	5.7
-8	11.8	11.8	11.8	3.1	3.1	3.1	3.76	8.9	8.9	8.9	5.7
-9	11.5	11.5	11.5	3.1	3.1	3.1	3.67	8.6	8.6	8.6	5.7
-10	11.3	11.3	11.3	3.1	3.1	3.1	3.58	8.3	8.3	8.3	5.7
-11	11.0	11.0	11.0	3.1	3.1	3.1	3.49	8.0	8.0	8.0	5.7
-12	10.7	10.7	10.7	3.1	3.1	3.1	3.41	7.8	7.8	7.8	5.7
-13	10.4	10.4	10.4	3.1	3.1	3.1	3.33	7.5	7.5	7.5	5.7
-14	10.2	10.2	10.2	3.1	3.1	3.1	3.25	7.2	7.2	7.2	5.7
-15	9.9	9.9	9.9	3.1	3.1	3.1	3.18	7.0	7.0	7.0	5.7

-- attention: operating limits not reflected in performance table

ZHI14K1P-TFM_R410A_1_BWW

Th -OU	45										
[°C]	Qh nom [kW]	Qh min [kW]	Qh max [kW]	Pin nom [kW]	Pin min [kW]	Pin max [kW]	COP nom kW / kW	Qc nom [kW]	Qc min [kW]	Qc max [kW]	I nom [A]
25	25.4	25.4	25.4	3.7	3.7	3.7	6.91	22.0	22.0	22.0	6.3
24	24.9	24.9	24.9	3.7	3.7	3.7	6.73	21.4	21.4	21.4	6.3
23	24.3	24.3	24.3	3.7	3.7	3.7	6.56	20.9	20.9	20.9	6.4
22	23.8	23.8	23.8	3.7	3.7	3.7	6.39	20.3	20.3	20.3	6.4
21	23.3	23.3	23.3	3.7	3.7	3.7	6.22	19.8	19.8	19.8	6.4
20	22.8	22.8	22.8	3.8	3.8	3.8	6.06	19.3	19.3	19.3	6.4
19	22.3	22.3	22.3	3.8	3.8	3.8	5.91	18.8	18.8	18.8	6.4
18	21.8	21.8	21.8	3.8	3.8	3.8	5.75	18.3	18.3	18.3	6.5
17	21.4	21.4	21.4	3.8	3.8	3.8	5.61	17.8	17.8	17.8	6.5
16	20.9	20.9	20.9	3.8	3.8	3.8	5.46	17.3	17.3	17.3	6.5
15	20.5	20.5	20.5	3.8	3.8	3.8	5.33	16.9	16.9	16.9	6.5
14	20.0	20.0	20.0	3.9	3.9	3.9	5.19	16.4	16.4	16.4	6.5
13	19.6	19.6	19.6	3.9	3.9	3.9	5.06	16.0	16.0	16.0	6.6
12	19.1	19.1	19.1	3.9	3.9	3.9	4.93	15.5	15.5	15.5	6.6
11	18.7	18.7	18.7	3.9	3.9	3.9	4.81	15.1	15.1	15.1	6.6
10	18.3	18.3	18.3	3.9	3.9	3.9	4.69	14.7	14.7	14.7	6.6
9	17.9	17.9	17.9	3.9	3.9	3.9	4.57	14.3	14.3	14.3	6.6
8	17.5	17.5	17.5	3.9	3.9	3.9	4.46	13.9	13.9	13.9	6.6
7	17.1	17.1	17.1	3.9	3.9	3.9	4.35	13.5	13.5	13.5	6.6
6	16.8	16.8	16.8	3.9	3.9	3.9	4.25	13.1	13.1	13.1	6.7
5	16.4	16.4	16.4	4.0	4.0	4.0	4.14	12.7	12.7	12.7	6.7
4	16.0	16.0	16.0	4.0	4.0	4.0	4.04	12.3	12.3	12.3	6.7
3	15.7	15.7	15.7	4.0	4.0	4.0	3.95	12.0	12.0	12.0	6.7
2	15.3	15.3	15.3	4.0	4.0	4.0	3.85	11.6	11.6	11.6	6.7
1	15.0	15.0	15.0	4.0	4.0	4.0	3.76	11.2	11.2	11.2	6.7
0	14.6	14.6	14.6	4.0	4.0	4.0	3.67	10.9	10.9	10.9	6.7
-1	14.3	14.3	14.3	4.0	4.0	4.0	3.59	10.6	10.6	10.6	6.7
-2	14.0	14.0	14.0	4.0	4.0	4.0	3.51	10.2	10.2	10.2	6.7
-3	13.6	13.6	13.6	4.0	4.0	4.0	3.43	9.9	9.9	9.9	6.7
-4	13.3	13.3	13.3	4.0	4.0	4.0	3.35	9.6	9.6	9.6	6.7
-5	13.0	13.0	13.0	4.0	4.0	4.0	3.27	9.3	9.3	9.3	6.7
-6	12.7	12.7	12.7	4.0	4.0	4.0	3.20	9.0	9.0	9.0	6.7
-7	12.4	12.4	12.4	4.0	4.0	4.0	3.13	8.7	8.7	8.7	6.7
-8	12.1	12.1	12.1	4.0	4.0	4.0	3.06	8.4	8.4	8.4	6.7
-9	11.8	11.8	11.8	4.0	4.0	4.0	2.99	8.1	8.1	8.1	6.7
-10	11.6	11.6	11.6	3.9	3.9	3.9	2.93	7.9	7.9	7.9	6.7
-11	11.3	11.3	11.3	3.9	3.9	3.9	2.87	7.6	7.6	7.6	6.6
-12	11.0	11.0	11.0	3.9	3.9	3.9	2.81	7.3	7.3	7.3	6.6
-13	10.7	10.7	10.7	3.9	3.9	3.9	2.75	7.1	7.1	7.1	6.6
-14	10.5	10.5	10.5	3.9	3.9	3.9	2.69	6.8	6.8	6.8	6.6
-15	10.2	10.2	10.2	3.9	3.9	3.9	2.64	6.6	6.6	6.6	6.6

-- attention: operating limits not reflected in performance table

Th -OU		55										
	[°C]											
Ts -IN	Qh nom	Qh min	Qh max	Pin nom	Pin min	Pin max	COP nom	Qc nom	Qc min	Qc max	I nom	
[°C]	[kW]	[kW]	[kW]	[kW]	[kW]	[kW]	kW / kW	[kW]	[kW]	[kW]	[A]	
25	24.7	24.7	24.7	4.9	4.9	4.9	5.00	20.1	20.1	20.1	7.9	
24	24.2	24.2	24.2	5.0	5.0	5.0	4.88	19.6	19.6	19.6	8.0	
23	23.7	23.7	23.7	5.0	5.0	5.0	4.77	19.1	19.1	19.1	8.0	
22	23.2	23.2	23.2	5.0	5.0	5.0	4.66	18.6	18.6	18.6	8.0	
21	22.8	22.8	22.8	5.0	5.0	5.0	4.55	18.1	18.1	18.1	8.0	
20	22.3	22.3	22.3	5.0	5.0	5.0	4.45	17.6	17.6	17.6	8.1	
19	21.9	21.9	21.9	5.0	5.0	5.0	4.35	17.2	17.2	17.2	8.1	
18	21.5	21.5	21.5	5.1	5.1	5.1	4.25	16.7	16.7	16.7	8.1	
17	21.0	21.0	21.0	5.1	5.1	5.1	4.15	16.3	16.3	16.3	8.1	
16	20.6	20.6	20.6	5.1	5.1	5.1	4.06	15.9	15.9	15.9	8.1	
15	20.2	20.2	20.2	5.1	5.1	5.1	3.97	15.5	15.5	15.5	8.2	
14	19.8	19.8	19.8	5.1	5.1	5.1	3.88	15.0	15.0	15.0	8.2	
13	19.4	19.4	19.4	5.1	5.1	5.1	3.79	14.6	14.6	14.6	8.2	
12	19.0	19.0	19.0	5.1	5.1	5.1	3.71	14.2	14.2	14.2	8.2	
11	18.6	18.6	18.6	5.1	5.1	5.1	3.63	13.8	13.8	13.8	8.2	
10	18.3	18.3	18.3	5.1	5.1	5.1	3.55	13.5	13.5	13.5	8.2	
9	17.9	17.9	17.9	5.2	5.2	5.2	3.48	13.1	13.1	13.1	8.2	
8	17.5	17.5	17.5	5.2	5.2	5.2	3.40	12.7	12.7	12.7	8.2	
7	17.2	17.2	17.2	5.2	5.2	5.2	3.33	12.4	12.4	12.4	8.3	
6	16.8	16.8	16.8	5.2	5.2	5.2	3.26	12.0	12.0	12.0	8.3	
5	16.5	16.5	16.5	5.2	5.2	5.2	3.19	11.7	11.7	11.7	8.3	
4	16.2	16.2	16.2	5.2	5.2	5.2	3.13	11.3	11.3	11.3	8.3	
3	15.8	15.8	15.8	5.2	5.2	5.2	3.06	11.0	11.0	11.0	8.3	
2	15.5	15.5	15.5	5.2	5.2	5.2	3.00	10.7	10.7	10.7	8.3	
1	15.2	15.2	15.2	5.2	5.2	5.2	2.94	10.4	10.4	10.4	8.3	
0	14.9	14.9	14.9	5.2	5.2	5.2	2.88	10.0	10.0	10.0	8.3	
-1	14.6	14.6	14.6	5.2	5.2	5.2	2.82	9.7	9.7	9.7	8.3	
-2	14.3	14.3	14.3	5.2	5.2	5.2	2.77	9.4	9.4	9.4	8.2	
-3	14.0	14.0	14.0	5.1	5.1	5.1	2.71	9.2	9.2	9.2	8.2	
-4	13.7	13.7	13.7	5.1	5.1	5.1	2.66	8.9	8.9	8.9	8.2	
-5	13.4	13.4	13.4	5.1	5.1	5.1	2.61	8.6	8.6	8.6	8.2	
-6	13.1	13.1	13.1	5.1	5.1	5.1	2.56	8.3	8.3	8.3	8.2	
-7	12.8	12.8	12.8	5.1	5.1	5.1	2.51	8.0	8.0	8.0	8.2	
-8	12.5	12.5	12.5	5.1	5.1	5.1	2.46	7.8	7.8	7.8	8.2	
-9	12.2	12.2	12.2	5.1	5.1	5.1	2.42	7.5	7.5	7.5	8.1	
-10	12.0	12.0	12.0	5.0	5.0	5.0	2.37	7.3	7.3	7.3	8.1	
-11	11.7	11.7	11.7	5.0	5.0	5.0	2.33	7.0	7.0	7.0	8.1	
-12	11.4	11.4	11.4	5.0	5.0	5.0	2.29	6.8	6.8	6.8	8.0	
-13	11.2	11.2	11.2	5.0	5.0	5.0	2.25	6.5	6.5	6.5	8.0	
-14	10.9	10.9	10.9	4.9	4.9	4.9	2.21	6.3	6.3	6.3	8.0	
-15	10.7	10.7	10.7	4.9	4.9	4.9	2.17	6.1	6.1	6.1	7.9	

-- attention: operating limits not reflected in performance table

Th -OU	65 (T-max)										
	Qh nom	Qh min	Qh max	Pin nom	Pin min	Pin max	COP nom	Qc nom	Qc min	Qc max	I nom
[°C]	[kW]	[kW]	[kW]	[kW]	[kW]	[kW]	kW / kW	[kW]	[kW]	[kW]	[A]
25	24.1	24.1	24.1	6.5	6.5	6.5	3.72	18.0	18.0	18.0	10.1
24	23.6	23.6	23.6	6.5	6.5	6.5	3.64	17.6	17.6	17.6	10.1
23	23.2	23.2	23.2	6.5	6.5	6.5	3.57	17.1	17.1	17.1	10.1
22	22.8	22.8	22.8	6.5	6.5	6.5	3.49	16.7	16.7	16.7	10.1
21	22.4	22.4	22.4	6.5	6.5	6.5	3.42	16.3	16.3	16.3	10.2
20	22.0	22.0	22.0	6.5	6.5	6.5	3.36	15.9	15.9	15.9	10.2
19	21.6	21.6	21.6	6.6	6.6	6.6	3.29	15.5	15.5	15.5	10.2
18	21.2	21.2	21.2	6.6	6.6	6.6	3.22	15.1	15.1	15.1	10.2
17	20.8	20.8	20.8	6.6	6.6	6.6	3.16	14.7	14.7	14.7	10.2
16	20.4	20.4	20.4	6.6	6.6	6.6	3.10	14.3	14.3	14.3	10.2
15	20.1	20.1	20.1	6.6	6.6	6.6	3.04	13.9	13.9	13.9	10.3
14	19.7	19.7	19.7	6.6	6.6	6.6	2.98	13.5	13.5	13.5	10.3
13	19.4	19.4	19.4	6.6	6.6	6.6	2.93	13.2	13.2	13.2	10.3
12	19.0	19.0	19.0	6.6	6.6	6.6	2.87	12.8	12.8	12.8	10.3
11	18.7	18.7	18.7	6.6	6.6	6.6	2.82	12.5	12.5	12.5	10.3
10	18.3	18.3	18.3	6.6	6.6	6.6	2.77	12.1	12.1	12.1	10.3
9	18.0	18.0	18.0	6.6	6.6	6.6	2.72	11.8	11.8	11.8	10.3
8	17.7	17.7	17.7	6.6	6.6	6.6	2.67	11.5	11.5	11.5	10.3
7	17.4	17.4	17.4	6.6	6.6	6.6	2.62	11.2	11.2	11.2	10.3
6	17.0	17.0	17.0	6.6	6.6	6.6	2.57	10.9	10.9	10.9	10.3
5	16.7	16.7	16.7	6.6	6.6	6.6	2.53	10.5	10.5	10.5	10.3
4	16.4	16.4	16.4	6.6	6.6	6.6	2.48	10.2	10.2	10.2	10.3
3	16.1	16.1	16.1	6.6	6.6	6.6	2.44	10.0	10.0	10.0	10.3
2	15.8	15.8	15.8	6.6	6.6	6.6	2.40	9.7	9.7	9.7	10.3
1	15.5	15.5	15.5	6.6	6.6	6.6	2.36	9.4	9.4	9.4	10.2
0	15.2	15.2	15.2	6.6	6.6	6.6	2.32	9.1	9.1	9.1	10.2
-1	15.0	15.0	15.0	6.6	6.6	6.6	2.28	8.8	8.8	8.8	10.2
-2	14.7	14.7	14.7	6.5	6.5	6.5	2.24	8.6	8.6	8.6	10.2
-3	14.4	14.4	14.4	6.5	6.5	6.5	2.20	8.3	8.3	8.3	10.2
-4	14.1	14.1	14.1	6.5	6.5	6.5	2.17	8.0	8.0	8.0	10.1
-5	13.9	13.9	13.9	6.5	6.5	6.5	2.13	7.8	7.8	7.8	10.1
-6	13.6	13.6	13.6	6.5	6.5	6.5	2.10	7.5	7.5	7.5	10.1
-7	13.3	13.3	13.3	6.4	6.4	6.4	2.07	7.3	7.3	7.3	10.0
-8	13.1	13.1	13.1	6.4	6.4	6.4	2.04	7.1	7.1	7.1	10.0
-9	12.8	12.8	12.8	6.4	6.4	6.4	2.00	6.8	6.8	6.8	10.0
-10	12.5	12.5	12.5	6.4	6.4	6.4	1.97	6.6	6.6	6.6	9.9
-11	12.3	12.3	12.3	6.3	6.3	6.3	1.94	6.4	6.4	6.4	9.9
-12	12.0	12.0	12.0	6.3	6.3	6.3	1.91	6.2	6.2	6.2	9.8
-13	11.8	11.8	11.8	6.3	6.3	6.3	1.89	5.9	5.9	5.9	9.8
-14	11.5	11.5	11.5	6.2	6.2	6.2	1.86	5.7	5.7	5.7	9.7
-15	11.3	11.3	11.3	6.2	6.2	6.2	1.83	5.5	5.5	5.5	9.7

-- attention: operating limits not reflected in performance table

Tc -OU		W 12 / 7 °C									
Ts -IN	Qc nom	Qc min	Qc max	Pin nom	Pin min	Pin max	EER	Qh nom	Qh min	Qh max	I nom
[°C]	[kW]	[kW]	[kW]	[kW]	[kW]	[kW]	kW / kW	[kW]	[kW]	[kW]	[A]
40	10.6	10.6	10.6	4.3	4.3	4.3	2.45	14.7	14.7	14.7	7.2
39	10.7	10.7	10.7	4.2	4.2	4.2	2.53	14.7	14.7	14.7	7.0
38	10.8	10.8	10.8	4.1	4.1	4.1	2.61	14.6	14.6	14.6	6.9
37	10.9	10.9	10.9	4.0	4.0	4.0	2.70	14.6	14.6	14.6	6.8
36	10.9	10.9	10.9	3.9	3.9	3.9	2.79	14.6	14.6	14.6	6.6
35	11.0	11.0	11.0	3.8	3.8	3.8	2.88	14.6	14.6	14.6	6.5
34	11.1	11.1	11.1	3.7	3.7	3.7	2.97	14.6	14.6	14.6	6.4
33	11.2	11.2	11.2	3.6	3.6	3.6	3.06	14.6	14.6	14.6	6.3
32	11.2	11.2	11.2	3.6	3.6	3.6	3.16	14.5	14.5	14.5	6.2
31	11.3	11.3	11.3	3.5	3.5	3.5	3.26	14.5	14.5	14.5	6.1
30	11.4	11.4	11.4	3.4	3.4	3.4	3.37	14.5	14.5	14.5	6.0
29	11.4	11.4	11.4	3.3	3.3	3.3	3.47	14.5	14.5	14.5	5.9
28	11.5	11.5	11.5	3.2	3.2	3.2	3.58	14.5	14.5	14.5	5.8
27	11.5	11.5	11.5	3.1	3.1	3.1	3.69	14.5	14.5	14.5	5.7
26	11.6	11.6	11.6	3.0	3.0	3.0	3.81	14.4	14.4	14.4	5.6
25	11.7	11.7	11.7	3.0	3.0	3.0	3.93	14.4	14.4	14.4	5.5
24	11.7	11.7	11.7	2.9	2.9	2.9	4.05	14.4	14.4	14.4	5.4
23	11.8	11.8	11.8	2.8	2.8	2.8	4.17	14.4	14.4	14.4	5.3
22	11.8	11.8	11.8	2.7	2.7	2.7	4.30	14.4	14.4	14.4	5.2
21	11.9	11.9	11.9	2.7	2.7	2.7	4.44	14.4	14.4	14.4	5.1
20	11.9	11.9	11.9	2.6	2.6	2.6	4.57	14.4	14.4	14.4	5.1

Tc [°C]		W 23 / 18 °C									
0	Qc nom	Qc min	Qc max	Pin nom	Pin min	Pin max	EER	Qh nom	Qh min	Qh max	I nom
[°C]	[kW]	[kW]	[kW]	[kW]	[kW]	[kW]	kW / kW	[kW]	[kW]	[kW]	[A]
40	14.3	14.3	14.3	4.3	4.3	4.3	3.29	18.3	18.3	18.3	7.1
39	14.4	14.4	14.4	4.2	4.2	4.2	3.40	18.3	18.3	18.3	6.9
38	14.5	14.5	14.5	4.1	4.1	4.1	3.51	18.3	18.3	18.3	6.8
37	14.6	14.6	14.6	4.0	4.0	4.0	3.63	18.3	18.3	18.3	6.7
36	14.7	14.7	14.7	3.9	3.9	3.9	3.75	18.3	18.3	18.3	6.5
35	14.8	14.8	14.8	3.8	3.8	3.8	3.87	18.3	18.3	18.3	6.4
34	14.9	14.9	14.9	3.7	3.7	3.7	4.00	18.3	18.3	18.3	6.3
33	15.0	15.0	15.0	3.6	3.6	3.6	4.13	18.3	18.3	18.3	6.2
32	15.1	15.1	15.1	3.6	3.6	3.6	4.26	18.4	18.4	18.3	6.1
31	15.2	15.2	15.2	3.5	3.5	3.5	4.40	18.4	18.4	18.3	5.9
30	15.3	15.3	15.3	3.4	3.4	3.4	4.54	18.4	18.4	18.3	5.8
29	15.4	15.4	15.4	3.3	3.3	3.3	4.68	18.4	18.4	18.3	5.7
28	15.5	15.5	15.5	3.2	3.2	3.2	4.83	18.4	18.4	18.3	5.6
27	15.6	15.6	15.6	3.1	3.1	3.1	4.99	18.4	18.4	18.3	5.5
26	15.7	15.7	15.7	3.0	3.0	3.0	5.14	18.4	18.4	18.3	5.4
25	15.8	15.8	15.8	3.0	3.0	3.0	5.31	18.4	18.4	18.3	5.4
24	15.8	15.8	15.8	2.9	2.9	2.9	5.47	18.4	18.4	18.3	5.3
23	15.9	15.9	15.9	2.8	2.8	2.8	5.65	18.5	18.5	18.3	5.2
22	16.0	16.0	16.0	2.7	2.7	2.7	5.82	18.5	18.5	18.4	5.1
21	16.1	16.1	16.1	2.7	2.7	2.7	6.00	18.5	18.5	18.4	5.0
20	16.1	16.1	16.1	2.6	2.6	2.6	6.19	18.5	18.5	18.4	5.0

-- attention: operating limits not reflected in performance table

LEGEND:

Ts-IN: Temperature renewable source - inlet [°C]
Th-OU: Temperature heating - outlet (flow) [°C]
Tc-OU: Temperature cooling - outlet (flow) [°C]
Qh nom: Heating capacity nominal
Qh min: Heating capacity minimal
Qh max: Heating capacity maximal
Pin nom: Power input at nominal heating capacity
Pin min: Power input at minimal heating capacity
Pin max: Power input at maximal heating capacity
COP nom: coefficient of performance at nominal heating capacity
Qc nom: cooling / heat extraction capacity at nominal heating capacity
Qc min: cooling / heat extraction at minimal heating capacity
Qc max: cooling / heat extraction at maximal heating capacity
I nom: Current at nominal heating capacity
EER: energy efficiency ratio at nominal cooling capacity

Operating limits

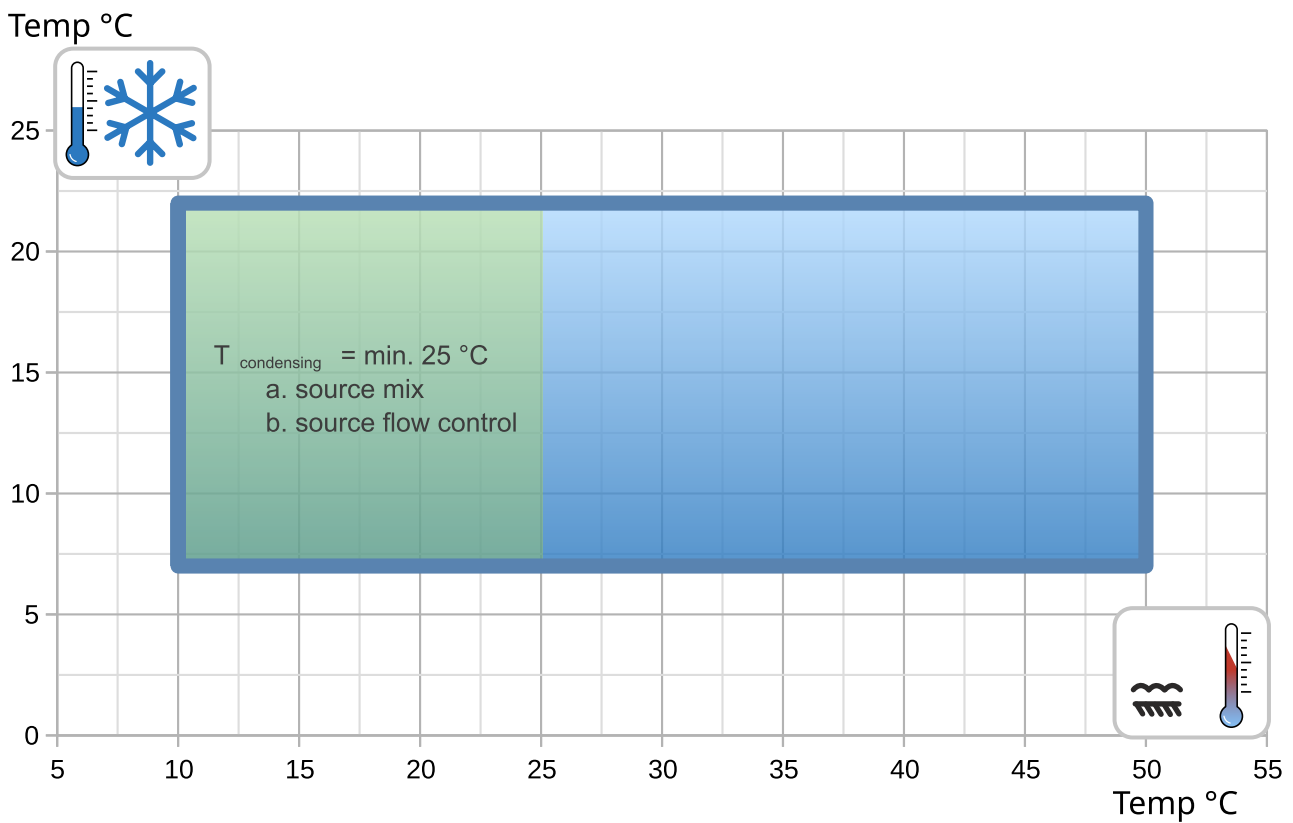
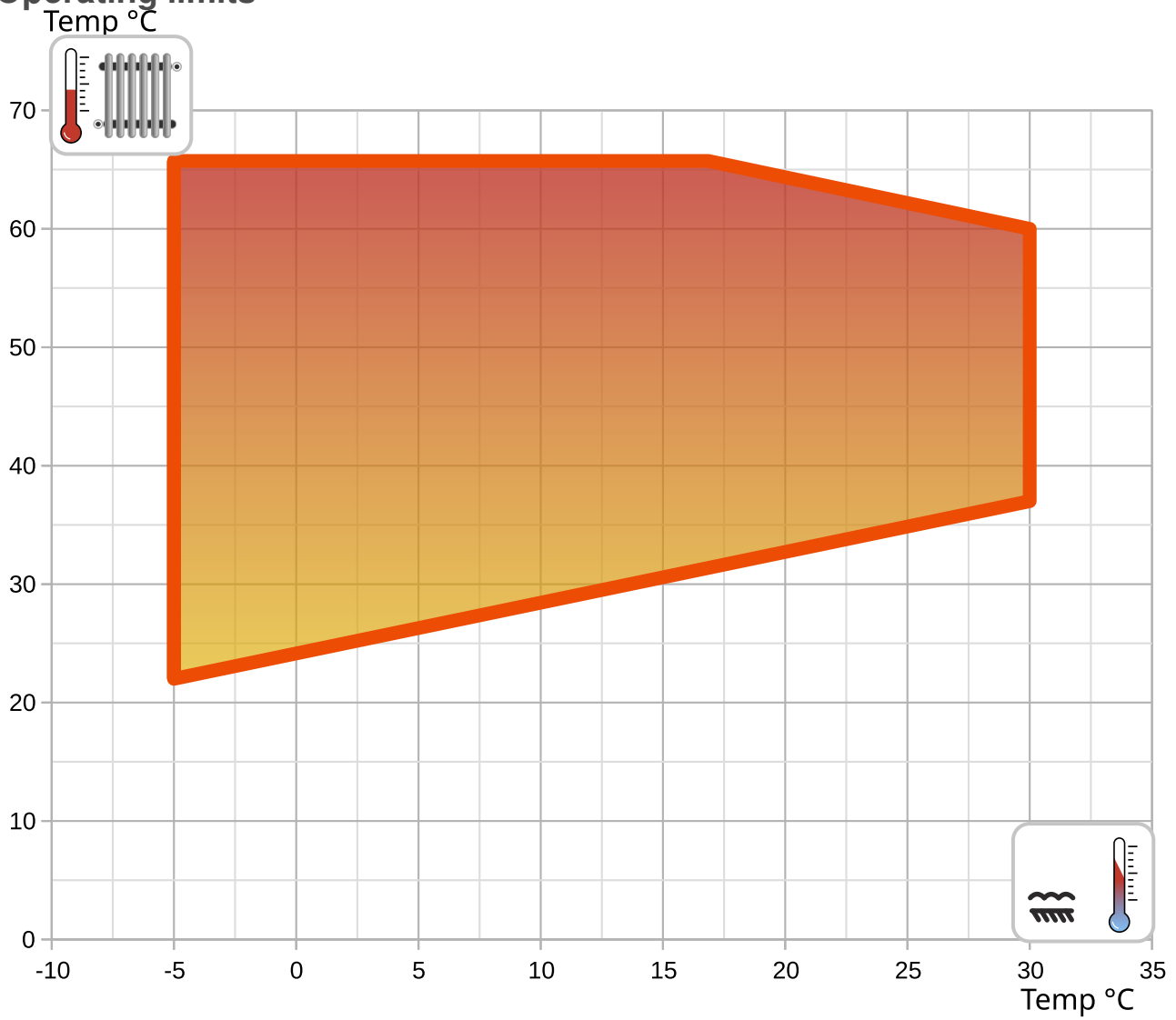

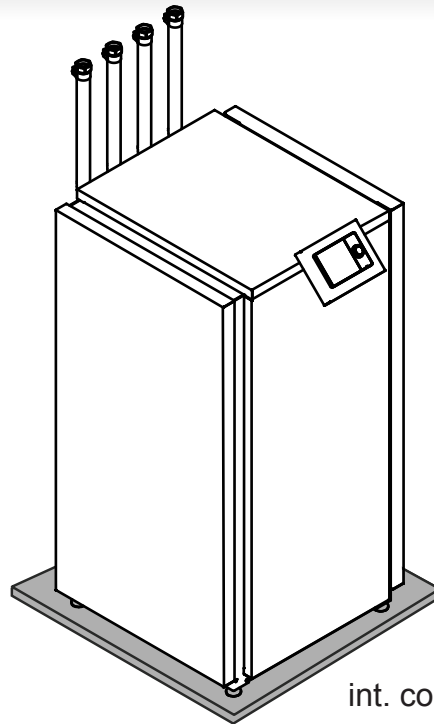
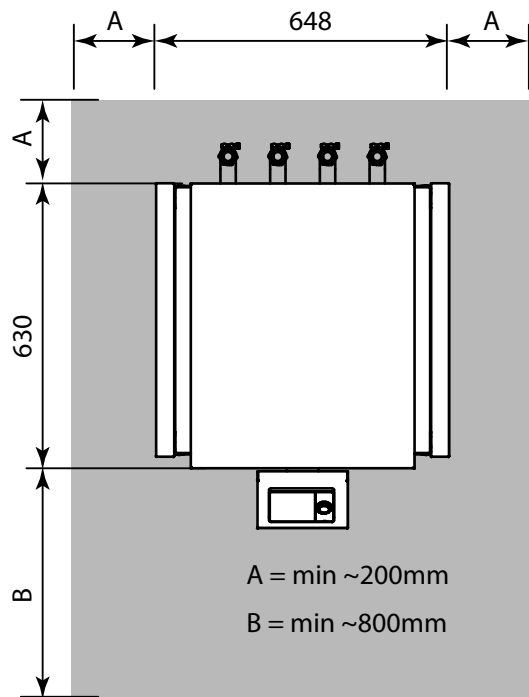
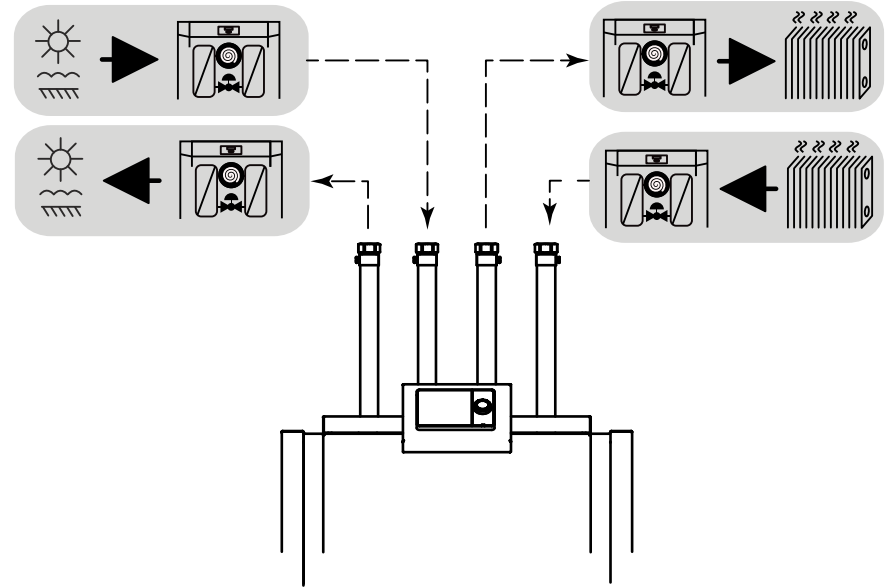
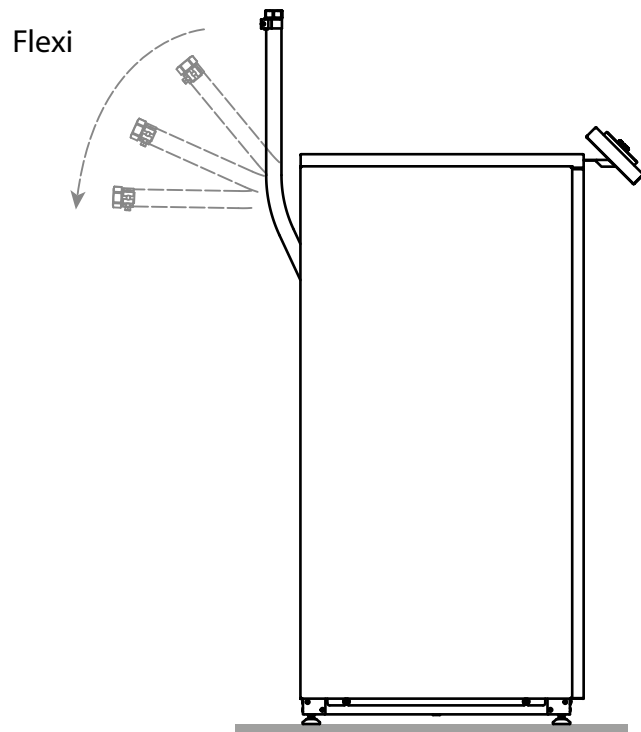
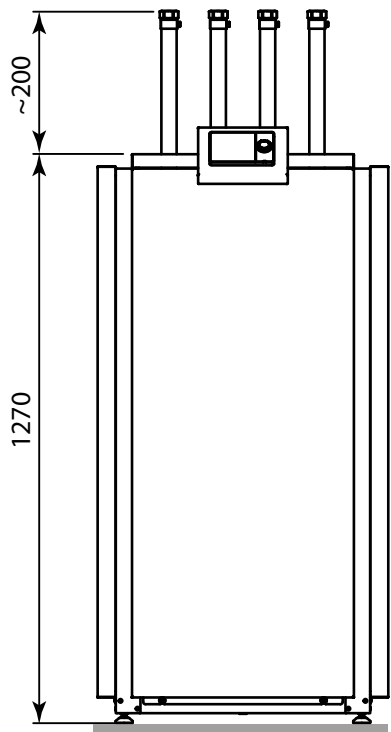

int. code: VN600

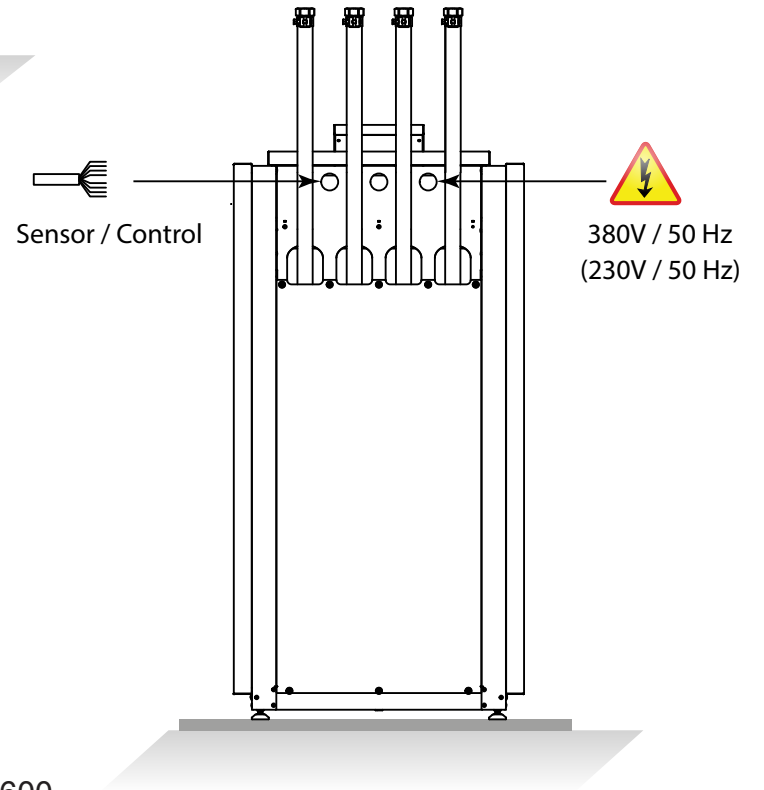

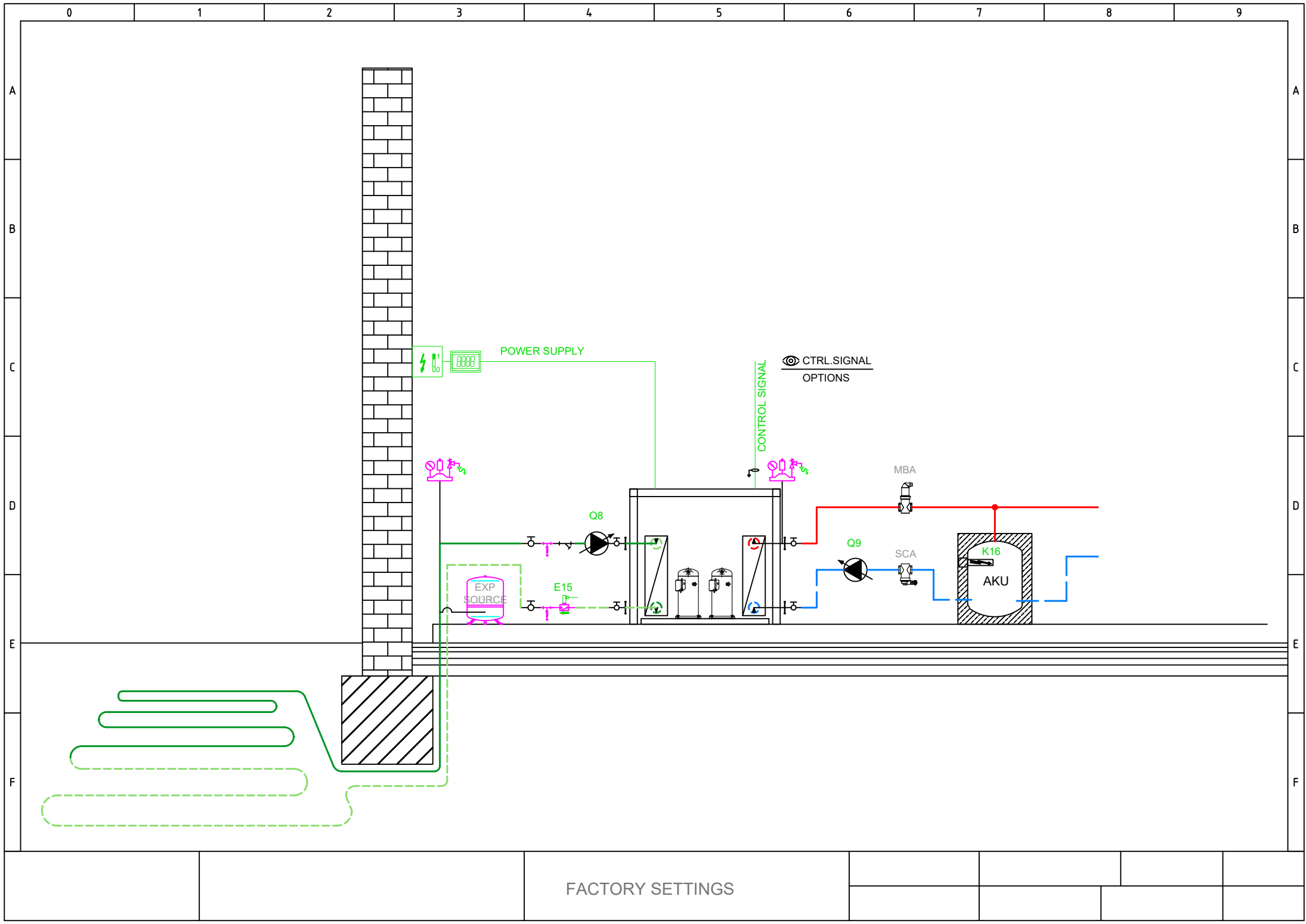

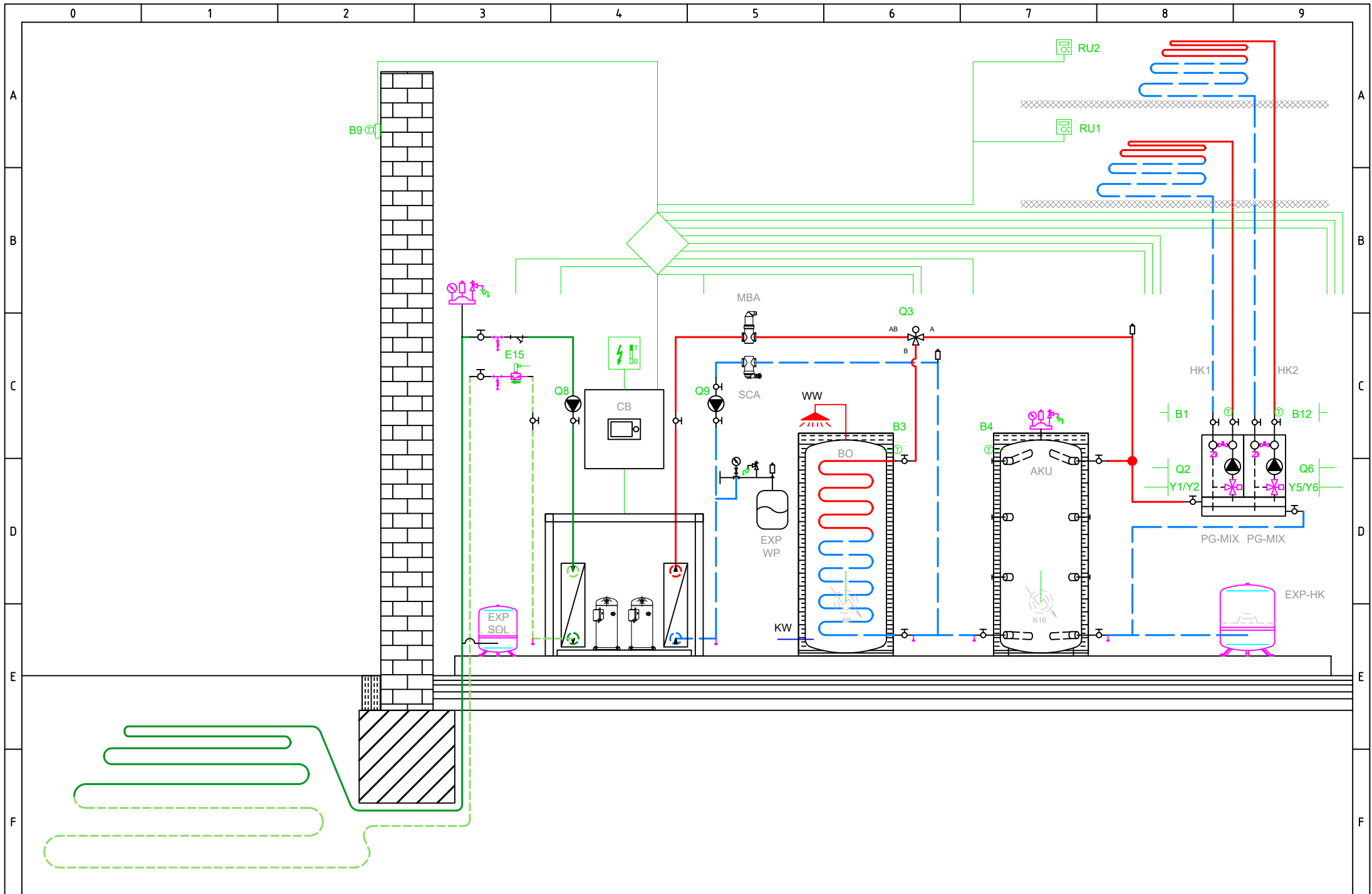

BASIC APPLICATION

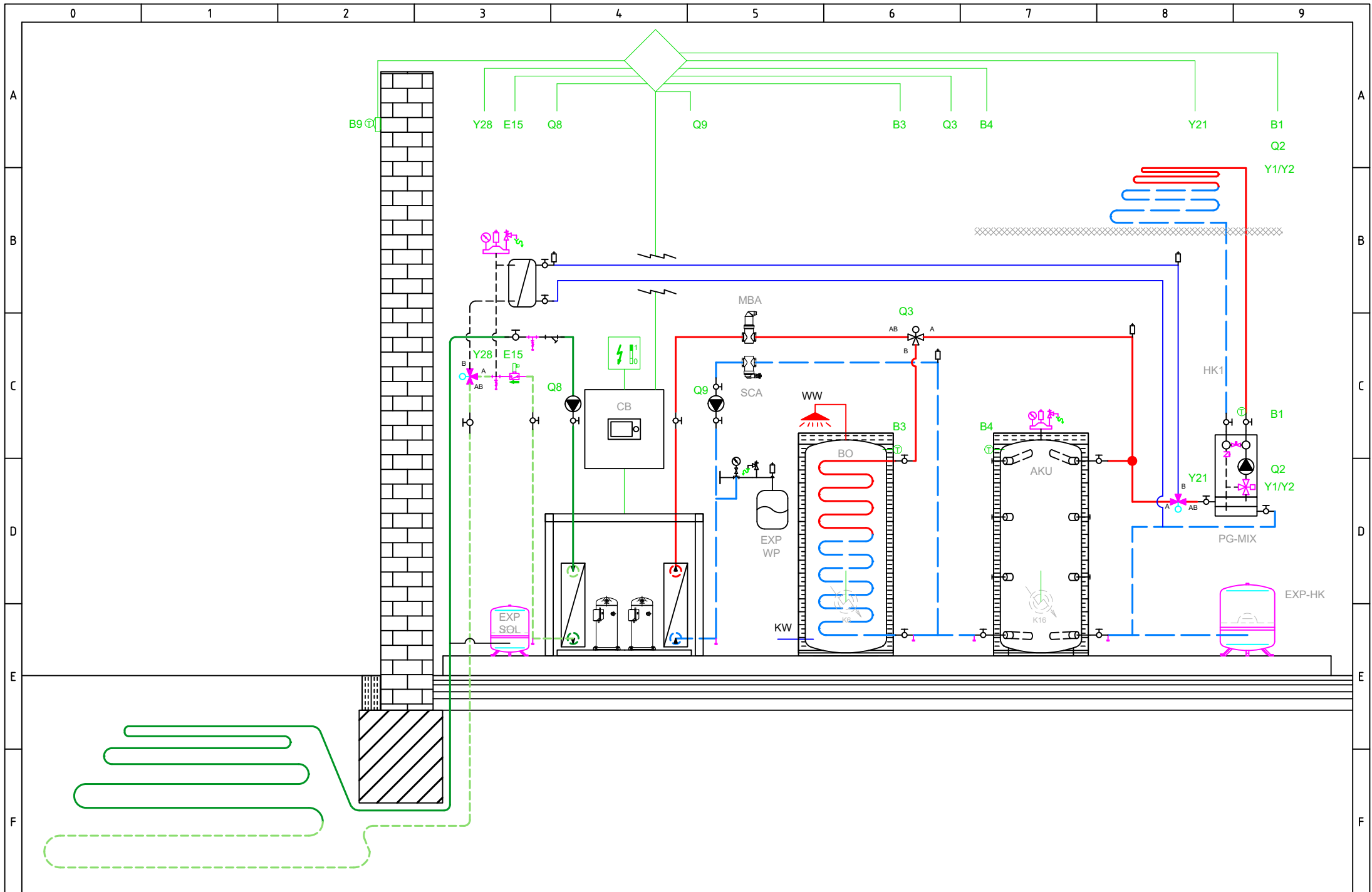

OPTIONAL APPLICATION

Total: max 6A
1 x QX...: max 2A

Main power supply 230V / 50 Hz
Ground
Neutral conductor

- E9 Low-pressure switch E9
- E10 High-pressure switch E10
- E15 Flow switch source E15
- E24 Flow switch consumers E24
- E6 Electrical utility lock E6
- E12 Overload compressor 2 E12
- E21 Mains supervision E21
- E22 Mains supervision E22
- E23 Mains supervision E23
- E11 Overload compressor 1 E11
- K1 Compressor stage 1 K1

Q8 Source pump Q8

Q9 Condenser pump Q9

K10 Alarm output K10

K40 Crankcase heater K40

K81 Valve evaporator K81

K82 Valve EVI K82

K2 Compressor stage 2 K2

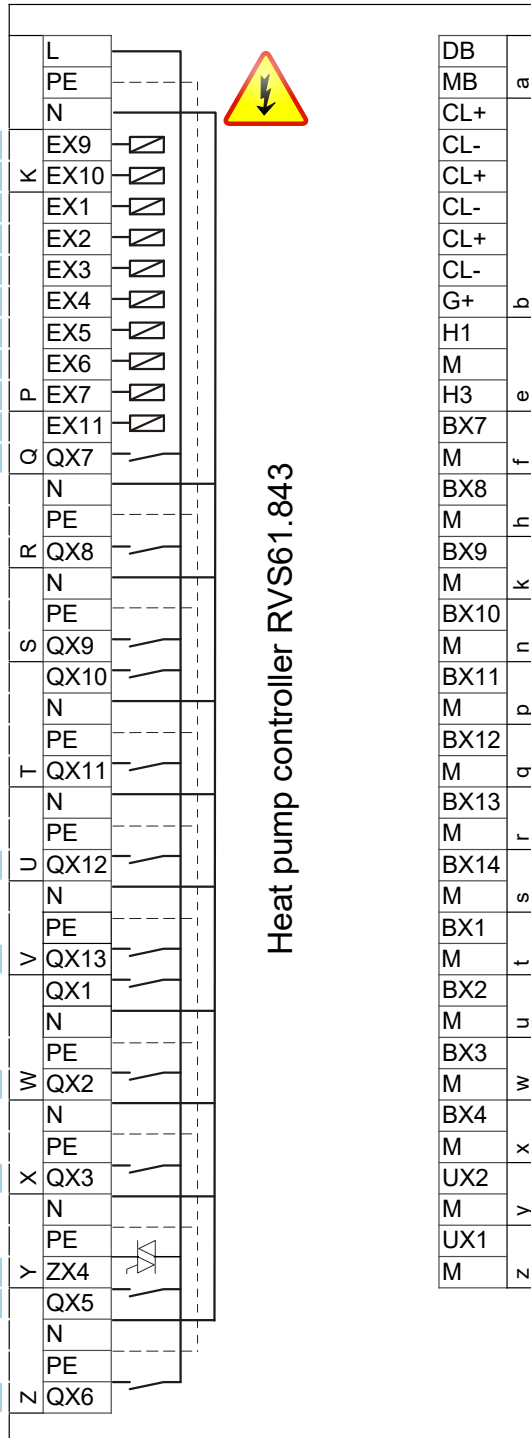

DB		LPB Bus data
MB	a	LPB Bus GND
CL+		Room unit QAA...
CL-		Room unit QAA...
CL+		Room unit QAA... 2.
CL-		Room unit QAA... 2.
CL+		Room unit QAA... 3.
CL-		Room unit QAA... 3.
G+	b	12V supply → OUT
H1		
M		
H3	e	Consumer request VK1
BX7		B81 Hot-gas sensor K1 B81
M	f	
BX8		
M	h	
BX9		
M	k	
BX10		B21 HP flow sensor B21
M	n	
BX11		
M	p	
BX12		B71 HP return sensor B71
M	q	
BX13		B91 Source inlet sensor B91
M	r	
BX14		B84 Source outl sens B92/B84
M	s	
BX1		
M	t	
BX2		
M	u	
BX3		B83 Refrig sensor liquid B83
M	w	
BX4		B82 Hot-gas sensor K2 B82
M	x	
UX2		Condenser pump Q9
M	y	0..10 V Signal
UX1		Source pump Q8
M	z	0..10 V Signal



- AVS75.390
- AVS75.391
- AVS75.370

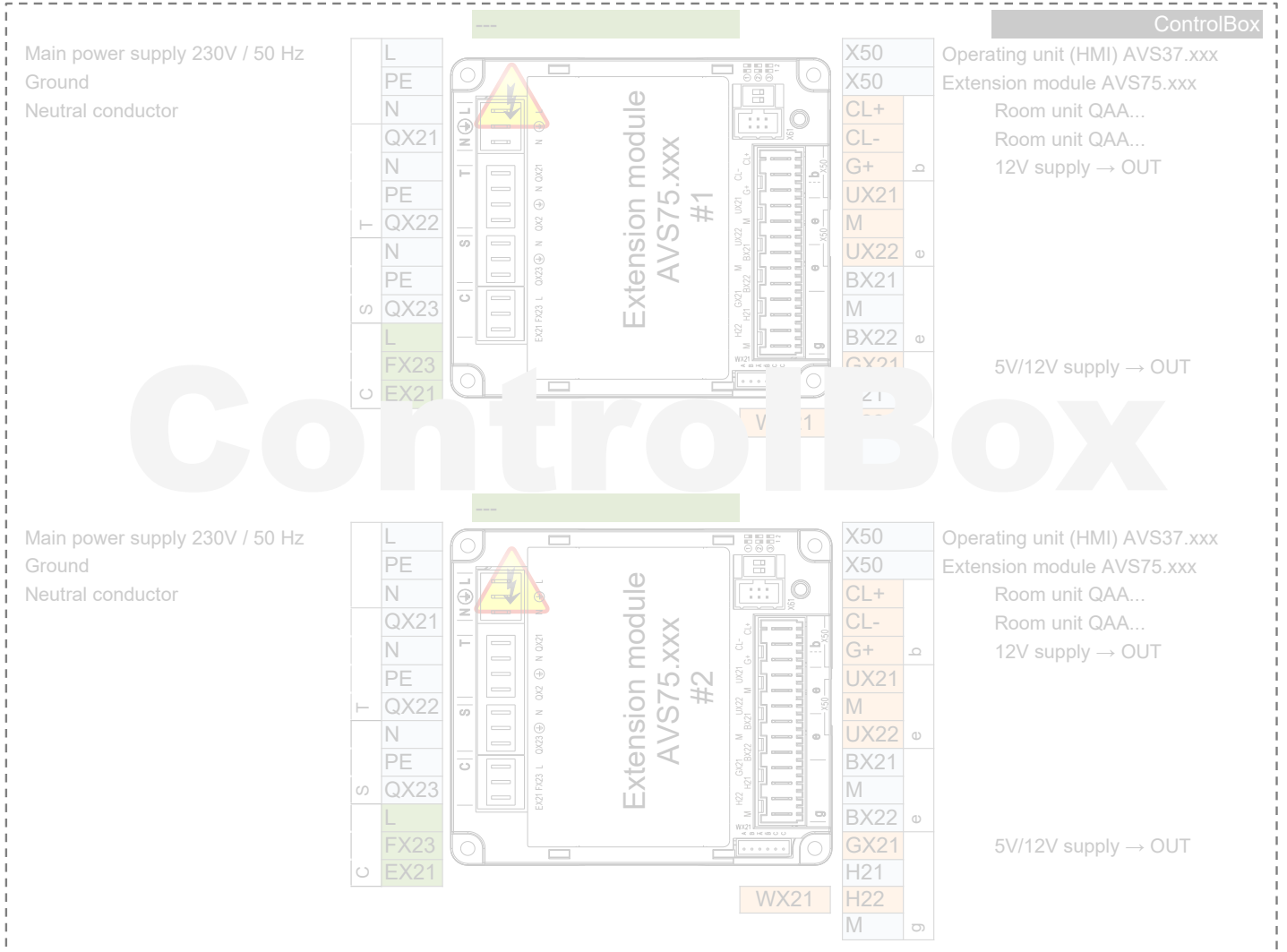

HEAT PUMP

EXTERNAL
INTERNAL

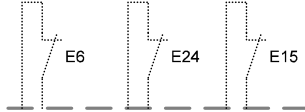
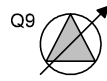
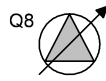

K1

K2

K82

K81

K40

K10

Q8 UX1

Q9 UX2

E11
KRW1
F1K
E11

E12
KRW2
F2K
E12

E6

Q9.ERR
F1S
E24

Q8.ERR
F1Z
E15

E10

E9

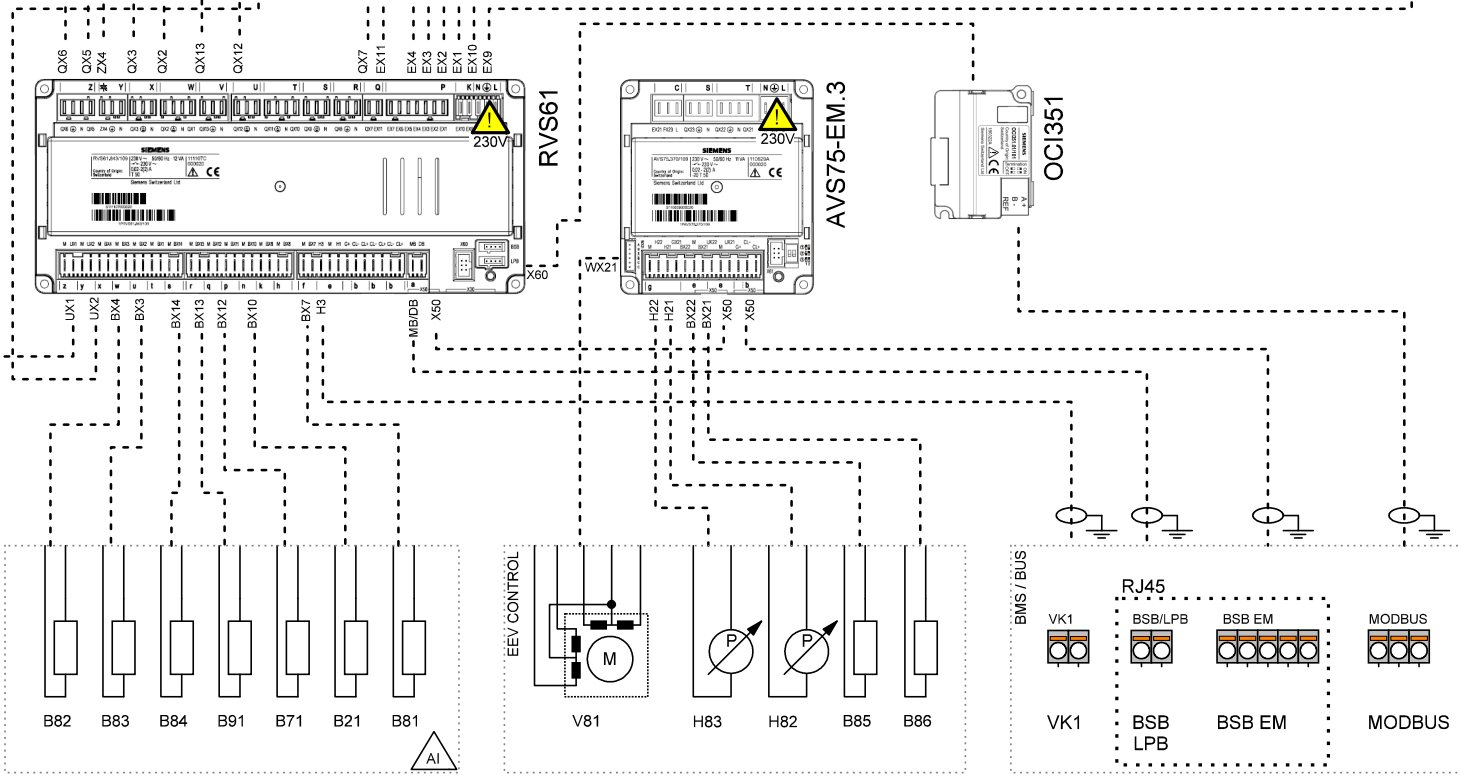
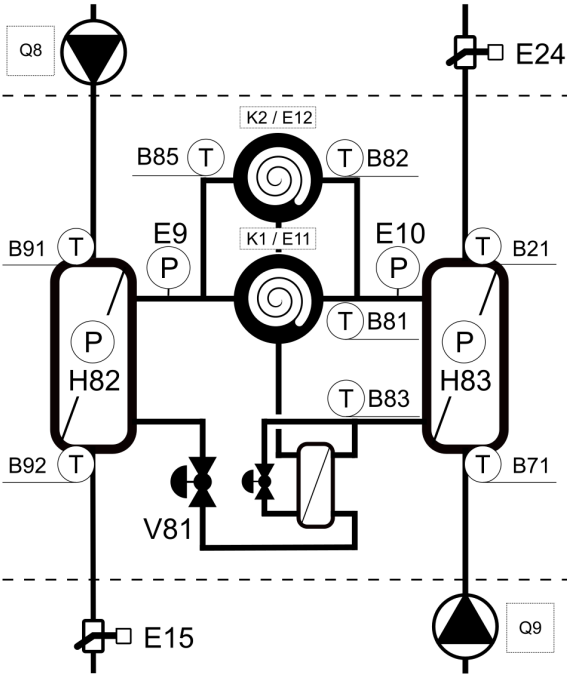
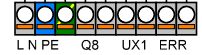
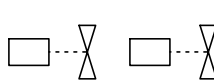

PWR SPLY: 3~ 400V, 50 Hz
CTRL: 1~ 230V, 50 HZ

Company
Title

TBW-TWW

Version / Note
05/2024

Number

Created by

Date

Page
1

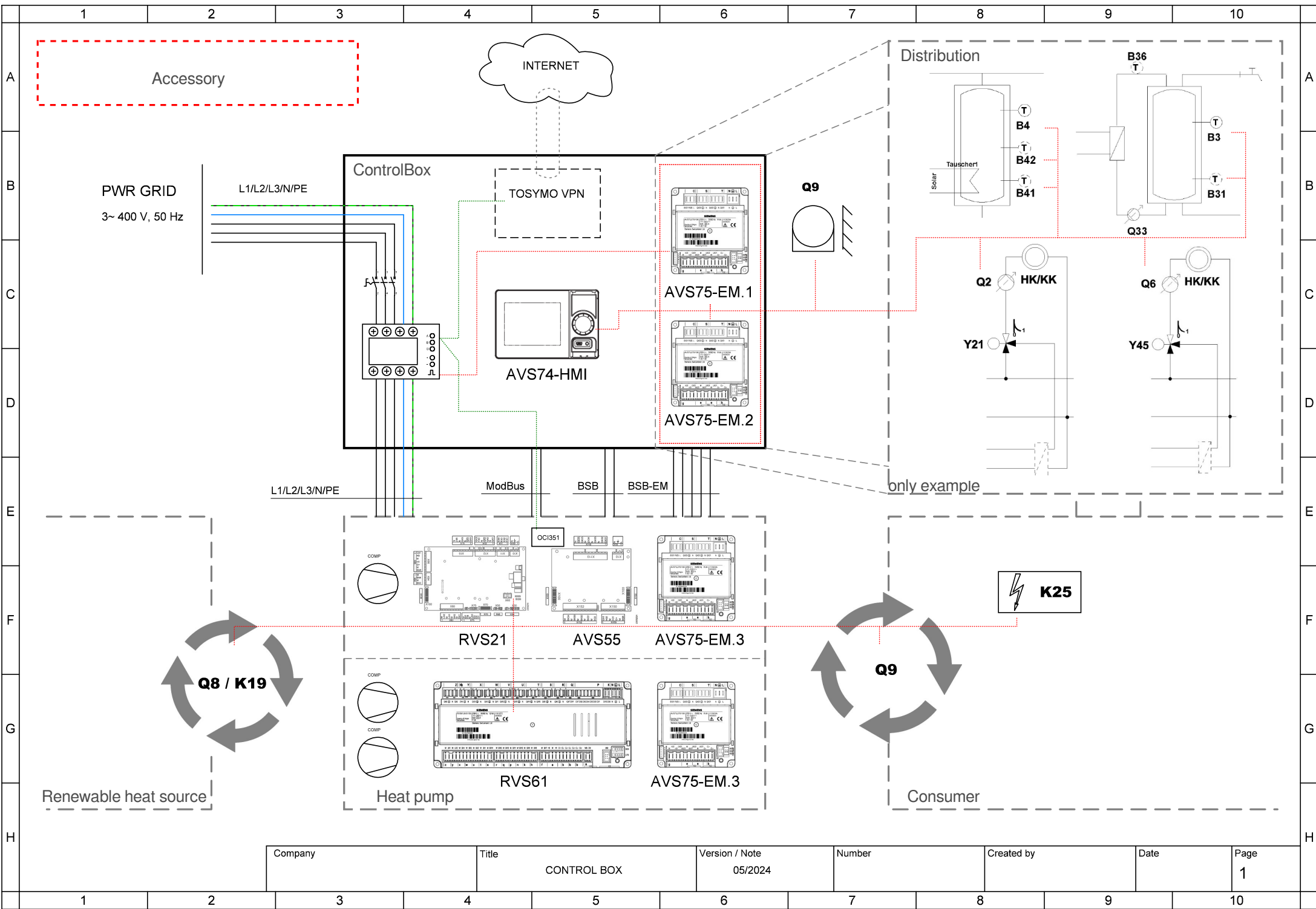

Company	Title	Version / Note	Number	Created by	Date	Page
	CONTROL BOX	05/2024				1



Company	Title	Version / Note	Number	Created by	Date	Page
	CONTROL BOX	05/2024				2



Company	Title	Version / Note	Number	Created by	Date	Page
	CONTROL BOX	05/2024				3



Company	Title	Version / Note	Number	Created by	Date	Page
	CONTROL BOX	05/2024				4

- AVS75.390
- AVS75.391
- AVS75.370

- AVS75.370**
 Main power supply 230V / 50 Hz
 Ground
 Neutral conductor
Y1 Mixing valve Open

Y2 Mixing valve Close

Q2 Heat circuit pump HC1 Q2

L Phase 230V
E61 Smart grid E61

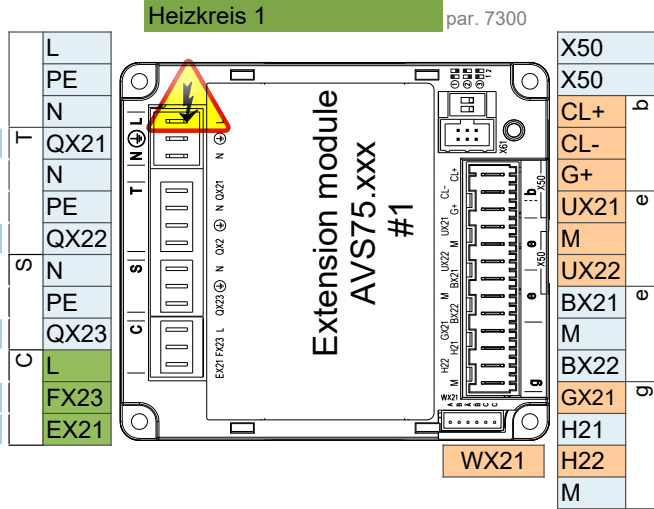

- Extension module AVS75.xxx
 Room unit QAA...
 Room unit QAA...

B1 Flow sensor 1

 Pulse count

- AVS75.370**
 Main power supply 230V / 50 Hz
 Ground
 Neutral conductor
Q3 DHW ctrl elem Q3

K6 El imm heater DHW K6

Q6 Heat circuit pump HC2 Q6

L Phase 230V
E62 Smart grid E62

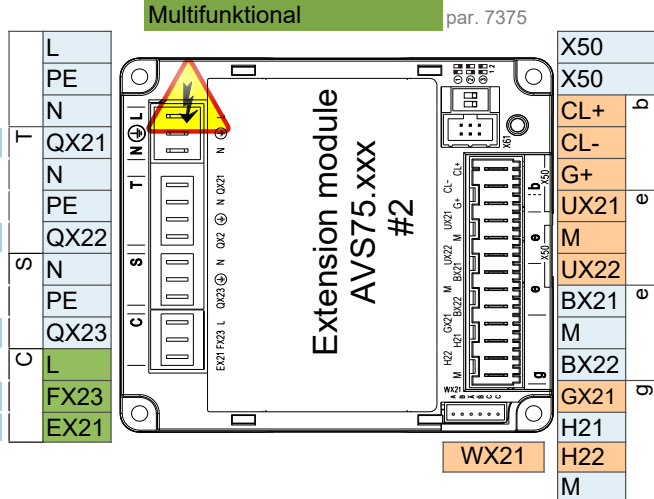

- Operating unit (HMI) AVS37.xxx
 Extension module AVS75.xxx
 Room unit QAA...
 Room unit QAA...

B3 DHW sensor B3

B4 Buffer sensor B4

- Main power supply 230V / 50 Hz
 Ground
 Neutral conductor

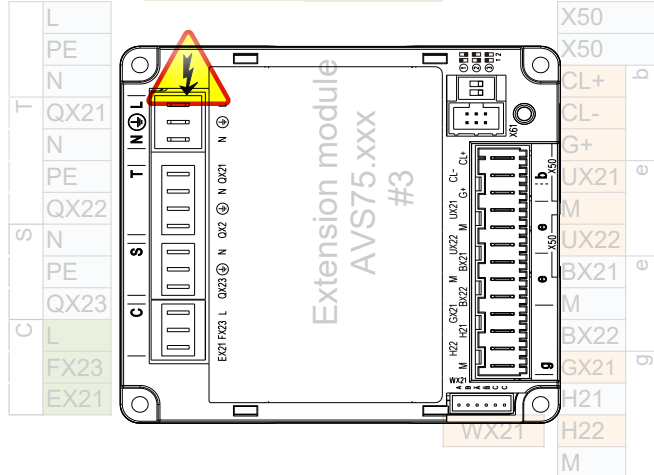

- Operating unit (HMI) AVS37.xxx
 Extension module AVS75.xxx
 Room unit QAA...
 Room unit QAA...

Attention: Extension module 3 is inside the heat pump

Control connection options

1 ControlBox

ControlBox, with two built-in extension modules, enables numerous options for application control on the consumer side behind the heat pump. For more, see the ControlBox schematic and the application diagrams sheet.

2 Fix flow temperature setpoint - On / Off dry (potential free) contact

2 wire shielded cable 2 x 0.5 mm² - Setpoint = 45°C (editable by param. 1859)

Connection terminal - see wiring diagram

3 Analog 0..10V flow temperature setpoint control

2 wire shielded cable 2 x 0.5 mm² - Setpoint: 0V = 16°C ~ 10V = 60°C (editable in parameter set)

Connection terminal - see wiring diagram

4 ModBus RTU communication command

3 wire shielded cable min. 3 x 0.25mm²

For ModBus mapping table contact technical support

5 MQTT IoT communication protocol

For more information contact technical support