

Základné údaje o výkone - WAMAK BW 14 EVI

Vykurovanie - EN 14511		
Tepelný výkon [kW]	B0 / W35 (max)	14.5
	B0 / W35 (min)	14.5
	B0 / W34	14.4
Elektrický príkon [kW]	B0 / W35 (max)	3.1
	B0 / W35 (min)	3.1
	B0 / W34	3.0
Tepelná účinnosť [COP]	B0 / W35 (max)	4.63
	B0 / W35 (min)	4.63
	B0 / W34	4.74
Sezónna tepelná účinnosť vykurovania - SCOP EN 14825		
Stredná klim. zóna / Nízka teplota [35°C]	SCOP	5.29
	η [%]	211.4
	Label	A+++
	Qhe [kWh]	5627.5
	Pdesignh [kW]	14.5
	Tbivalent [°C]	-10
Chladenie		
Chladiaci výkon - [kW]	A35 / W23-18	14.8
	A25 / W23-18	15.8
	A35 / W12-7	14.8
	A25 / W12-7	14.8
Sezónna účinnosť chladenia - SEER EN 14825		
[W 23 / 18°C]	SEER	5.58
	Qce [kWh]	1479.7
	η_c [%]	223.3
Zvuk EN 12102		
Zvuk - výkon - Lw	dB(A)	45.2
Zvuk - tlak - Lp	1 m dB(A)	37.2
	5 m dB(A)	23.2
	10 m dB(A)	17.2
Strojné a prevádzkové informácie		
Typ kompresoru (3~ 400/50)	SCROLL / 1 /	Zap/Vyp
Chladivo	R410A (GWP - 2088)	2.4 kg
Prevádzkové hraničné teploty vykurovania - (min / max) [°C]		25 / 65
Prevádzkové hraničné teploty zdroja - (min / max) [°C]		-10 (7) / 30
Váha zariadenia		155 kg

Hlavné technické údaje - WAMAK BW 14 EVI

Označenie krytovania			VN600			Údaje strany odovzdania tepelnej energie		
Základné rozmery	Výška [mm]	1270	Prevádzkové hraničné teploty vykurovania	MAX [°C]	65			
	Šírka [mm]	650		MIN [°C]	25			
	Dĺžka [mm]	630		viac vid. diagram prevádzkových limitov				
Váha zariadenia [kg]	155		Kondenzátor	Pripojovacia dimenzia	1.1/4 "			
Farba krytovania	Sivá			Typ	BPHE			
IP trieda krytovania	IP20			Počet	1			
Chladivový okruh				Materiál	AISI 316			
Kompresor	Typ	Scroll	Maximálny prevádzkový tlak - chladivo [bar]			45		
	Výkonové stupňe	1	Maximálny prevádzkový tlak - Voda [bar]			6		
	Zap/Vyp		Testovací pretlak [bar]			70		
	Účinník Cosφ	0.77	Teplonosné médium			Voda		
	Odpor vynutia kompresora	2.33 Ohm	Objemový prietok @ dT 5K (nom) - Voda [m3/h]			2.50		
Chladivo		R410A	Vnútorná tlaková strata - Voda [kPa]			12		
	Objem	2.4 kg	ECM nízkoenergetické čerpadlo spotreby			UPM3 25-75		
	GWP	2088	Snímač prietoku strana spotreby - analog			0..10V		
	Bezpečnostná trieda	A1	Teplotný spád	@ 35°C (nom)	5 K			
Typ oleja v okruhu	POE RL32-3MAF	@ 55°C		8 K				
Objem oleja	1.24 L	@ 65°C		10 K				
Maximálny tlak chladiva [bar]	45		Údaje strany odberu obnoviteľnej energie					
PED trieda	1		Prevádzkové hraničné teploty zdroja	MIN [°C]	-10 (7)			
EVI - vstrek chladiva s ekonomizérom				MAX [°C]	30			
Údaje elektrického pripojenia			viac vid. diagram prevádzkových limitov					
Elektro napájanie [#~ V/Hz]	3~ 400/50		Výparník	Pripojovacia dimenzia	1.1/4 "			
Prúd	nominálny [A]	5.58		Typ	BPHE			
	maximálny [A]	10.90		Počet	1			
	štartovací [A]	15.06		Materiál	AISI 316			
Softštartér	MCI 12		Maximálny prevádzkový tlak - chladivo [bar]			28		
Hlavný istič - charakteristika	C25		Teplonosné médium			Ethylenglykol		
Riadiaci systém			Konzentrácia soľanky [%]			29		
Hlavný regulátor	SIEMENS	RVS 21 AVS 55.199	Ochrana proti zamrznutiu do [°C]			-15		
Rozširovací modul	AVS75.391	AVS75.391	AVS75.3xx	Maximálny prevádzkový tlak - Ethylenglykol [bar]			6	
Bus Clip-In		LPB OCI345	Modbus OCI351	Objemový prietok - Ethylenglykol [m3/h]			3.44	
Online pripojenie		Web server OZW672	ToSyMo	Vnútorná tlaková strata - Ethylenglykol [kPa]			12	
			Teplotný spád - Ethylenglykol			3 K		
			ECM nízkoenergetické čerpadlo zdroj			UPMXL GEO 32-125		

*** s príslušenstvom

WAMAK BW 14 EVI

ErP (EU) No 811/2013: Technické parametre vykurovacích zariadení s tepelným čerpadlom

Model	BW 14 EVI
Tepelné čerpadlo vzduch-voda	nie
Tepelné čerpadlo soľanka-voda	áno
Tepelné čerpadlo voda-voda	nie
Nízkotepelné tepelné čerpadlo	nie
Vybavené prídavným ohrievačom	nie
Kombinované tepelné čerpadlo s ohrievačom	nie
Teplotné použitie	nízka teplota (35 °C - 30 °C)
Klimatická oblasť	priemerná

Položka	Symbol	Hodnota	mj	Položka	Symbol	Hodnota	mj
Menovitý tepelný výkon pri Tdesignh	Prated	14.5	kW	Sezónna energetická účinnosť vykurovania priestoru	η_s	211.4	%
Deklarovaný výkon vykurovania pri čiastočnom zaťažení pri vnútornej teplote 20 °C a vonkajšej teplote Tj				Deklarovaný súčiniteľ výkonu alebo pomer primárnej energie pre čiastočné zaťaženie pri vnútornej teplote 20 °C a vonkajšej teplote Tj			
Tj = -7 °C	Pdh	14.4	kW	Tj = -7 °C	COPd	4.74	-
Tj = +2 °C	Pdh	14.4	kW	Tj = +2 °C	COPd	5.2	-
Tj = +7 °C	Pdh	14.3	kW	Tj = +7 °C	COPd	5.6	-
Tj = +12 °C	Pdh	14.3	kW	Tj = +12 °C	COPd	6.1	-
Tj = bivalentná teplota	Pdh	14.5	kW	Tj = bivalentná teplota	COPd	4.6	-
Tj = hraničná prevádzková teplota	Pdh	---	kW	Tj = hraničná prevádzková teplota	COPd	---	-
Bivalentná teplota	Tbiv	-10	°C	Tj = hraničná prevádzková teplota	TOL	---	°C
Spotreba energie v iných ako aktívnych režimoch				Medzná prevádzková teplota vykurovacej vody	WTOL	65	°C
Vypnuté	Poff	0.010	kW	Prídavný ohrievač			
Režim vypnutia termostatu	Pto	0.010	kW	Menovitý tepelný výkon	Psup	2.8	kW
Pohotovostný režim	Psb	0.010	kW	Typ príkonu energie	elektrická		
Režim ohrevu kľukovej skrine	Pck	0.000	kW				
Ostatné položky							
Regulácia výkonu	pevná			Pre tepelné čerpadlá vzduch-voda: Menovitý prietok vzduchu, vonku	-	---	m ³ /h
Úroveň akustického výkonu							
v interiéri	Lwa	45	dB	Pre tepelné čerpadlá voda-voda alebo soľanka-voda: Menovitý prietok soľanky alebo vody, vonkajší výmenník tepla	-	3.44	m ³ /h
vonku	Lwa	---	dB				
Ročná spotreba energie	Q _{HE}	5627.5	kWh				

Kontaktné údaje: WAMAK, s.r.o., Orovnica 252, 96652, Orovnica, Slovakia, info@wamak.sk

WAMAK BW 14 EVI

ErP (EU) No 811/2013: Technické parametre vykurovacích zariadení s tepelným čerpadlom

Model	BW 14 EVI
Tepelné čerpadlo vzduch-voda	nie
Tepelné čerpadlo soľanka-voda	áno
Tepelné čerpadlo voda-voda	nie
Nízkotepelné tepelné čerpadlo	nie
Vybavené prídavným ohrievačom	nie
Kombinované tepelné čerpadlo s ohrievačom	nie
Teplotné použitie	stredá teplota (55°C - 47°C)
Klimatická oblasť	priemerná

Položka	Symbol	Hodnota	mj	Položka	Symbol	Hodnota	mj
Menovitý tepelný výkon pri Tdesignh	Prated	14.9	kW	Sezónna energetická účinnosť vykurovania priestoru	η_s	164.4	%
Deklarovaný výkon vykurovania pri čiastočnom zaťažení pri vnútornej teplote 20 °C a vonkajšej teplote Tj				Deklarovaný súčiniteľ výkonu alebo pomer primárnej energie pre čiastočné zaťaženie pri vnútornej teplote 20 °C a vonkajšej teplote Tj			
Tj = -7 °C	Pdh	14.9	kW	Tj = -7 °C	COPd	3.29	-
Tj = +2 °C	Pdh	14.9	kW	Tj = +2 °C	COPd	4.3	-
Tj = +7 °C	Pdh	14.6	kW	Tj = +7 °C	COPd	4.8	-
Tj = +12 °C	Pdh	14.6	kW	Tj = +12 °C	COPd	5.3	-
Tj = bivalentná teplota	Pdh	14.9	kW	Tj = bivalentná teplota	COPd	2.9	-
Tj = hraničná prevádzková teplota	Pdh	---	kW	Tj = hraničná prevádzková teplota	COPd	---	-
Bivalentná teplota	Tbiv	-10	°C	Tj = hraničná prevádzková teplota	TOL	---	°C
Spotreba energie v iných ako aktívnych režimoch				Medzná prevádzková teplota vykurovacej vody	WTOL	65	°C
Vypnuté	Poff	0.010	kW	Prídavný ohrievač			
Režim vypnutia termostatu	Pto	0.010	kW	Menovitý tepelný výkon	Psup	2.8	kW
Pohotovostný režim	Psb	0.010	kW	Typ príkonu energie	elektrická		
Režim ohrevu kľukovej skrine	Pck	0.000	kW				
Ostatné položky							
Regulácia výkonu	pevná			Pre tepelné čerpadlá vzduch-voda: Menovitý prietok vzduchu, vonku	-	---	m ³ /h
Úroveň akustického výkonu							
v interiéri	Lwa	45	dB	Pre tepelné čerpadlá voda-voda alebo soľanka-voda: Menovitý prietok soľanky alebo vody, vonkajší výmenník tepla	-	3.44	m ³ /h
vonku	Lwa	---	dB				
Ročná spotreba energie	Q _{HE}	7448.8	kWh				

Kontaktné údaje: WAMAK, s.r.o., Orovnica 252, 96652, Orovnica, Slovakia, info@wamak.sk



ENERG Y IIA
 енергия - ενεργεια IE IA

WAMAK

BW 14 EVI



55 °C

35 °C



A+++

A+++

45 dB
 --- dB

■ 16	■ 15
■ 15	■ 15
■ 15	■ 14
kW	kW

2019

811/2013

BW 14 EVI

ErP Data

	55 °C	35 °C
Energy class	A+++	A+++
η [%]	164.4	211.4
P_{rated} [kW]	15	15
Q_{HE} [kWh/y]	7449	5628
SCOP [-]	4.11	5.29
$T_{bivalent}$ [°C]	-10	-10

CONTROLLER



+ QAA55/75 class VII 3.5% ↓
 - QAA55/75 class III 1.5% ↓

Tepelný výkon - prevádzkové dáta

Version: v2024.004-BW-WW

Zdroj - soľanka [0°C] / Nízka teplota [35°C]

ZHI14K1P-TFM_R410A_1_BWW

Prevádzkový bod	Qh	P	COP
1 B0 / W30-35	14.5	3.1	4.63
2 B0 / W30-35 (MIN)	14.5	3.1	4.63
A B0 / Wxx-34	14.4	3.0	4.74
B B0 / Wxx-30	14.4	2.7	5.24
C B0 / Wxx-27	14.3	2.5	5.65
D B0 / Wxx-24	14.3	2.3	6.09
E B0 / Wxx-35	14.5	3.1	4.63
F B0 / Wxx-35	14.5	3.1	4.63

SCOP DATA EN 14825:2018	
Zdroj - soľanka [0°C] / Nízka teplota [35°C]	
SCOPon	5.32
SCOPnet	5.32
SCOP	5.29
η [%]	211.45
Label	A+++
Qh [kWh]	29957
Pdesignh [kW]	14.5
Tbivalent [°C]	-10

Zdroj - soľanka [0°C] / Stredná teplota [55°C]

Prevádzkový bod	Qh	P	COP
1 B0 / W47-55	14.9	5.2	2.88
2 B0 / W47-55 (MIN)	14.9	5.0	2.88
A B0 / Wxx-52	14.9	4.7	3.29
B B0 / Wxx-42	14.9	3.5	4.25
C B0 / Wxx-36	14.6	3.1	4.75
D B0 / Wxx-30	14.6	2.7	5.31
E B0 / Wxx-55	14.9	5.2	2.88
F B0 / Wxx-54	14.9	4.8	3.12

SCOP DATA EN 14825:2018	
Zdroj - soľanka [0°C] / Stredná teplota [55°C]	
SCOPon	4.13
SCOPnet	4.13
SCOP	4.11
η [%]	164.43
Label	A+++
Qh [kWh]	30783
Pdesignh [kW]	14.9
Tbivalent [°C]	-10

Zdroj - voda [10°C] / Nízka teplota [35°C]

Prevádzkový bod	Qh	P	COP
1 W10 / W30-35	18.4	3.0	6.08
2 W10 / W30-35 (MIN)	18.4	3.0	6.08
A W10 / Wxx-34	18.4	2.9	6.25
B W10 / Wxx-30	18.5	2.6	6.99
C W10 / Wxx-27	18.5	2.4	7.60
D W10 / Wxx-24	18.5	2.2	8.26
E W10 / Wxx-35	18.4	3.0	6.08
F W10 / Wxx-35	18.4	3.0	6.08

SCOP DATA EN 14825:2018	
Zdroj - voda [10°C] / Nízka teplota [35°C]	
SCOPon	7.11
SCOPnet	7.11
SCOP	7.06
η [%]	282.51
Label	A+++
Qh [kWh]	38014
Pdesignh [kW]	18.4
Tbivalent [°C]	-10.00

Zdroj - voda [10°C] / Stredná teplota [55°C]

	Prevádzkový bod	Qh	P	COP
1	W10 / W47-55	18.3	5.1	3.55
2	W10 / W47-55 (MIN)	18.3	5.1	3.55
A	W10 / Wxx-52	18.5	4.6	3.99
B	W10 / Wxx-42	18.6	3.5	5.37
C	W10 / Wxx-36	18.6	3.0	6.26
D	W10 / Wxx-30	18.7	2.6	7.09
E	W10 / Wxx-55	18.3	5.1	3.55
F	W10 / Wxx-55	18.3	5.1	3.55

SCOP DATA EN 14825:2018	
Zdroj - voda [10°C] / Stredná teplota [55°C]	
SCOPon	5.20
SCOPnet	5.20
SCOP	5.18
η [%]	207.03
Label	A+++
Qh [kWh]	37808
Pdesignh [kW]	18.3
Tbivalent [°C]	-10.00

Nízokteplotné chladenie W 12 / 7°C

	Prevádzkový bod	Qc	P	EER
A	W30-35 / W12-7	11.4	3.4	3.37
B	W26-xx / W12-7	11.6	3.0	3.81
C	W22-xx / W12-7	11.8	2.7	4.30
D	W18-xx / W12-7	11.9	2.6	4.57

SEER DATA EN 14825:2018 [W 12 / 7°C]	
SEERon	4.15
SEER	4.13
Qc [kWh]	6600
η [%]	165.35

Plošné chladenie W 23 / 18°C

	Prevádzkový bod	Qc	P	EER
A	W50-xx / W23-18	13.1	5.6	2.36
B	W40-xx / W23-18	14.3	4.3	3.29
C	W30-35 / W23-18	15.3	3.4	4.54
D	W26-xx / W23-18	15.7	3.0	5.14

SEER DATA EN 14825:2018 [W 23 / 18°C]	
SEERon	5.61
SEER	5.58
Qc [kWh]	6600
η [%]	223.30

Výkonové kryvky - vykurovanie

— Qh-nom-35
 - - - Qh-min-35
 - - - Qh-max-65
 — Qh-nom-45
 — Qh-nom-55
— Qh-nom-65

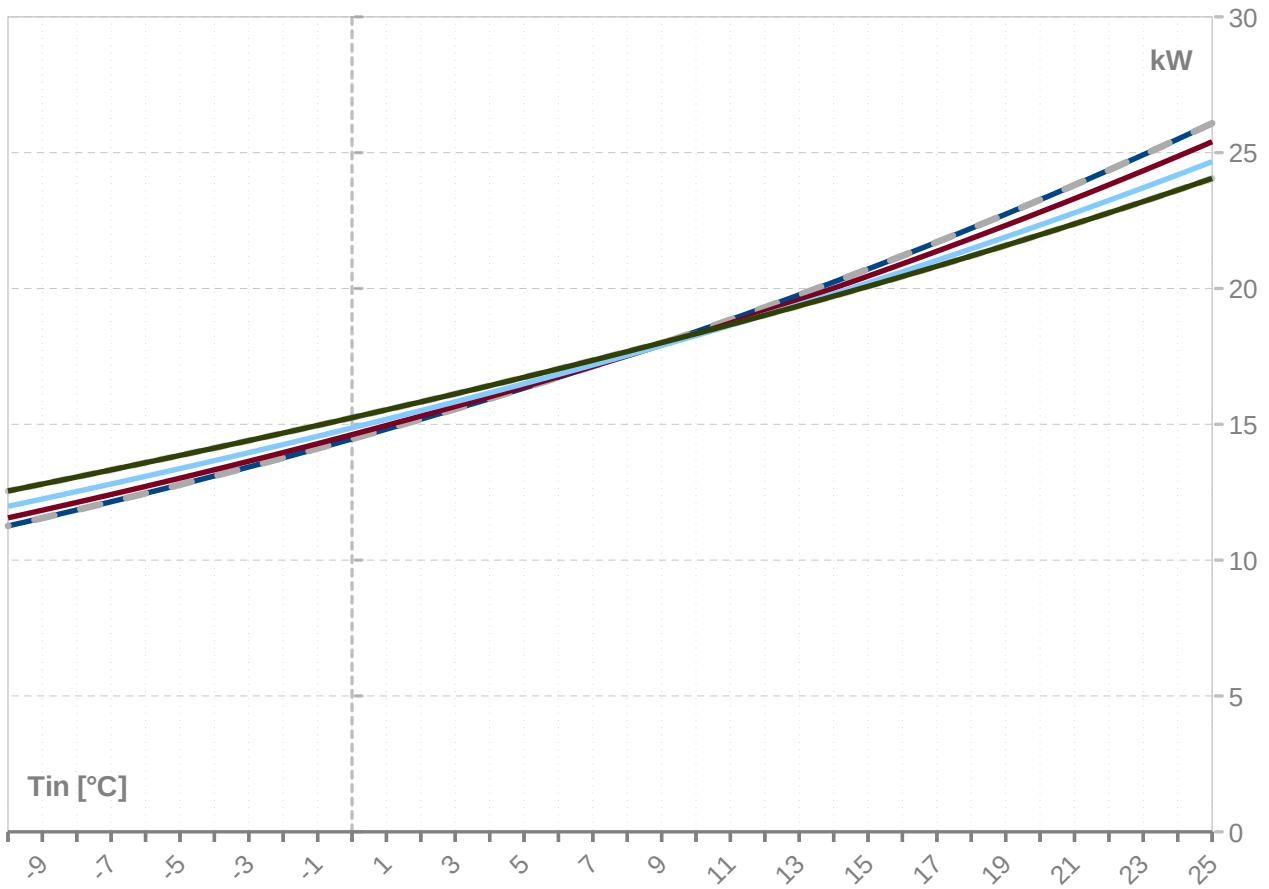

Výkonové kryvky - chladenie

— Qc-nom-12-7
 — Qc-nom-23-18

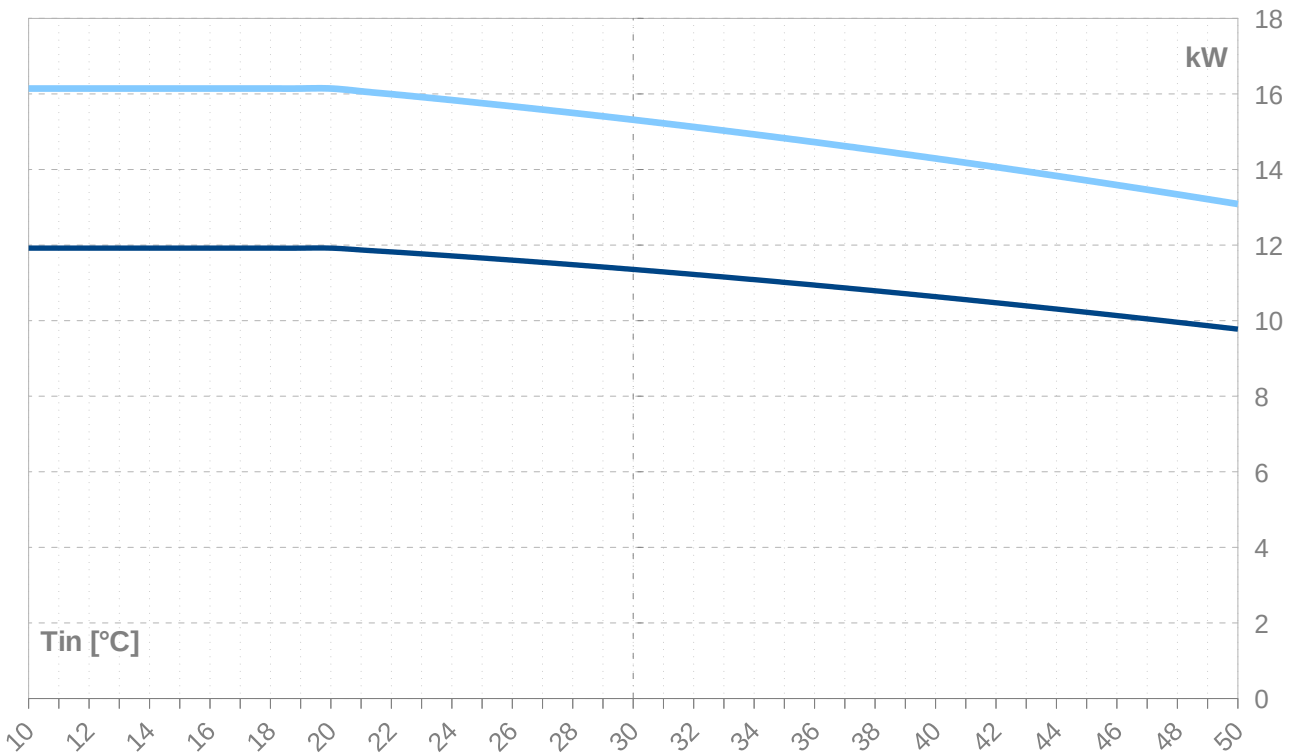

Tv -VY	35										
[°C]	Qh nom [kW]	Qh min [kW]	Qh max [kW]	Pin nom [kW]	Pin min [kW]	Pin max [kW]	COP nom kW / kW	Qc nom [kW]	Qc min [kW]	Qc max [kW]	I nom [A]
25	26.1	26.1	26.1	2.8	2.8	2.8	9.28	23.5	23.5	23.5	5.3
24	25.5	25.5	25.5	2.8	2.8	2.8	9.02	22.9	22.9	22.9	5.3
23	24.9	24.9	24.9	2.8	2.8	2.8	8.77	22.3	22.3	22.3	5.3
22	24.4	24.4	24.4	2.9	2.9	2.9	8.53	21.7	21.7	21.7	5.3
21	23.8	23.8	23.8	2.9	2.9	2.9	8.29	21.1	21.1	21.1	5.4
20	23.3	23.3	23.3	2.9	2.9	2.9	8.06	20.6	20.6	20.6	5.4
19	22.7	22.7	22.7	2.9	2.9	2.9	7.84	20.0	20.0	20.0	5.4
18	22.2	22.2	22.2	2.9	2.9	2.9	7.62	19.5	19.5	19.5	5.4
17	21.7	21.7	21.7	2.9	2.9	2.9	7.41	19.0	19.0	19.0	5.4
16	21.2	21.2	21.2	2.9	2.9	2.9	7.20	18.5	18.5	18.5	5.4
15	20.7	20.7	20.7	3.0	3.0	3.0	7.00	18.0	18.0	18.0	5.5
14	20.2	20.2	20.2	3.0	3.0	3.0	6.81	17.5	17.5	17.5	5.5
13	19.8	19.8	19.8	3.0	3.0	3.0	6.62	17.0	17.0	17.0	5.5
12	19.3	19.3	19.3	3.0	3.0	3.0	6.43	16.5	16.5	16.5	5.5
11	18.9	18.9	18.9	3.0	3.0	3.0	6.26	16.0	16.0	16.0	5.5
10	18.4	18.4	18.4	3.0	3.0	3.0	6.08	15.6	15.6	15.6	5.5
9	18.0	18.0	18.0	3.0	3.0	3.0	5.92	15.1	15.1	15.1	5.6
8	17.6	17.6	17.6	3.1	3.1	3.1	5.75	14.7	14.7	14.7	5.6
7	17.1	17.1	17.1	3.1	3.1	3.1	5.60	14.3	14.3	14.3	5.6
6	16.7	16.7	16.7	3.1	3.1	3.1	5.44	13.9	13.9	13.9	5.6
5	16.3	16.3	16.3	3.1	3.1	3.1	5.30	13.5	13.5	13.5	5.6
4	15.9	15.9	15.9	3.1	3.1	3.1	5.15	13.1	13.1	13.1	5.6
3	15.6	15.6	15.6	3.1	3.1	3.1	5.02	12.7	12.7	12.7	5.6
2	15.2	15.2	15.2	3.1	3.1	3.1	4.88	12.3	12.3	12.3	5.6
1	14.8	14.8	14.8	3.1	3.1	3.1	4.75	11.9	11.9	11.9	5.7
0	14.5	14.5	14.5	3.1	3.1	3.1	4.63	11.5	11.5	11.5	5.7
-1	14.1	14.1	14.1	3.1	3.1	3.1	4.51	11.2	11.2	11.2	5.7
-2	13.8	13.8	13.8	3.1	3.1	3.1	4.39	10.8	10.8	10.8	5.7
-3	13.4	13.4	13.4	3.1	3.1	3.1	4.27	10.5	10.5	10.5	5.7
-4	13.1	13.1	13.1	3.1	3.1	3.1	4.16	10.2	10.2	10.2	5.7
-5	12.8	12.8	12.8	3.1	3.1	3.1	4.06	9.8	9.8	9.8	5.7
-6	12.5	12.5	12.5	3.1	3.1	3.1	3.96	9.5	9.5	9.5	5.7
-7	12.1	12.1	12.1	3.1	3.1	3.1	3.86	9.2	9.2	9.2	5.7
-8	11.8	11.8	11.8	3.1	3.1	3.1	3.76	8.9	8.9	8.9	5.7
-9	11.5	11.5	11.5	3.1	3.1	3.1	3.67	8.6	8.6	8.6	5.7
-10	11.3	11.3	11.3	3.1	3.1	3.1	3.58	8.3	8.3	8.3	5.7
-11	11.0	11.0	11.0	3.1	3.1	3.1	3.49	8.0	8.0	8.0	5.7
-12	10.7	10.7	10.7	3.1	3.1	3.1	3.41	7.8	7.8	7.8	5.7
-13	10.4	10.4	10.4	3.1	3.1	3.1	3.33	7.5	7.5	7.5	5.7
-14	10.2	10.2	10.2	3.1	3.1	3.1	3.25	7.2	7.2	7.2	5.7
-15	9.9	9.9	9.9	3.1	3.1	3.1	3.18	7.0	7.0	7.0	5.7

-- pozor: pracovný rozsah nie je zohľadnený v tabuľke

ZHI14K1P-TFM_R410A_1_BWW

Tv -VY	45										
[°C]	Qh nom [kW]	Qh min [kW]	Qh max [kW]	Pin nom [kW]	Pin min [kW]	Pin max [kW]	COP nom kW / kW	Qc nom [kW]	Qc min [kW]	Qc max [kW]	I nom [A]
25	25.4	25.4	25.4	3.7	3.7	3.7	6.91	22.0	22.0	22.0	6.3
24	24.9	24.9	24.9	3.7	3.7	3.7	6.73	21.4	21.4	21.4	6.3
23	24.3	24.3	24.3	3.7	3.7	3.7	6.56	20.9	20.9	20.9	6.4
22	23.8	23.8	23.8	3.7	3.7	3.7	6.39	20.3	20.3	20.3	6.4
21	23.3	23.3	23.3	3.7	3.7	3.7	6.22	19.8	19.8	19.8	6.4
20	22.8	22.8	22.8	3.8	3.8	3.8	6.06	19.3	19.3	19.3	6.4
19	22.3	22.3	22.3	3.8	3.8	3.8	5.91	18.8	18.8	18.8	6.4
18	21.8	21.8	21.8	3.8	3.8	3.8	5.75	18.3	18.3	18.3	6.5
17	21.4	21.4	21.4	3.8	3.8	3.8	5.61	17.8	17.8	17.8	6.5
16	20.9	20.9	20.9	3.8	3.8	3.8	5.46	17.3	17.3	17.3	6.5
15	20.5	20.5	20.5	3.8	3.8	3.8	5.33	16.9	16.9	16.9	6.5
14	20.0	20.0	20.0	3.9	3.9	3.9	5.19	16.4	16.4	16.4	6.5
13	19.6	19.6	19.6	3.9	3.9	3.9	5.06	16.0	16.0	16.0	6.6
12	19.1	19.1	19.1	3.9	3.9	3.9	4.93	15.5	15.5	15.5	6.6
11	18.7	18.7	18.7	3.9	3.9	3.9	4.81	15.1	15.1	15.1	6.6
10	18.3	18.3	18.3	3.9	3.9	3.9	4.69	14.7	14.7	14.7	6.6
9	17.9	17.9	17.9	3.9	3.9	3.9	4.57	14.3	14.3	14.3	6.6
8	17.5	17.5	17.5	3.9	3.9	3.9	4.46	13.9	13.9	13.9	6.6
7	17.1	17.1	17.1	3.9	3.9	3.9	4.35	13.5	13.5	13.5	6.6
6	16.8	16.8	16.8	3.9	3.9	3.9	4.25	13.1	13.1	13.1	6.7
5	16.4	16.4	16.4	4.0	4.0	4.0	4.14	12.7	12.7	12.7	6.7
4	16.0	16.0	16.0	4.0	4.0	4.0	4.04	12.3	12.3	12.3	6.7
3	15.7	15.7	15.7	4.0	4.0	4.0	3.95	12.0	12.0	12.0	6.7
2	15.3	15.3	15.3	4.0	4.0	4.0	3.85	11.6	11.6	11.6	6.7
1	15.0	15.0	15.0	4.0	4.0	4.0	3.76	11.2	11.2	11.2	6.7
0	14.6	14.6	14.6	4.0	4.0	4.0	3.67	10.9	10.9	10.9	6.7
-1	14.3	14.3	14.3	4.0	4.0	4.0	3.59	10.6	10.6	10.6	6.7
-2	14.0	14.0	14.0	4.0	4.0	4.0	3.51	10.2	10.2	10.2	6.7
-3	13.6	13.6	13.6	4.0	4.0	4.0	3.43	9.9	9.9	9.9	6.7
-4	13.3	13.3	13.3	4.0	4.0	4.0	3.35	9.6	9.6	9.6	6.7
-5	13.0	13.0	13.0	4.0	4.0	4.0	3.27	9.3	9.3	9.3	6.7
-6	12.7	12.7	12.7	4.0	4.0	4.0	3.20	9.0	9.0	9.0	6.7
-7	12.4	12.4	12.4	4.0	4.0	4.0	3.13	8.7	8.7	8.7	6.7
-8	12.1	12.1	12.1	4.0	4.0	4.0	3.06	8.4	8.4	8.4	6.7
-9	11.8	11.8	11.8	4.0	4.0	4.0	2.99	8.1	8.1	8.1	6.7
-10	11.6	11.6	11.6	3.9	3.9	3.9	2.93	7.9	7.9	7.9	6.7
-11	11.3	11.3	11.3	3.9	3.9	3.9	2.87	7.6	7.6	7.6	6.6
-12	11.0	11.0	11.0	3.9	3.9	3.9	2.81	7.3	7.3	7.3	6.6
-13	10.7	10.7	10.7	3.9	3.9	3.9	2.75	7.1	7.1	7.1	6.6
-14	10.5	10.5	10.5	3.9	3.9	3.9	2.69	6.8	6.8	6.8	6.6
-15	10.2	10.2	10.2	3.9	3.9	3.9	2.64	6.6	6.6	6.6	6.6

-- pozor: pracovný rozsah nie je zohľadnený v tabuľke

Tv -VY		55										
Tz -VS [°C]	Qh nom [kW]	Qh min [kW]	Qh max [kW]	Pin nom [kW]	Pin min [kW]	Pin max [kW]	COP nom kW / kW	Qc nom [kW]	Qc min [kW]	Qc max [kW]	I nom [A]	
25	24.7	24.7	24.7	4.9	4.9	4.9	5.00	20.1	20.1	20.1	7.9	
24	24.2	24.2	24.2	5.0	5.0	5.0	4.88	19.6	19.6	19.6	8.0	
23	23.7	23.7	23.7	5.0	5.0	5.0	4.77	19.1	19.1	19.1	8.0	
22	23.2	23.2	23.2	5.0	5.0	5.0	4.66	18.6	18.6	18.6	8.0	
21	22.8	22.8	22.8	5.0	5.0	5.0	4.55	18.1	18.1	18.1	8.0	
20	22.3	22.3	22.3	5.0	5.0	5.0	4.45	17.6	17.6	17.6	8.1	
19	21.9	21.9	21.9	5.0	5.0	5.0	4.35	17.2	17.2	17.2	8.1	
18	21.5	21.5	21.5	5.1	5.1	5.1	4.25	16.7	16.7	16.7	8.1	
17	21.0	21.0	21.0	5.1	5.1	5.1	4.15	16.3	16.3	16.3	8.1	
16	20.6	20.6	20.6	5.1	5.1	5.1	4.06	15.9	15.9	15.9	8.1	
15	20.2	20.2	20.2	5.1	5.1	5.1	3.97	15.5	15.5	15.5	8.2	
14	19.8	19.8	19.8	5.1	5.1	5.1	3.88	15.0	15.0	15.0	8.2	
13	19.4	19.4	19.4	5.1	5.1	5.1	3.79	14.6	14.6	14.6	8.2	
12	19.0	19.0	19.0	5.1	5.1	5.1	3.71	14.2	14.2	14.2	8.2	
11	18.6	18.6	18.6	5.1	5.1	5.1	3.63	13.8	13.8	13.8	8.2	
10	18.3	18.3	18.3	5.1	5.1	5.1	3.55	13.5	13.5	13.5	8.2	
9	17.9	17.9	17.9	5.2	5.2	5.2	3.48	13.1	13.1	13.1	8.2	
8	17.5	17.5	17.5	5.2	5.2	5.2	3.40	12.7	12.7	12.7	8.2	
7	17.2	17.2	17.2	5.2	5.2	5.2	3.33	12.4	12.4	12.4	8.3	
6	16.8	16.8	16.8	5.2	5.2	5.2	3.26	12.0	12.0	12.0	8.3	
5	16.5	16.5	16.5	5.2	5.2	5.2	3.19	11.7	11.7	11.7	8.3	
4	16.2	16.2	16.2	5.2	5.2	5.2	3.13	11.3	11.3	11.3	8.3	
3	15.8	15.8	15.8	5.2	5.2	5.2	3.06	11.0	11.0	11.0	8.3	
2	15.5	15.5	15.5	5.2	5.2	5.2	3.00	10.7	10.7	10.7	8.3	
1	15.2	15.2	15.2	5.2	5.2	5.2	2.94	10.4	10.4	10.4	8.3	
0	14.9	14.9	14.9	5.2	5.2	5.2	2.88	10.0	10.0	10.0	8.3	
-1	14.6	14.6	14.6	5.2	5.2	5.2	2.82	9.7	9.7	9.7	8.3	
-2	14.3	14.3	14.3	5.2	5.2	5.2	2.77	9.4	9.4	9.4	8.2	
-3	14.0	14.0	14.0	5.1	5.1	5.1	2.71	9.2	9.2	9.2	8.2	
-4	13.7	13.7	13.7	5.1	5.1	5.1	2.66	8.9	8.9	8.9	8.2	
-5	13.4	13.4	13.4	5.1	5.1	5.1	2.61	8.6	8.6	8.6	8.2	
-6	13.1	13.1	13.1	5.1	5.1	5.1	2.56	8.3	8.3	8.3	8.2	
-7	12.8	12.8	12.8	5.1	5.1	5.1	2.51	8.0	8.0	8.0	8.2	
-8	12.5	12.5	12.5	5.1	5.1	5.1	2.46	7.8	7.8	7.8	8.2	
-9	12.2	12.2	12.2	5.1	5.1	5.1	2.42	7.5	7.5	7.5	8.1	
-10	12.0	12.0	12.0	5.0	5.0	5.0	2.37	7.3	7.3	7.3	8.1	
-11	11.7	11.7	11.7	5.0	5.0	5.0	2.33	7.0	7.0	7.0	8.1	
-12	11.4	11.4	11.4	5.0	5.0	5.0	2.29	6.8	6.8	6.8	8.0	
-13	11.2	11.2	11.2	5.0	5.0	5.0	2.25	6.5	6.5	6.5	8.0	
-14	10.9	10.9	10.9	4.9	4.9	4.9	2.21	6.3	6.3	6.3	8.0	
-15	10.7	10.7	10.7	4.9	4.9	4.9	2.17	6.1	6.1	6.1	7.9	

-- pozor: pracovný rozsah nie je zohľadnený v tabuľke

Tv -VY	65 (T-max)										
	[°C]	Qh nom [kW]	Qh min [kW]	Qh max [kW]	Pin nom [kW]	Pin min [kW]	Pin max [kW]	COP nom kW / kW	Qc nom [kW]	Qc min [kW]	Qc max [kW]
25	24.1	24.1	24.1	6.5	6.5	6.5	3.72	18.0	18.0	18.0	10.1
24	23.6	23.6	23.6	6.5	6.5	6.5	3.64	17.6	17.6	17.6	10.1
23	23.2	23.2	23.2	6.5	6.5	6.5	3.57	17.1	17.1	17.1	10.1
22	22.8	22.8	22.8	6.5	6.5	6.5	3.49	16.7	16.7	16.7	10.1
21	22.4	22.4	22.4	6.5	6.5	6.5	3.42	16.3	16.3	16.3	10.2
20	22.0	22.0	22.0	6.5	6.5	6.5	3.36	15.9	15.9	15.9	10.2
19	21.6	21.6	21.6	6.6	6.6	6.6	3.29	15.5	15.5	15.5	10.2
18	21.2	21.2	21.2	6.6	6.6	6.6	3.22	15.1	15.1	15.1	10.2
17	20.8	20.8	20.8	6.6	6.6	6.6	3.16	14.7	14.7	14.7	10.2
16	20.4	20.4	20.4	6.6	6.6	6.6	3.10	14.3	14.3	14.3	10.2
15	20.1	20.1	20.1	6.6	6.6	6.6	3.04	13.9	13.9	13.9	10.3
14	19.7	19.7	19.7	6.6	6.6	6.6	2.98	13.5	13.5	13.5	10.3
13	19.4	19.4	19.4	6.6	6.6	6.6	2.93	13.2	13.2	13.2	10.3
12	19.0	19.0	19.0	6.6	6.6	6.6	2.87	12.8	12.8	12.8	10.3
11	18.7	18.7	18.7	6.6	6.6	6.6	2.82	12.5	12.5	12.5	10.3
10	18.3	18.3	18.3	6.6	6.6	6.6	2.77	12.1	12.1	12.1	10.3
9	18.0	18.0	18.0	6.6	6.6	6.6	2.72	11.8	11.8	11.8	10.3
8	17.7	17.7	17.7	6.6	6.6	6.6	2.67	11.5	11.5	11.5	10.3
7	17.4	17.4	17.4	6.6	6.6	6.6	2.62	11.2	11.2	11.2	10.3
6	17.0	17.0	17.0	6.6	6.6	6.6	2.57	10.9	10.9	10.9	10.3
5	16.7	16.7	16.7	6.6	6.6	6.6	2.53	10.5	10.5	10.5	10.3
4	16.4	16.4	16.4	6.6	6.6	6.6	2.48	10.2	10.2	10.2	10.3
3	16.1	16.1	16.1	6.6	6.6	6.6	2.44	10.0	10.0	10.0	10.3
2	15.8	15.8	15.8	6.6	6.6	6.6	2.40	9.7	9.7	9.7	10.3
1	15.5	15.5	15.5	6.6	6.6	6.6	2.36	9.4	9.4	9.4	10.2
0	15.2	15.2	15.2	6.6	6.6	6.6	2.32	9.1	9.1	9.1	10.2
-1	15.0	15.0	15.0	6.6	6.6	6.6	2.28	8.8	8.8	8.8	10.2
-2	14.7	14.7	14.7	6.5	6.5	6.5	2.24	8.6	8.6	8.6	10.2
-3	14.4	14.4	14.4	6.5	6.5	6.5	2.20	8.3	8.3	8.3	10.2
-4	14.1	14.1	14.1	6.5	6.5	6.5	2.17	8.0	8.0	8.0	10.1
-5	13.9	13.9	13.9	6.5	6.5	6.5	2.13	7.8	7.8	7.8	10.1
-6	13.6	13.6	13.6	6.5	6.5	6.5	2.10	7.5	7.5	7.5	10.1
-7	13.3	13.3	13.3	6.4	6.4	6.4	2.07	7.3	7.3	7.3	10.0
-8	13.1	13.1	13.1	6.4	6.4	6.4	2.04	7.1	7.1	7.1	10.0
-9	12.8	12.8	12.8	6.4	6.4	6.4	2.00	6.8	6.8	6.8	10.0
-10	12.5	12.5	12.5	6.4	6.4	6.4	1.97	6.6	6.6	6.6	9.9
-11	12.3	12.3	12.3	6.3	6.3	6.3	1.94	6.4	6.4	6.4	9.9
-12	12.0	12.0	12.0	6.3	6.3	6.3	1.91	6.2	6.2	6.2	9.8
-13	11.8	11.8	11.8	6.3	6.3	6.3	1.89	5.9	5.9	5.9	9.8
-14	11.5	11.5	11.5	6.2	6.2	6.2	1.86	5.7	5.7	5.7	9.7
-15	11.3	11.3	11.3	6.2	6.2	6.2	1.83	5.5	5.5	5.5	9.7

-- pozor: pracovný rozsah nie je zohľadnený v tabuľke

Tch -VY		W 12 / 7 °C									
[°C]	Qc nom [kW]	Qc min [kW]	Qc max [kW]	Pin nom [kW]	Pin min [kW]	Pin max [kW]	EER kW / kW	Qh nom [kW]	Qh min [kW]	Qh max [kW]	I nom [A]
40	10.6	10.6	10.6	4.3	4.3	4.3	2.45	14.7	14.7	14.7	7.2
39	10.7	10.7	10.7	4.2	4.2	4.2	2.53	14.7	14.7	14.7	7.0
38	10.8	10.8	10.8	4.1	4.1	4.1	2.61	14.6	14.6	14.6	6.9
37	10.9	10.9	10.9	4.0	4.0	4.0	2.70	14.6	14.6	14.6	6.8
36	10.9	10.9	10.9	3.9	3.9	3.9	2.79	14.6	14.6	14.6	6.6
35	11.0	11.0	11.0	3.8	3.8	3.8	2.88	14.6	14.6	14.6	6.5
34	11.1	11.1	11.1	3.7	3.7	3.7	2.97	14.6	14.6	14.6	6.4
33	11.2	11.2	11.2	3.6	3.6	3.6	3.06	14.6	14.6	14.6	6.3
32	11.2	11.2	11.2	3.6	3.6	3.6	3.16	14.5	14.5	14.5	6.2
31	11.3	11.3	11.3	3.5	3.5	3.5	3.26	14.5	14.5	14.5	6.1
30	11.4	11.4	11.4	3.4	3.4	3.4	3.37	14.5	14.5	14.5	6.0
29	11.4	11.4	11.4	3.3	3.3	3.3	3.47	14.5	14.5	14.5	5.9
28	11.5	11.5	11.5	3.2	3.2	3.2	3.58	14.5	14.5	14.5	5.8
27	11.5	11.5	11.5	3.1	3.1	3.1	3.69	14.5	14.5	14.5	5.7
26	11.6	11.6	11.6	3.0	3.0	3.0	3.81	14.4	14.4	14.4	5.6
25	11.7	11.7	11.7	3.0	3.0	3.0	3.93	14.4	14.4	14.4	5.5
24	11.7	11.7	11.7	2.9	2.9	2.9	4.05	14.4	14.4	14.4	5.4
23	11.8	11.8	11.8	2.8	2.8	2.8	4.17	14.4	14.4	14.4	5.3
22	11.8	11.8	11.8	2.7	2.7	2.7	4.30	14.4	14.4	14.4	5.2
21	11.9	11.9	11.9	2.7	2.7	2.7	4.44	14.4	14.4	14.4	5.1
20	11.9	11.9	11.9	2.6	2.6	2.6	4.57	14.4	14.4	14.4	5.1

Tc [°C]		W 23 / 18 °C									
[°C]	Qc nom [kW]	Qc min [kW]	Qc max [kW]	Pin nom [kW]	Pin min [kW]	Pin max [kW]	EER kW / kW	Qh nom [kW]	Qh min [kW]	Qh max [kW]	I nom [A]
40	14.3	14.3	14.3	4.3	4.3	4.3	3.29	18.3	18.3	18.3	7.1
39	14.4	14.4	14.4	4.2	4.2	4.2	3.40	18.3	18.3	18.3	6.9
38	14.5	14.5	14.5	4.1	4.1	4.1	3.51	18.3	18.3	18.3	6.8
37	14.6	14.6	14.6	4.0	4.0	4.0	3.63	18.3	18.3	18.3	6.7
36	14.7	14.7	14.7	3.9	3.9	3.9	3.75	18.3	18.3	18.3	6.5
35	14.8	14.8	14.8	3.8	3.8	3.8	3.87	18.3	18.3	18.3	6.4
34	14.9	14.9	14.9	3.7	3.7	3.7	4.00	18.3	18.3	18.3	6.3
33	15.0	15.0	15.0	3.6	3.6	3.6	4.13	18.3	18.3	18.3	6.2
32	15.1	15.1	15.1	3.6	3.6	3.6	4.26	18.4	18.4	18.3	6.1
31	15.2	15.2	15.2	3.5	3.5	3.5	4.40	18.4	18.4	18.3	5.9
30	15.3	15.3	15.3	3.4	3.4	3.4	4.54	18.4	18.4	18.3	5.8
29	15.4	15.4	15.4	3.3	3.3	3.3	4.68	18.4	18.4	18.3	5.7
28	15.5	15.5	15.5	3.2	3.2	3.2	4.83	18.4	18.4	18.3	5.6
27	15.6	15.6	15.6	3.1	3.1	3.1	4.99	18.4	18.4	18.3	5.5
26	15.7	15.7	15.7	3.0	3.0	3.0	5.14	18.4	18.4	18.3	5.4
25	15.8	15.8	15.8	3.0	3.0	3.0	5.31	18.4	18.4	18.3	5.4
24	15.8	15.8	15.8	2.9	2.9	2.9	5.47	18.4	18.4	18.3	5.3
23	15.9	15.9	15.9	2.8	2.8	2.8	5.65	18.5	18.5	18.3	5.2
22	16.0	16.0	16.0	2.7	2.7	2.7	5.82	18.5	18.5	18.4	5.1
21	16.1	16.1	16.1	2.7	2.7	2.7	6.00	18.5	18.5	18.4	5.0
20	16.1	16.1	16.1	2.6	2.6	2.6	6.19	18.5	18.5	18.4	5.0

-- pozor: pracovný rozsah nie je zohľadnený v tabuľke

LEGENDA:

Tz-VS: Teplota zdroja - vstup [°C]

Tv-VY: Teplota vykurovania - výstup [°C]

Tch-VY: Teplota chladenia - výstup [°C]

Qh nom: Nominálny tepelný výkon

Qh min: Minimálny tepelný výkon

Qh max: Maxmálny tepelný výkon

Pin nom: Príkion pri nominálnom tepelnom výkone

Pin min: Príkion pri minimálnom tepelnom výkone

Pin max: Príkion pri maximálnom tepelnom výkone

COP nom: Koeficient účinnosti pri nominálnom tepelnom výkone

Qc nom: Chladiaci výkon / odobrané teplo pri nominálnom tepelnom výkone

Qc min: Chladiaci výkon / odobrané teplo pri minimálnom tepelnom výkone

Qc max: Chladiaci výkon / odobrané teplo pri maximálnom tepelnom výkone

I nom: Prúd pri nominálnom tepelnom výkone

EER: Koeficient účinnosti pri nominálnom chladiacom výkone

Prevádzkové Temp °C limity

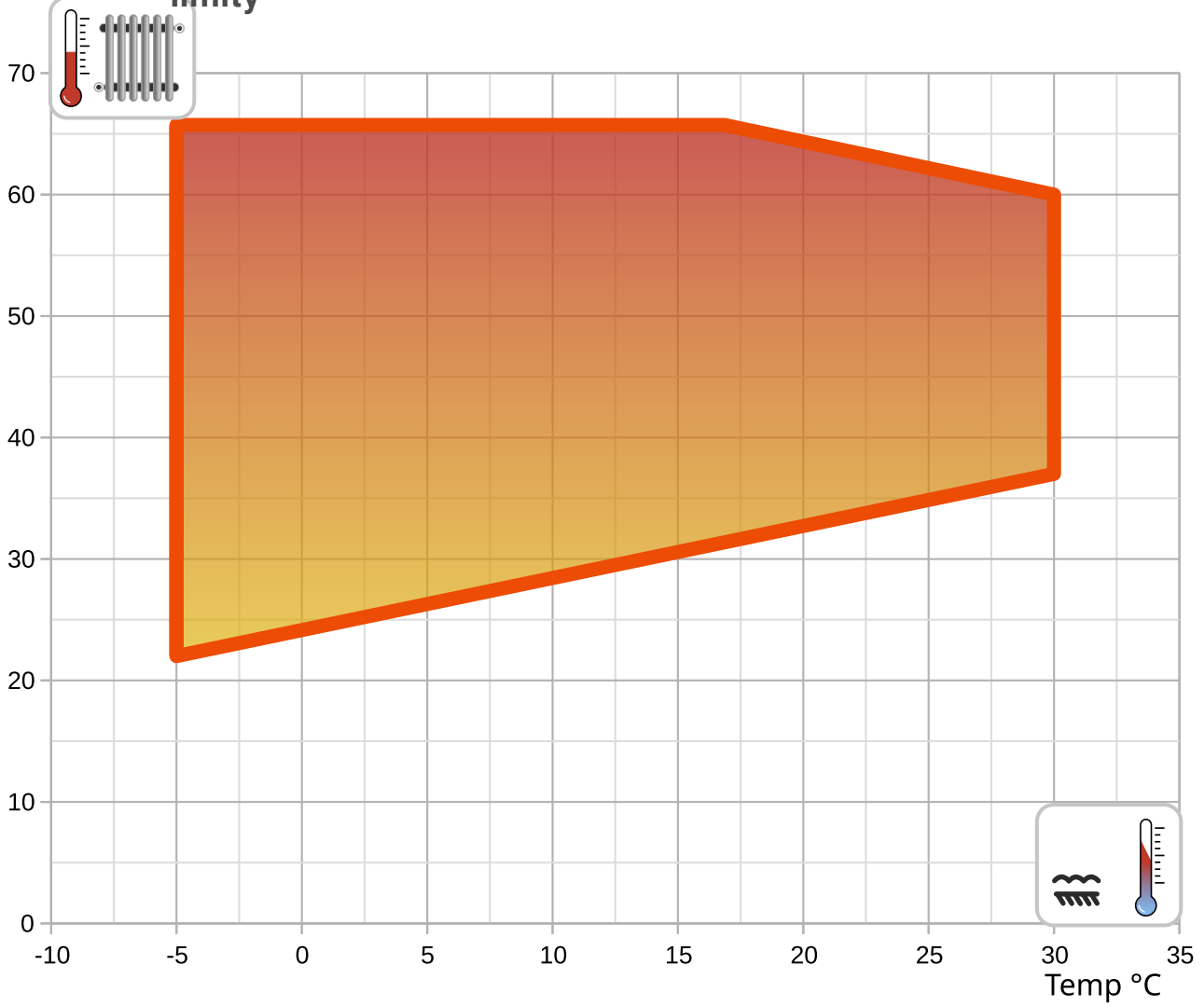

Temp °C

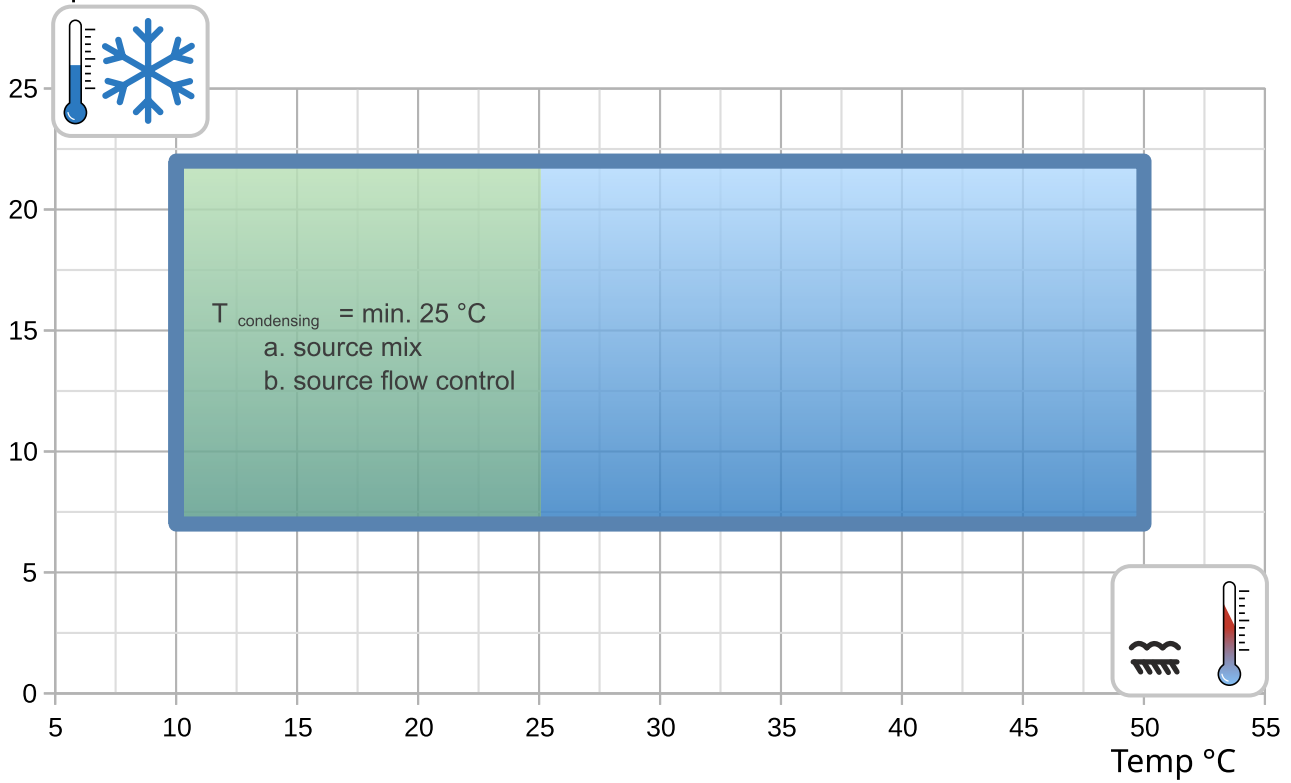

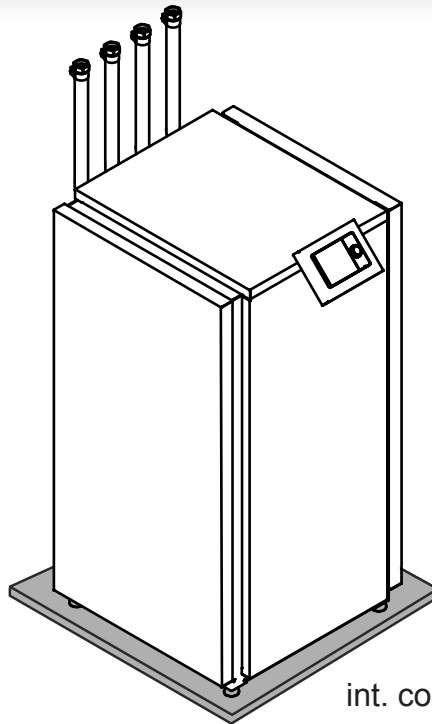
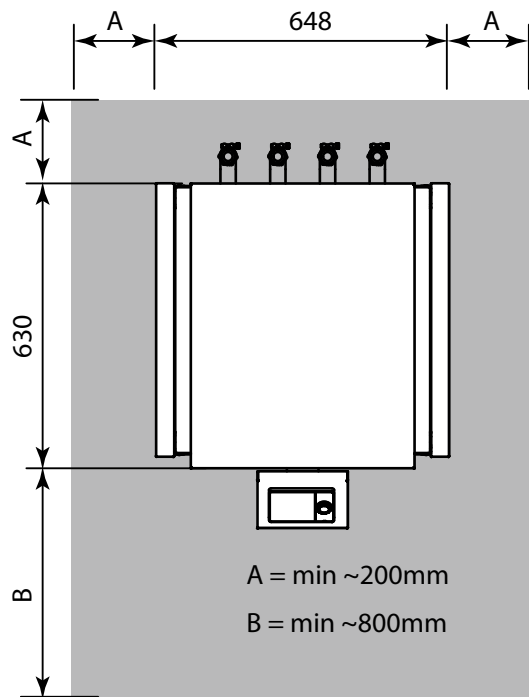
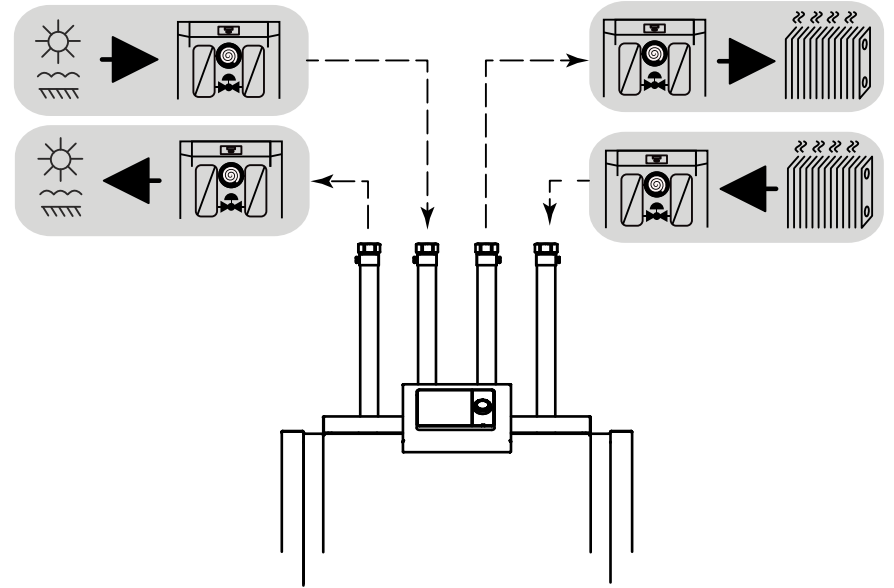
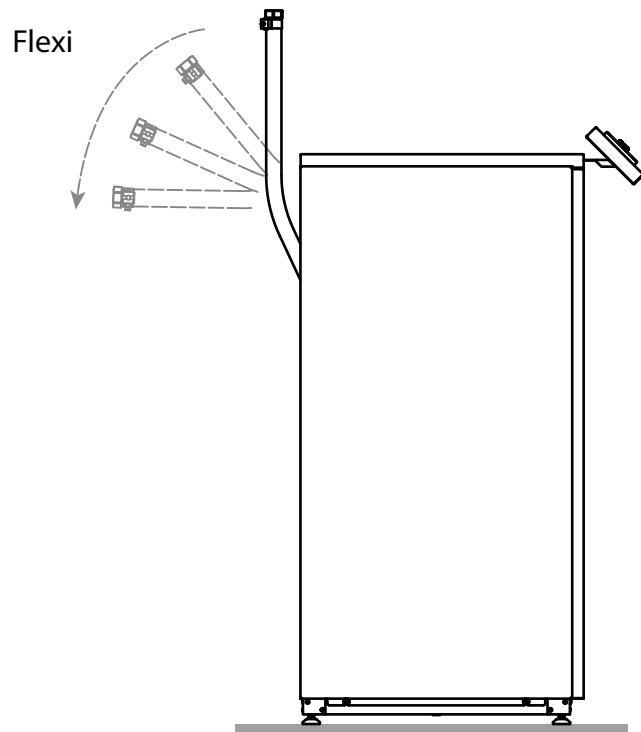
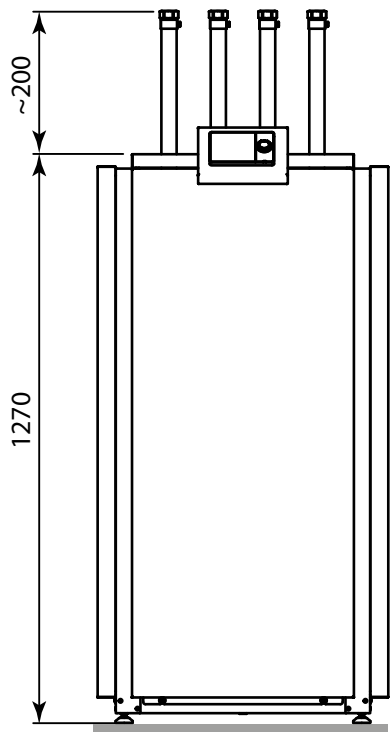

int. code: VN600

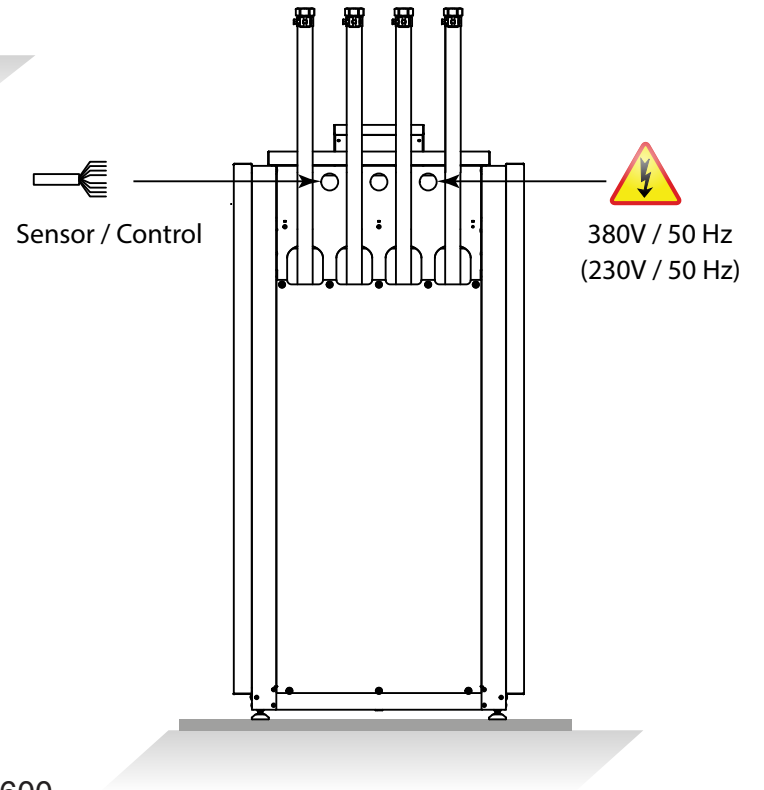

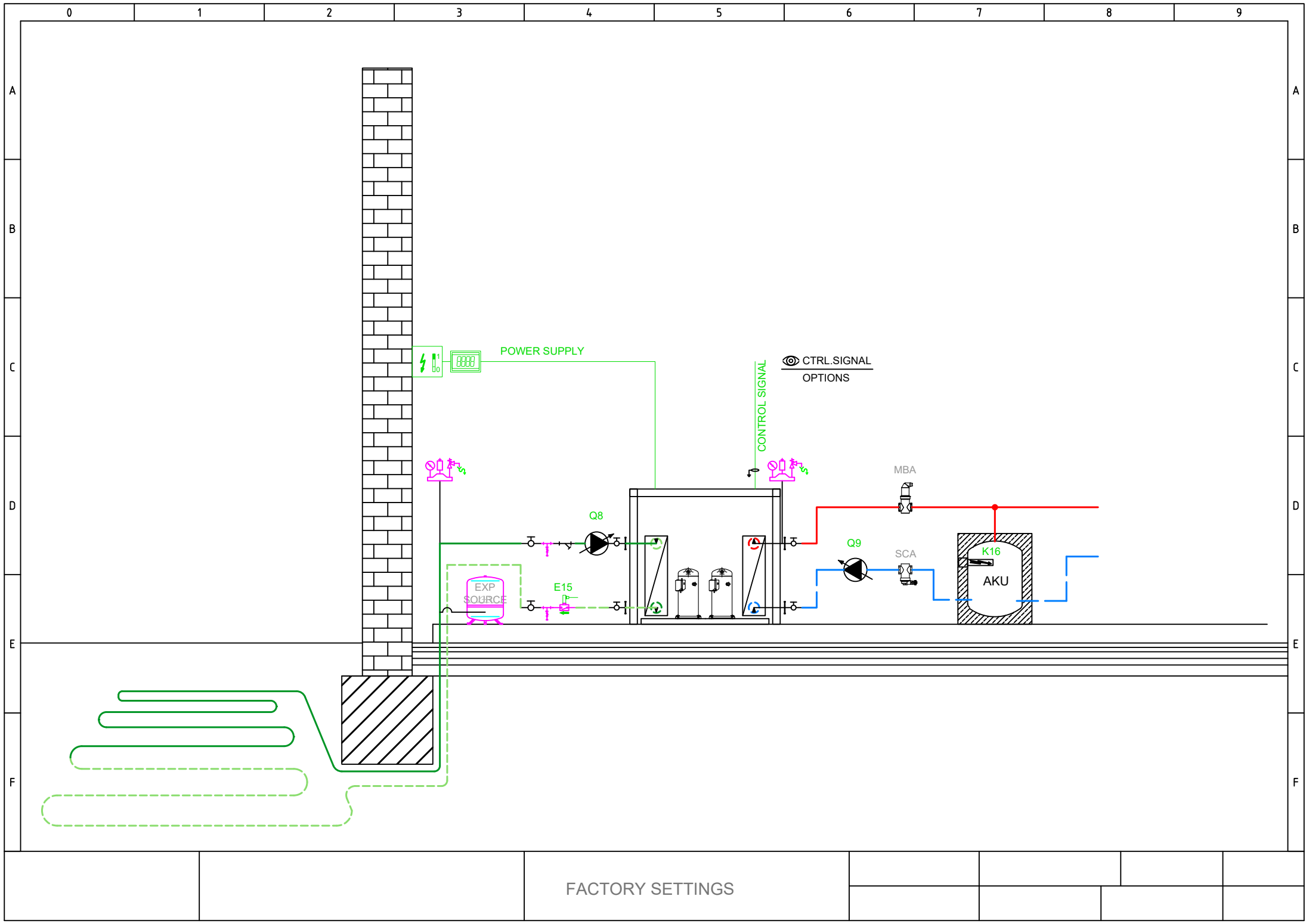

0

1

2

3

4

5

6

7

8

9

A

A

B

B

C

C

D

D

E

E

F

F



POWER SUPPLY

CONTROL SIGNAL

CTRL.SIGNAL
OPTIONSEXP
SOURCE

Q8

E15

MBA

Q9

SCA

K16

AKU

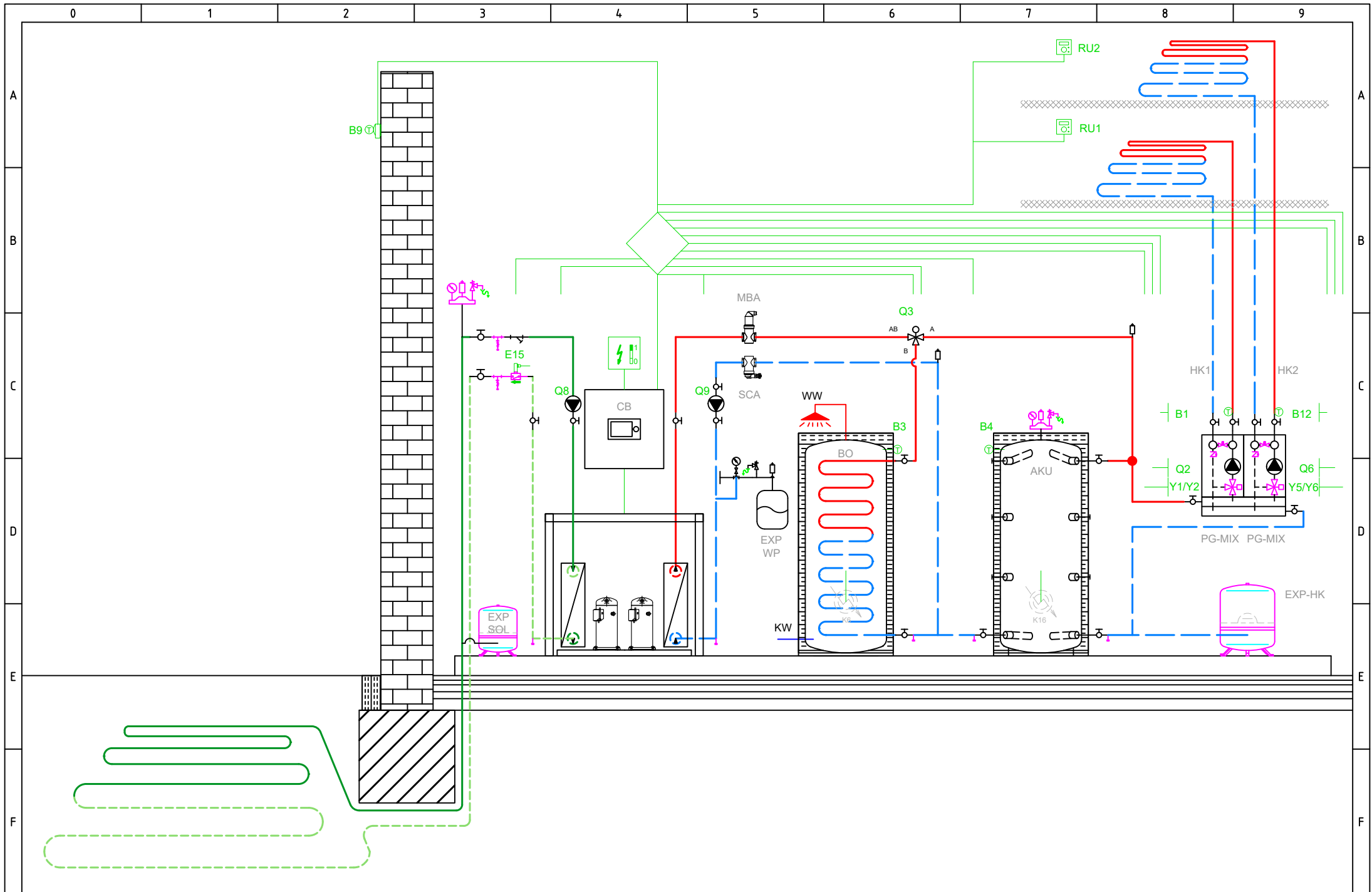

BASIC APPLICATION

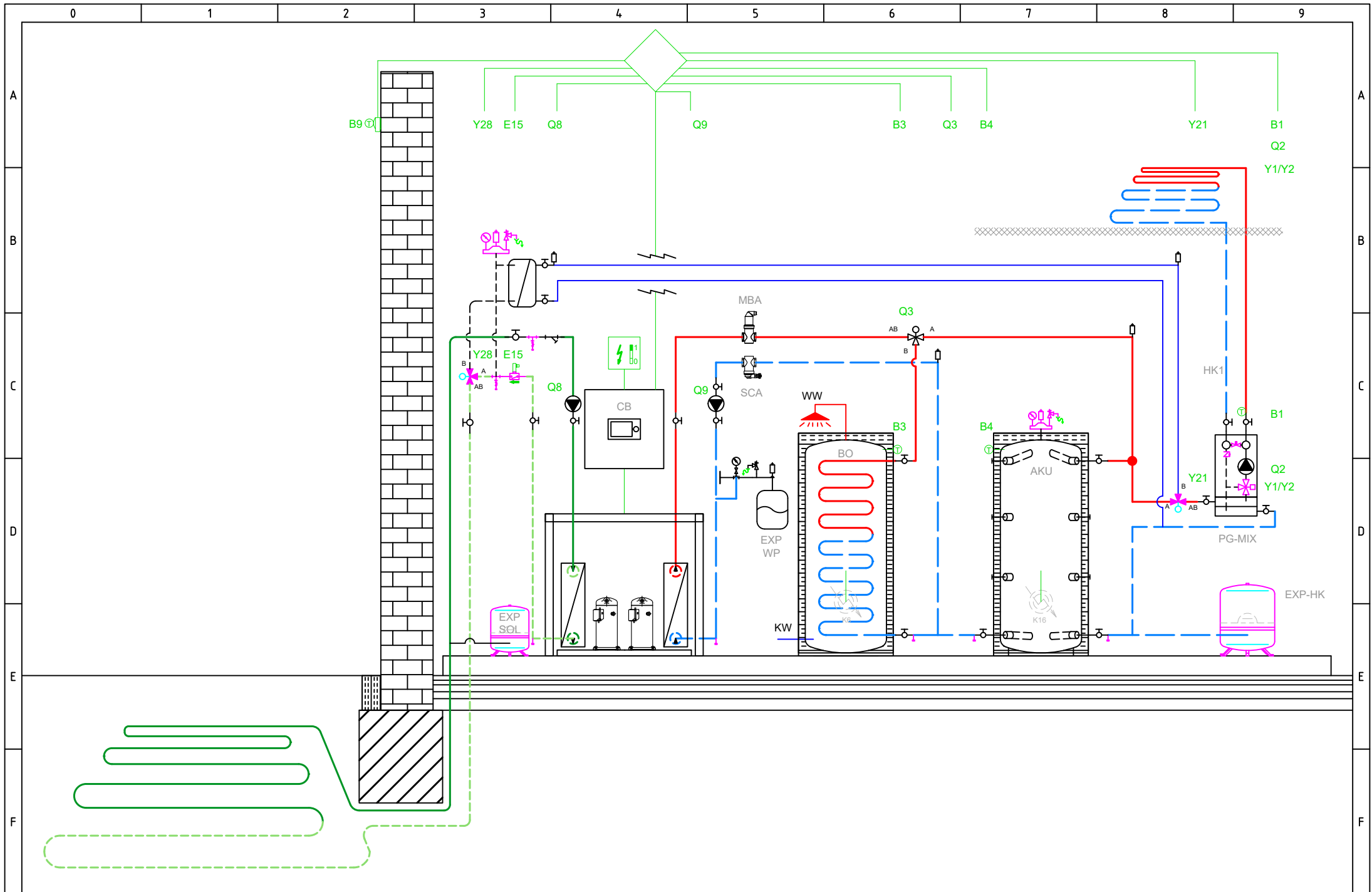

OPTIONAL APPLICATION

Total: max 6A
1 x QX...: max 2A

Hlavné napájanie 230V / 50 Hz
Uzemnenie
Nulový vodič

E9	Spínač nízkeho tlaku E9
E10	Spínač vysokého tlaku E10
E15	Spínač prietoku zdroja E15
E24	Spínač prietoku spotreby E24
E6	Blokovanie vys. tarifa el. E6
E12	Preťaženie kompresora 2 E12
E21	Sled fáz E21
E22	Sled fáz E22
E23	Sled fáz E23
E11	Preťaženie kompresora E11
K1	Kompresor I. stupeň K1

Q8 Čerpadlo zdroja Q8

Q9 Čerpadlo kondenzátora Q9

K10 Alarmový výstup K10

K40 Ohrev oleja K40

K81 Ventil výparníka K81

K82 Ventil EVI K82

K2 Kompresor 2. stupeň K2

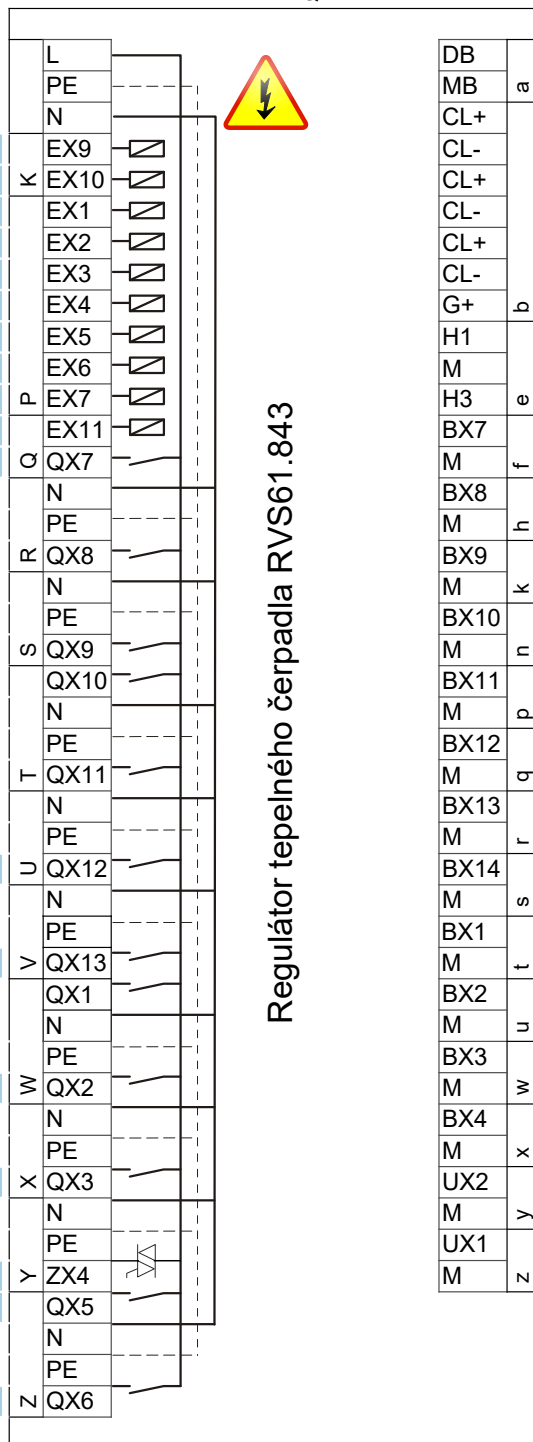

Regulátor tepelného čerpadla RVS61.843

DB	LPB Bus dáta
MB	LPB Bus zem
CL+	Izbový prístroj QAA...
CL-	Izbový prístroj QAA...
CL+	Izbový prístroj QAA... 2.
CL-	Izbový prístroj QAA... 2.
CL+	Izbový prístroj QAA... 3.
CL-	Izbový prístroj QAA... 3.
G+	12V napájanie → von
H1	
M	
H3	Požiadavka spotrebiča VK1
BX7	B81 Snímač horúcich plynov K1 B81
M	
BX8	
M	
BX9	
M	
BX10	B21 Snímač teploty výstupu TČ B21
M	
BX11	
M	
BX12	B71 Snímač teploty spiatocky TČ B71
M	
BX13	B91 Snímač vstupu zdroja B91
M	
BX14	B84 Snímač výstupu zdroja B92/B84
M	
BX1	
M	
BX2	
M	
BX3	B83 Snímač chladiaceho média B83
M	
BX4	B82 Snímač horúcich plynov K2 B82
M	
UX2	Čerpadlo kondenzátora Q9
M	0..10V analógový signál
UX1	Čerpadlo zdroja Q8
M	0..10V analógový signál



- AVS75.390
- AVS75.391
- AVS75.370

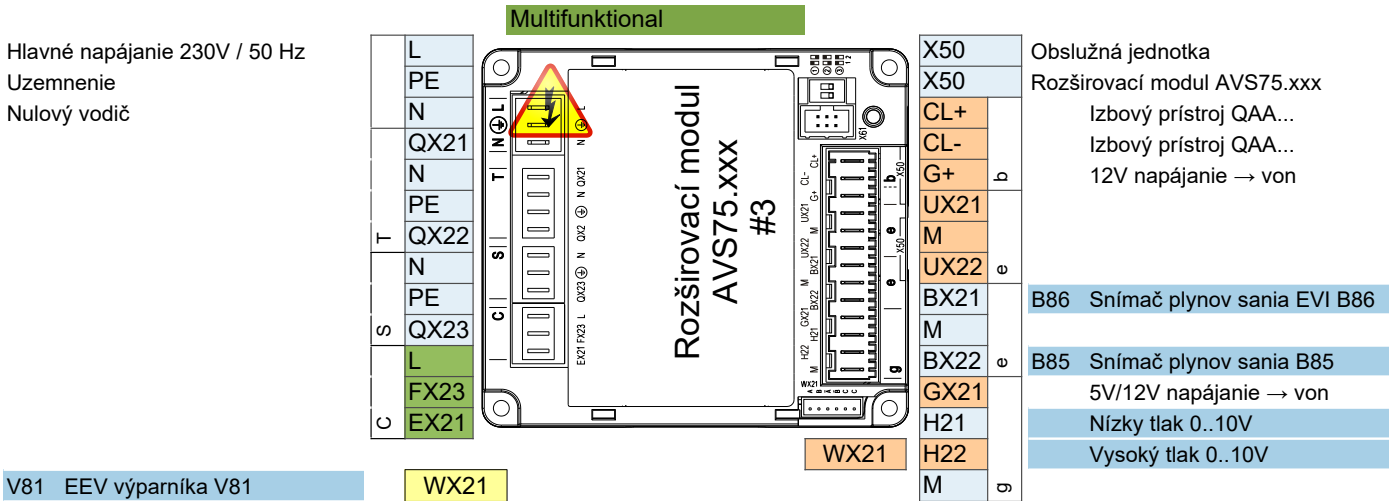
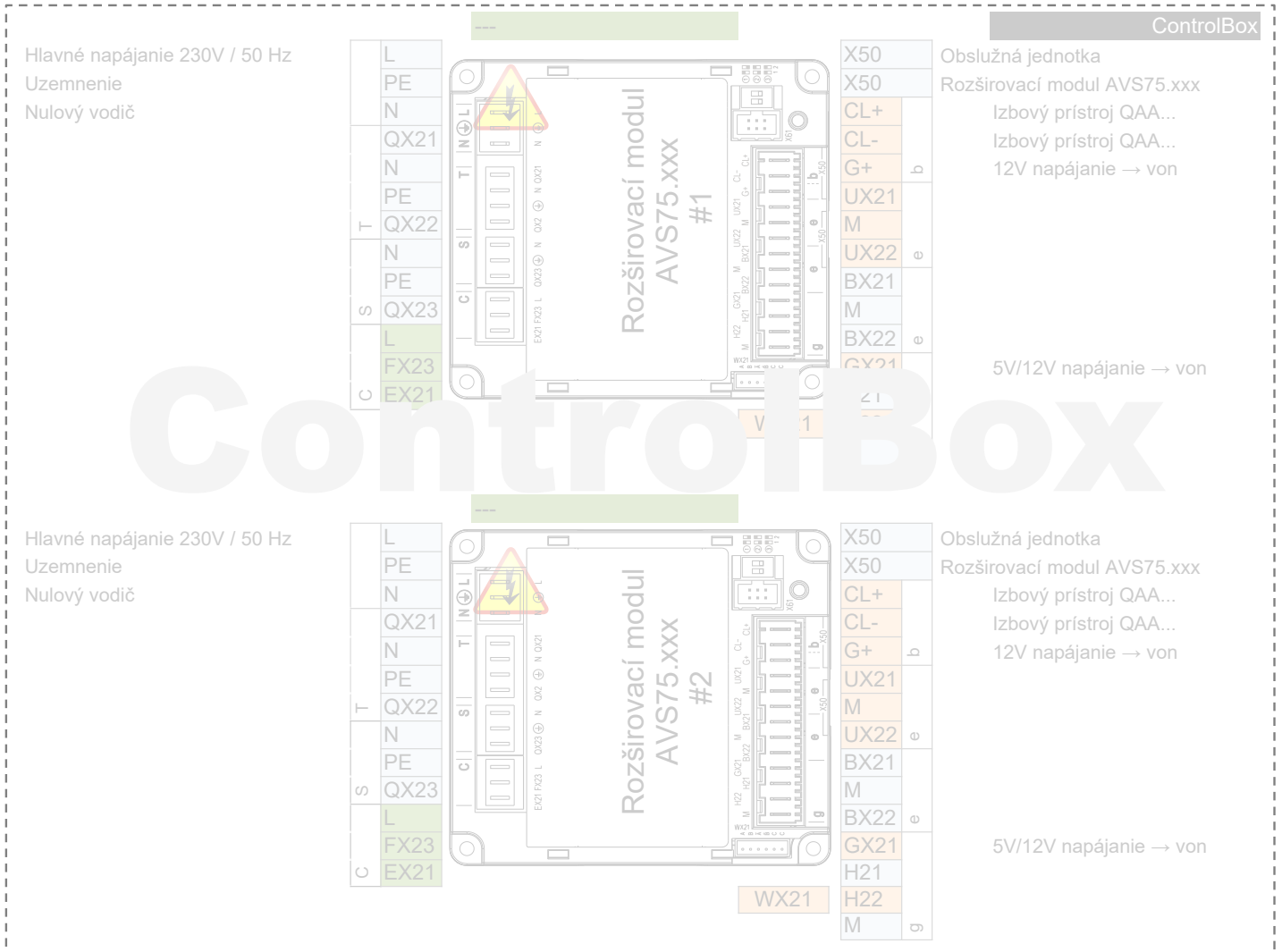

HEAT PUMP

EXTERNAL
INTERNAL

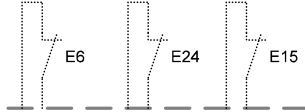

K1

K2

K82

K81

K40

K10

Q8 UX1

Q9 UX2

E11
KRW1
F1K
E11

E12
KRW2
F2K
E12

E6

Q9 ERR
F1S
E24

Q8 ERR
F1Z
E15

E10

E9

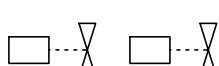

230V,50Hz max 6A

0...10V



DO



0...10V



DO



0...10V



DO



0...10V



DO



0...10V



DO



0...10V



DO



0...10V



DO



0...10V



DO



0...10V



DO



0...10V



DO



0...10V



DO



0...10V



DO

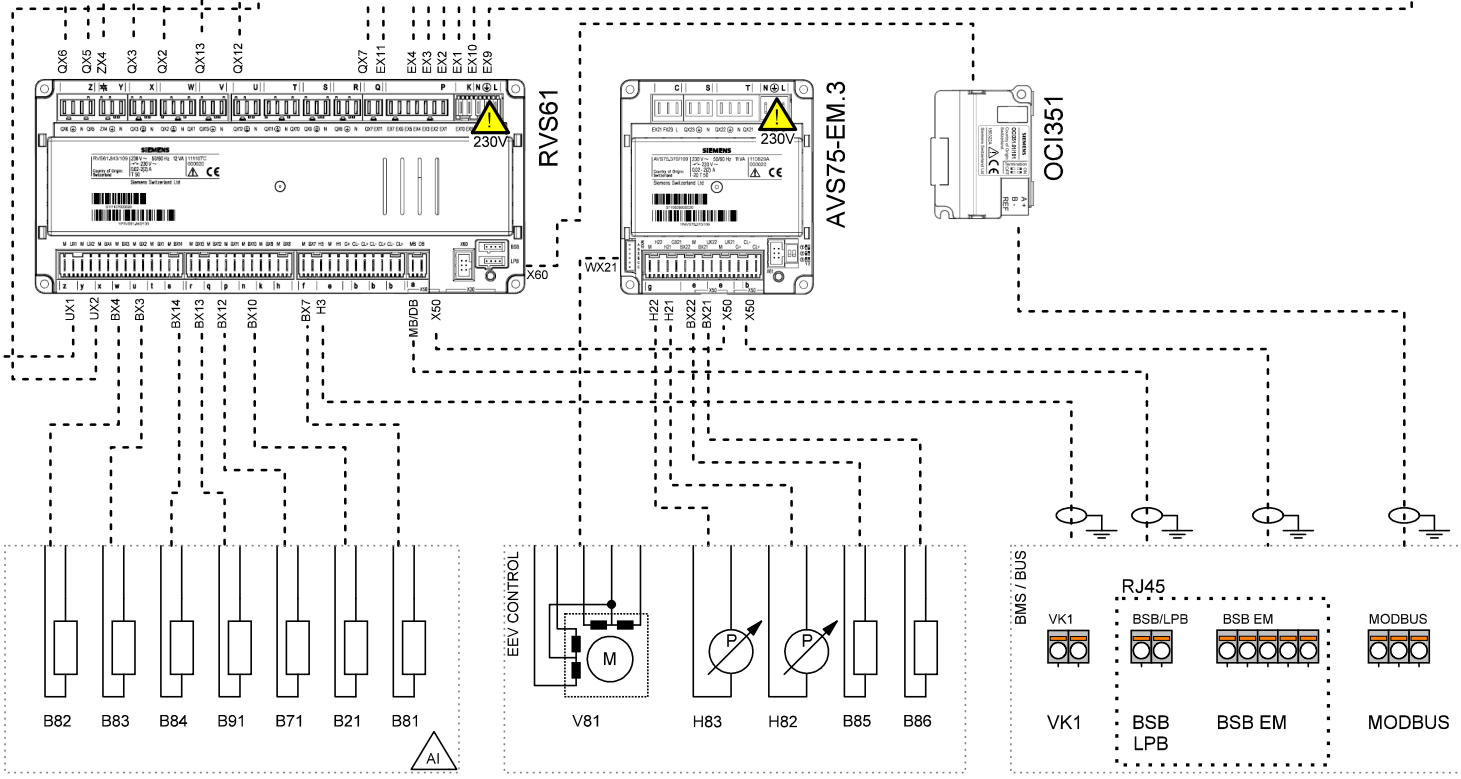
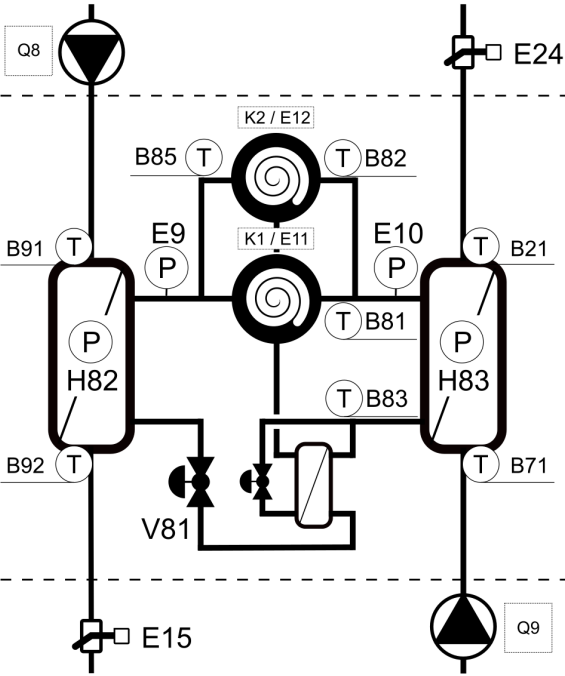

PWR SPLY: 3~ 400V, 50 Hz
CTRL: 1~ 230V, 50 HZ

Company

Title

Version / Note

Number

Created by

Date

Page

TBW-TWW

05/2024

1

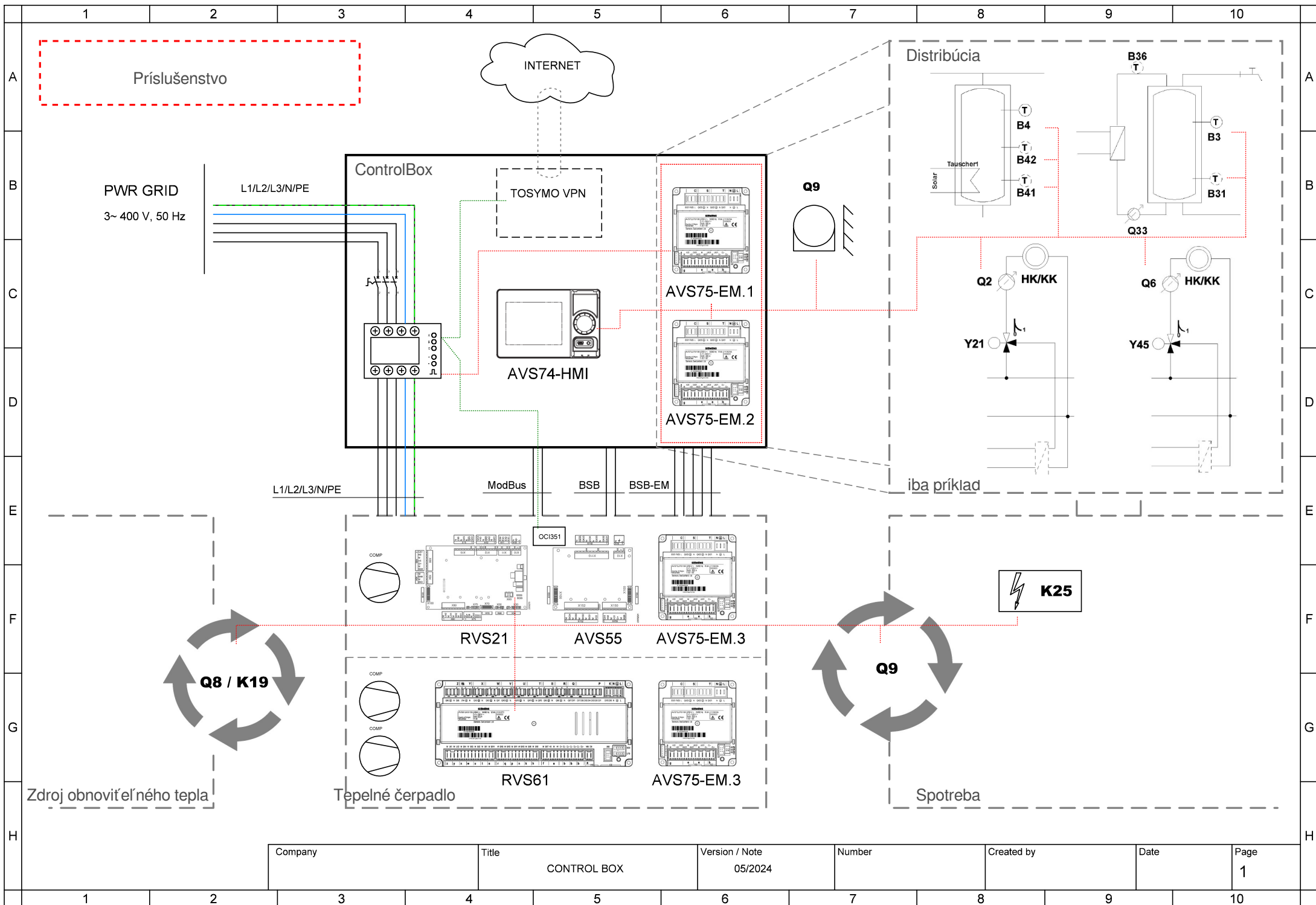

Company	Title	Version / Note	Number	Created by	Date	Page
	CONTROL BOX	05/2024				1



Company	Title	Version / Note	Number	Created by	Date	Page
	CONTROL BOX	05/2024				2



Company	Title	Version / Note	Number	Created by	Date	Page
	CONTROL BOX	05/2024				3



Company	Title	Version / Note	Number	Created by	Date	Page
	CONTROL BOX	05/2024				4

1 ControlBox

ControlBox s dvoma zabudovanými rozširujúcimi modulmi umožňuje početné možnosti ovládania aplikácie na strane spotrebiča za tepelným čerpadlom. Viac informácií nájdete v schéme ControlBoxu a v hárku s aplikačnými schémami.

2 Fixná žiadaná teplota výstupu - Zap / Vyp bezpotenciálny kontakt

2-vodičový tienený kábel 2 x 0,5 mm² - Nastavená hodnota = 45 °C (upraviteľné parametrom 1859)

Pripojovacia svorka - pozri schému zapojenia

3 Analógová regulácia žiadanej teploty výstupu 0..10V

2-vodičový tienený kábel 2 x 0,5 mm² - Nastavená hodnota: 0V = 16°C ~ 10V = 60°C (možnosť úpravy v nastavení parametrov)

Pripojovacia svorka - pozri schému zapojenia

4 ModBus RTU komunikačný príkaz

3 žilový tienený kábel min. 3 x 0,25 mm²

Pre tabuľku mapovania ModBus kontaktujte technickú podporu

5 MQTT IoT komunikačný protokol

Pre viac informácií kontaktujte technickú podporu