

Basic performance data - WAMAK AW 40 EVI

Heating - EN 14511		
Heating capacity [kW]	A7 / W35	42.8
	A2 / W35	36.2
	A-7 / W34	30.2
Electrical power input [kW]	A7 / W35	9.8
	A2 / W35	9.8
	A-7 / W34	9.5
Heating efficiency faktor [COP]	A7 / W35	4.37
	A2 / W35	3.71
	A-7 / W34	3.18
Seasonal space heating energy efficiency - SCOP EN 14825		
Average Climate / Low Temperature [35 °C]	SCOP	4.19
	η [%]	167.5
	Label	A+++
	Qhe [kWh]	16531.6
	Pdesignh [kW]	34.2
	Tbivalent [°C]	-7
Cooling		
Cooling capacity - [kW]	A35 / W23-18	42.7
	A25 / W23-18	44.9
	A35 / W12-7	31.4
	A25 / W12-7	31.4
Seasonal space cooling energy efficiency - SEER EN 14825		
[W 23 / 18 °C]	SEER	4.54
	Qce [kWh]	18840.0
	η_c [%]	181.5
Sound EN 12102		
Acoustic power - Lw	dB(A)	61.9
Acoustic pressure - Lp	1 m dB(A)	53.9
	5 m dB(A)	39.9
	10 m dB(A)	33.9
Mechanical and operational information		
Compressor type (3~ 400/50)	SCROLL / 1 /	On/Off
Refrigerant	R410A (GWP - 2088)	8.4 kg
Operating limit temperatures heating - (min / max) [°C]		25 / 65
Operating limit temperatures source - (min / max) [°C]		-22 / 40
Weight		260 kg

Main technical data - WAMAK AW 40 EVI

Enclosure type		VN800H		Heat energy rejection side data		
Basic dimensions	Height [mm]	1270		Operating limit temperatures heating	MAX [°C]	65
	Width [mm]	850			MIN [°C]	25
	Length [mm]	750		for more see operating limits diagram		
Weight [kg]	260		Condenser	Port size	2"	
Colour	Gray			Type	BPHE	
Enclosure IP Class	IP20			Count	1	
Refrigeration cycle				Material	AISI 316	
Compressor	Type	Scroll		Maximal operating pressure - refrigerant [bar]		50
	Number of stages	1		Maximal operating pressure - Water [bar]		6
	On/Off			Testing pressure [bar]		70
	Power factor Cosφ	0.59		Heat transfer medium		Water
	Winding resistance	0.83 Ohm		Volume flow @ dT 5K (nom) - Water [m3/h]		7.41
Refrigerant		R410A		Internal pressure drop - Water [kPa]		15
	Volme	8.4 kg		Temperature difference	@ 35°C (nom)	5 K
	GWP	2088			@ 55°C	8 K
	Safety class	A1			@ 65°C	10 K
Refrigeration oil type	POE RL32-3MAF		Renewable energy extraction side data			
	Oil volume	3.38 L		Operating limit temperatures source	MIN [°C]	-22
Maximal pressure - refrigerant [bar]	50		for more see operating limits diagram			
	PED class	2		Evaporator	MAX [°C]	40
EVI - vapour injection with economizer			Port size		5/8" - 1.1/8" "	
APS System of liquid subcooling			Type		Cu-coil /Al-fin	
Reversible operation (cooling)			Count		1	
Reverse defrosting with hot gas			Material	Cu/Al		
Plate exchanger protection HG-BYPASS			Maximal operating pressure - refrigerant [bar]		29	
Electrical connection data			Heat transfer medium		Air	
Line voltage [#~ V/Hz]	3~ 400/50		Volume flow - Air [m3/h]		13200	
Current	nominal [A]	21.79		Internal pressure drop - Air [kPa]		0.024
	maximal [A]	33.00		Temperature difference - Air		7 K
	starting [A]	50.47		Possible outdoor units	1 x VOV-900	
Softstart	-		1 x VOII-1200-2LOW			
Main safety	C40		1 x VOII-1200-2HIGH			
			1 x VOII-1200-2LOW-DUCT			
					1 x VOII-1200-2HIGH-DUCT	
Control System			Split System (compressor indoors)			
Main controller	SIEMENS	RVS 21 AVS 55.199		Liquid line dimension (up to 8 meters IU/OU)		5/8"
Extension module	AVS75.3xx	AVS75.3xx	AVS75.372	Suction line dimension (up to 8 meters IU/OU)		1.1/8"
Bus Clip-In		LPB OCI346	Modbus OCI352	Surcharge of refrigerant over 8 meter distance IU/OU		0.23 kg/m
Online connection		Web server OZW672	ToSyMo	air - water SPLIT heat pumps indoor units are delivered without full refrigerant charge only with residual overpressure from testing		
Superheat controller			SEC61			

*** with accessory

WAMAK AW 40 EVI

ErP (EU) No 811/2013: Technical parameters for heat pump space heaters

Model	AW 40 EVI
Air-to-water heat pump	yes
Brine-to-water heat pump	no
Water-to-water heat pump	no
Low-temperature heat pump	no
Equipped with a supplementary heater	no
Heat pump combination heater	no
Temperature application	low (35°C - 30°C)
Climate conditions	average

Item	Symbol	Value	Unit	Item	Symbol	Value	Unit
Rated heat output at Tdesignh	Prated	34.2	kW	Seasonal space heating energy efficiency	η_s	167.5	%
Declared capacity for heating for part load at indoor temperature 20 °C and outdoor temperature Tj				Declared coefficient of performance or primary energy ratio for part load at indoor temperature 20 °C and outdoor temperature Tj			
Tj = -7 °C	Pdh	30.2	kW	Tj = -7 °C	COPd	3.18	-
Tj = +2 °C	Pdh	36.1	kW	Tj = +2 °C	COPd	4.1	-
Tj = +7 °C	Pdh	42.8	kW	Tj = +7 °C	COPd	5.1	-
Tj = +12 °C	Pdh	50.6	kW	Tj = +12 °C	COPd	6.4	-
Tj = bivalent temperature	Pdh	29.7	kW	Tj = bivalent temperature	COPd	3.1	-
Tj = operation limit temperature	Pdh	21.5	kW	Tj = operation limit temperature	COPd	2.2	-
Bivalent temperature	Tbiv	-7	°C	Tj = operation limit temperature	TOL	-22	°C
Power consumption in modes other than active mode				Heating water operating limit temperature	WTOL	65	°C
Off mode	Poff	0.040	kW	Supplementary heater			
Thermostat-off mode	Pto	0.010	kW	Rated heat output	Psup	15.2	kW
Standby mode	Psb	0.010	kW	Type of energy input	electricity		
Crankcase heater mode	Pck	0.050	kW	For air-to-water heat pumps: Rated air flow rate, outdoors			
Other items				For water- or brine-to-water heat pumps: Rated brine or water flow rate, outdoor heat exchanger			
Capacity control		fixed				13200	m ³ /h
Sound power level						---	m ³ /h
indoors	Lwa	62	dB				
outdoors	Lwa	67	dB				
Annual energy consumption	Q _{HE}	16531.6	kWh				

Contact details: WAMAK, s.r.o., Orovnicna 252, 96652, Orovnicna, Slovakia, info@wamak.sk

WAMAK AW 40 EVI

ErP (EU) No 811/2013: Technical parameters for heat pump space heaters

Model	AW 40 EVI
Air-to-water heat pump	yes
Brine-to-water heat pump	no
Water-to-water heat pump	no
Low-temperature heat pump	no
Equipped with a supplementary heater	no
Heat pump combination heater	no
Temperature application	middle (55°C - 47°C)
Climate conditions	average

Item	Symbol	Value	Unit	Item	Symbol	Value	Unit
Rated heat output at Tdesignh	Prated	35.9	kW	Seasonal space heating energy efficiency	η_s	130.3	%
Declared capacity for heating for part load at indoor temperature 20 °C and outdoor temperature Tj				Declared coefficient of performance or primary energy ratio for part load at indoor temperature 20 °C and outdoor temperature Tj			
Tj = -7 °C	Pdh	31.4	kW	Tj = -7 °C	COPd	2.19	-
Tj = +2 °C	Pdh	36.4	kW	Tj = +2 °C	COPd	3.2	-
Tj = +7 °C	Pdh	42.8	kW	Tj = +7 °C	COPd	4.3	-
Tj = +12 °C	Pdh	50.5	kW	Tj = +12 °C	COPd	5.7	-
Tj = bivalent temperature	Pdh	31.1	kW	Tj = bivalent temperature	COPd	2.0	-
Tj = operation limit temperature	Pdh	23.3	kW	Tj = operation limit temperature	COPd	1.5	-
Bivalent temperature	Tbiv	-7	°C	Tj = operation limit temperature	TOL	-22	°C
Power consumption in modes other than active mode				Heating water operating limit temperature	WTOL	65	°C
Off mode	Poff	0.040	kW	Supplementary heater			
Thermostat-off mode	Pto	0.010	kW	Rated heat output	Psup	15.2	kW
Standby mode	Psb	0.010	kW	Type of energy input	electricity		
Crankcase heater mode	Pck	0.050	kW	For air-to-water heat pumps:			
Other items				Rated air flow rate, outdoors	-	13200	m ³ /h
Capacity control	fixed			For water- or brine-to-water heat pumps: Rated brine or water flow rate, outdoor heat exchanger			
Sound power level							
indoors	Lwa	62	dB				
outdoors	Lwa	67	dB				
Annual energy consumption	Q _{HE}	22420.8	kWh				

Contact details: WAMAK, s.r.o., Orovnicca 252, 96652, Orovnicca, Slovakia, info@wamak.sk



ENERG Y IIA
 енергия - ενεργεια IE IA



AW 40 EVI



55 °C

35 °C

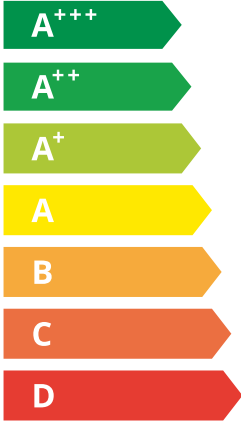

62 dB

67 dB

■ 38	■ 35
■ 36	■ 35
■ 36	■ 33
kW	kW

2019

811/2013

AW 40 EVI

ErP Data

	55 °C	35 °C
Energy class	A++	A+++
η [%]	130.3	167.5
P_{rated} [kW]	36	35
Q_{HE} [kWh/y]	22421	16532
SCOP [-]	3.26	4.19
$T_{bivalent}$ [°C]	-7	-7

CONTROLLER



+ QAA55/75 class VII 3.5% ↓
 - QAA55/75 class III 1.5% ↓

Heating performance data

Version: v2024.010-AW

Average Climate / Low Temperature [35°C]

ZHI40K1P-TFD_R410A_1_AW

Operating conditions		Qh	P	COP
1	A7 / W30-35	42.8	9.8	4.37
2	A2 / W35	36.2	9.8	3.71
3	A-22 / W35	21.5	9.7	2.22
A	A-7 / W34	30.2	9.5	3.18
B	A2 / W30	36.1	8.8	4.10
C	A7 / W27	42.8	8.3	5.13
D	A12 / W24	50.6	7.9	6.40
E	A-10 / W35	29.7	9.7	3.05
F	A-7 / W34	30.2	9.5	3.18

SCOP DATA EN 14825:2018	
Average Climate / Low Temperature [35°C]	
SCOPon	4.27
SCOPnet	4.31
SCOP	4.19
η [%]	167.47
Label	A+++
Qh [kWh]	16531.64
Pdesignh [kW]	34.2
Tbivalent [°C]	-7.00

Average Climate / Medium Temperature [55°C]

Operating conditions		Qh	P	COP
1	A7 / W47-55	43.5	15.5	2.81
2	A2 / W55	37.3	15.4	2.42
3	A-22 / W55	23.3	14.3	1.51
A	A-7 / W52	31.4	14.3	2.19
B	A2 / W42	36.4	11.3	3.20
C	A7 / W36	42.8	10.0	4.28
D	A12 / W30	50.5	8.9	5.67
E	A-10 / W55	31.1	15.4	2.02
F	A-7 / W55	31.7	15.4	2.06

SCOP DATA EN 14825:2018	
Average Climate / Medium Temperature [55°C]	
SCOPon	3.31
SCOPnet	3.33
SCOP	3.26
η [%]	130.31
Label	A++
Qh [kWh]	22420.81
Pdesignh [kW]	35.9
Tbivalent [°C]	-7.00

Cooling performance data

Low temperature cooling W 12 / 7°C

Operating conditions		Qc	P	EER
A	A35 / W12-7	31.4	11.7	2.70
B	A30 / W12-7	32.4	10.4	3.11
C	A25 / W12-7	33.3	9.4	3.54
D	A20 / W12-7	34.1	8.5	4.01

SEER DATA EN 14825:2018 [W 12 / 7°C]	
SEERon	3.46
SEER	3.39
Qc [kWh]	6859.80
η [%]	135.57

Radiant cooling W 23 / 18°C

Operating conditions		Qc	P	EER
A	A35 / W23-18	42.7	11.7	3.66
B	A30 / W23-18	43.8	9.8	4.20
C	A25 / W23-18	44.9	8.8	4.77
D	A20 / W23-18	45.8	8.0	5.39

SEER DATA EN 14825:2018 [W 23 / 18°C]	
SEERon	4.66
SEER	4.54
Qc [kWh]	5088.13
η [%]	181.54

Performance lines - heating

- Qh-nom-35 — Qh-min-35 - - - Qh-max-65 — Qh-nom-45 — Qh-nom-55
- Qh-nom-65 — Pratedh-35 — Pratedh-55

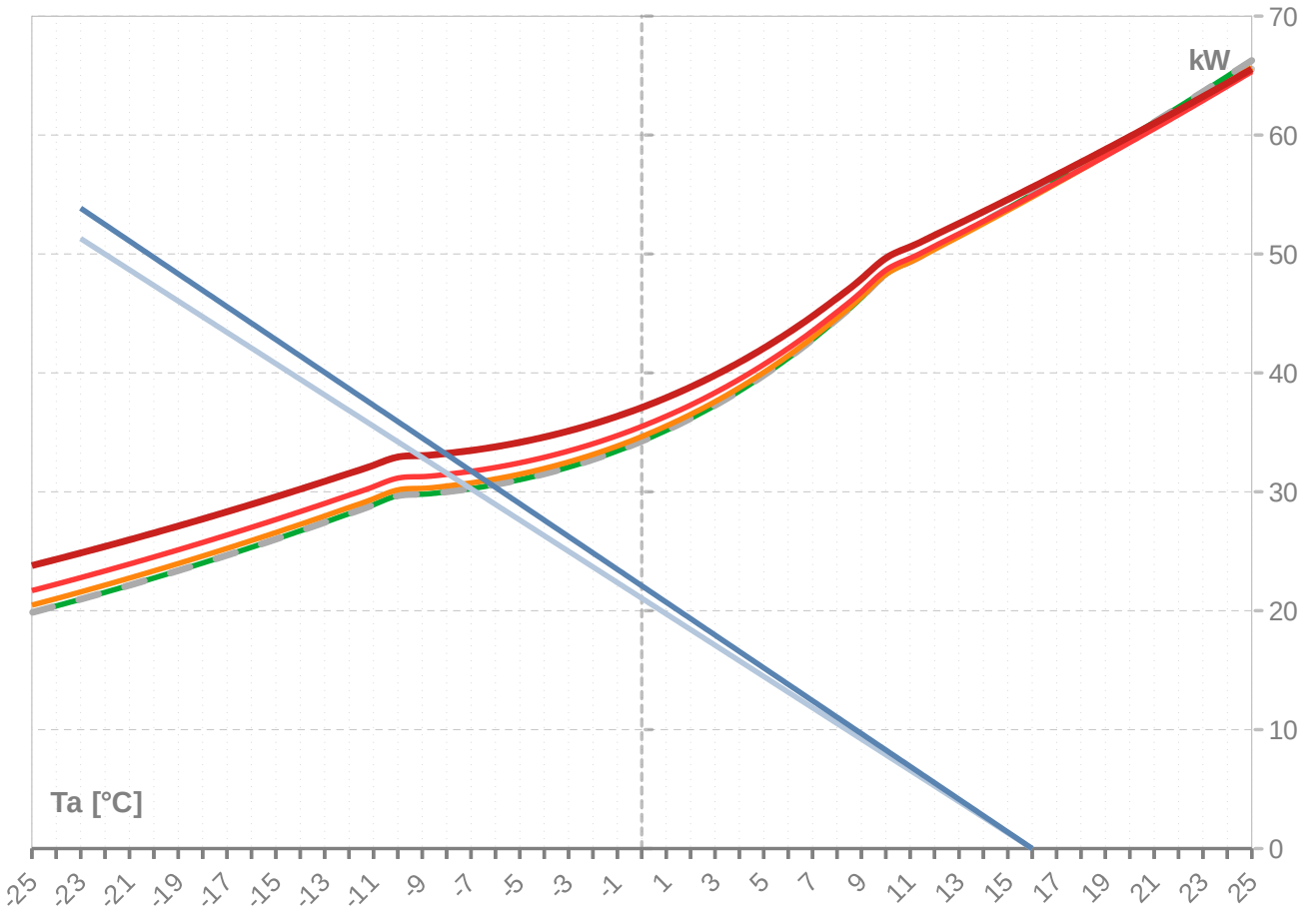

Performance lines - cooling

- Pratedc — Qc-12/7 — Qc-23/18

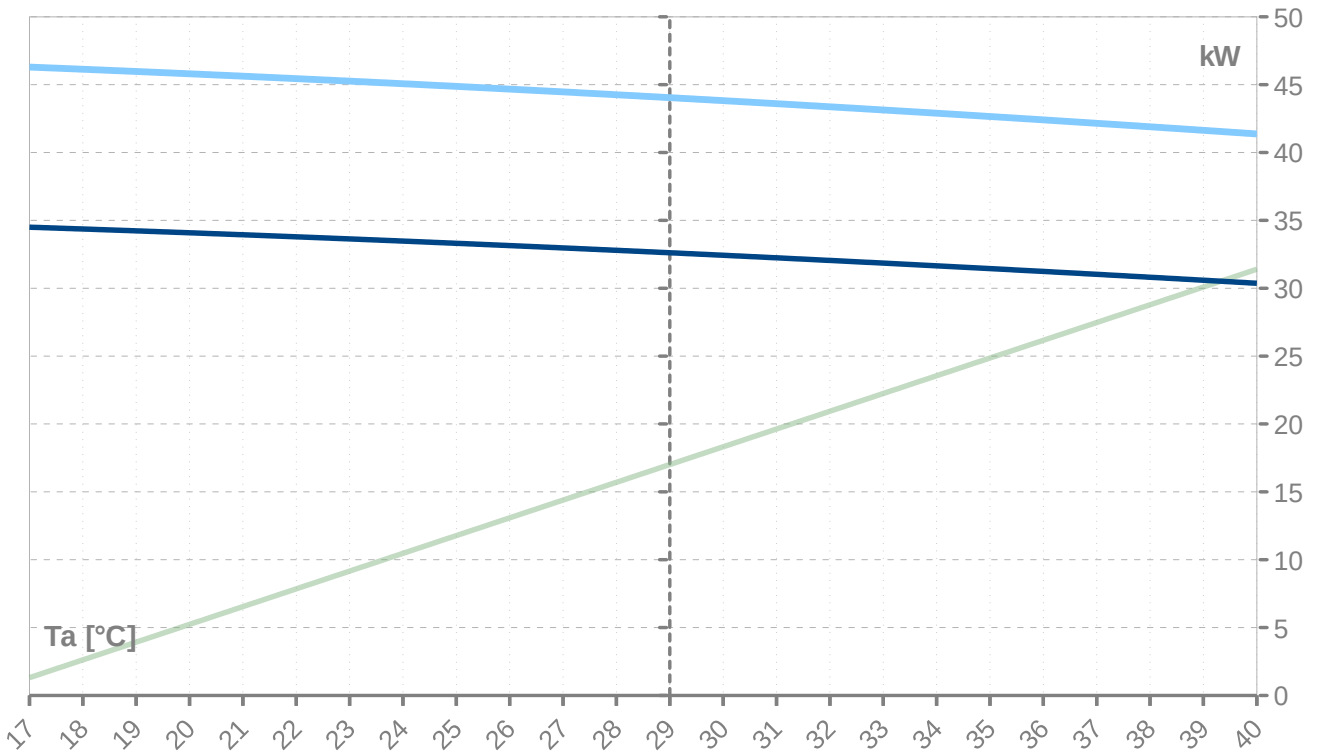

Th [°C]		35 °C								
Ta [°C]	Qh nom [kW]	Qh min [kW]	Qh max [kW]	Pin nom [kW]	Pin-min [kW]	Pin-max [kW]	COP kW / kW	I nom [A]	I min [A]	I max [A]
25	56.2	56.2		9.9	9.9		5.67	21.7	21.7	
24	56.2	56.2		9.9	9.9		5.67	21.7	21.7	
23	56.2	56.2		9.9	9.9		5.67	21.7	21.7	
22	56.2	56.2		9.9	9.9		5.67	21.7	21.7	
21	56.2	56.2		9.9	9.9		5.67	21.7	21.7	
20	56.2	56.2		9.9	9.9		5.67	21.7	21.7	
19	56.2	56.2		9.9	9.9		5.67	21.7	21.7	
18	56.2	56.2		9.9	9.9		5.67	21.7	21.7	
17	56.2	56.2		9.9	9.9		5.67	21.7	21.7	
16	55.0	55.0	55.0	9.9	9.9	9.9	5.55	21.7	21.7	21.7
15	53.8	53.8	53.8	9.9	9.9	9.9	5.44	21.7	21.7	21.7
14	52.7	52.7	52.7	9.9	9.9	9.9	5.33	21.8	21.8	21.8
13	51.6	51.6	51.6	9.9	9.9	9.9	5.22	21.8	21.8	21.8
12	50.5	50.5	50.5	9.9	9.9	9.9	5.11	21.8	21.8	21.8
11	49.4	49.4	49.4	9.9	9.9	9.9	5.01	21.8	21.8	21.8
10	48.3	48.3	48.3	9.9	9.9	9.9	4.90	21.8	21.8	21.8
9	46.3	46.3	46.3	9.8	9.8	9.8	4.71	21.8	21.8	21.8
8	44.5	44.5	44.5	9.8	9.8	9.8	4.53	21.8	21.8	21.8
7	42.8	42.8	42.8	9.8	9.8	9.8	4.37	21.8	21.8	21.8
6	41.2	41.2	41.2	9.8	9.8	9.8	4.21	21.8	21.8	21.8
5	39.8	39.8	39.8	9.8	9.8	9.8	4.07	21.8	21.8	21.8
4	38.5	38.5	38.5	9.8	9.8	9.8	3.94	21.8	21.8	21.8
3	37.3	37.3	37.3	9.8	9.8	9.8	3.82	21.8	21.8	21.8
2	36.2	36.2	36.2	9.8	9.8	9.8	3.71	21.8	21.8	21.8
1	35.2	35.2	35.2	9.7	9.7	9.7	3.61	21.8	21.8	21.8
0	34.3	34.3	34.3	9.7	9.7	9.7	3.52	21.8	21.8	21.8
-1	33.4	33.4	33.4	9.7	9.7	9.7	3.44	21.8	21.8	21.8
-2	32.7	32.7	32.7	9.7	9.7	9.7	3.36	21.8	21.8	21.8
-3	32.1	32.1	32.1	9.7	9.7	9.7	3.30	21.8	21.8	21.8
-4	31.5	31.5	31.5	9.7	9.7	9.7	3.24	21.8	21.8	21.8
-5	31.0	31.0	31.0	9.7	9.7	9.7	3.19	21.7	21.7	21.7
-6	30.6	30.6	30.6	9.7	9.7	9.7	3.15	21.7	21.7	21.7
-7	30.3	30.3	30.3	9.7	9.7	9.7	3.12	21.7	21.7	21.7
-8	30.0	30.0	30.0	9.7	9.7	9.7	3.09	21.7	21.7	21.7
-9	29.8	29.8	29.8	9.7	9.7	9.7	3.07	21.7	21.7	21.7
-10	29.7	29.7	29.7	9.7	9.7	9.7	3.05	21.7	21.7	21.7
-11	28.9	28.9	28.9	9.7	9.7	9.7	2.98	21.7	21.7	21.7
-12	28.2	28.2	28.2	9.7	9.7	9.7	2.90	21.7	21.7	21.7
-13	27.4	27.4	27.4	9.7	9.7	9.7	2.83	21.7	21.7	21.7
-14	26.7	26.7	26.7	9.7	9.7	9.7	2.75	21.7	21.7	21.7
-15	26.0	26.0	26.0	9.7	9.7	9.7	2.68	21.6	21.6	21.6
-16	25.3	25.3	25.3	9.7	9.7	9.7	2.61	21.6	21.6	21.6
-17	24.7	24.7	24.7	9.7	9.7	9.7	2.54	21.6	21.6	21.6
-18	24.0	24.0	24.0	9.7	9.7	9.7	2.48	21.6	21.6	21.6
-19	23.4	23.4	23.4	9.7	9.7	9.7	2.41	21.6	21.6	21.6
-20	22.7	22.7	22.7	9.7	9.7	9.7	2.35	21.5	21.5	21.5
-21	22.1	22.1	22.1	9.7	9.7	9.7	2.28	21.5	21.5	21.5
-22	21.5	21.5	21.5	9.7	9.7	9.7	2.22	21.5	21.5	21.5
-23	21.0	21.0	21.0	9.7	9.7	9.7	2.16	21.4	21.4	21.4
-24	20.4	20.4	20.4	9.7	9.7	9.7	2.10	21.4	21.4	21.4
-25	19.8	19.8	19.8	9.7	9.7	9.7	2.05	21.4	21.4	21.4

* attention: operating limits not reflected in performance table

Th [°C]		45 °C								
Ta [°C]	Qh nom [kW]	Qh min [kW]	Qh max [kW]	Pin nom [kW]	Pin-min [kW]	Pin-max [kW]	COP kW / kW	I nom [A]	I min [A]	I max [A]
25	65.7	65.7	65.7	12.4	12.4	12.4	5.28	24.0	24.0	24.0
24	64.4	64.4	64.4	12.4	12.4	12.4	5.18	24.0	24.0	24.0
23	63.1	63.1	63.1	12.4	12.4	12.4	5.09	24.0	24.0	24.0
22	61.9	61.9	61.9	12.4	12.4	12.4	4.99	24.0	24.0	24.0
21	60.7	60.7	60.7	12.4	12.4	12.4	4.90	24.0	24.0	24.0
20	59.5	59.5	59.5	12.4	12.4	12.4	4.80	24.0	24.0	24.0
19	58.3	58.3	58.3	12.4	12.4	12.4	4.71	24.0	24.0	24.0
18	57.1	57.1	57.1	12.3	12.3	12.3	4.62	24.0	24.0	24.0
17	55.9	55.9	55.9	12.3	12.3	12.3	4.53	23.9	23.9	23.9
16	54.8	54.8	54.8	12.3	12.3	12.3	4.45	23.9	23.9	23.9
15	53.7	53.7	53.7	12.3	12.3	12.3	4.36	23.9	23.9	23.9
14	52.6	52.6	52.6	12.3	12.3	12.3	4.27	23.9	23.9	23.9
13	51.5	51.5	51.5	12.3	12.3	12.3	4.19	23.9	23.9	23.9
12	50.4	50.4	50.4	12.3	12.3	12.3	4.10	23.9	23.9	23.9
11	49.3	49.3	49.3	12.3	12.3	12.3	4.02	23.9	23.9	23.9
10	48.3	48.3	48.3	12.3	12.3	12.3	3.94	23.9	23.9	23.9
9	46.4	46.4	46.4	12.2	12.2	12.2	3.79	23.8	23.8	23.8
8	44.6	44.6	44.6	12.2	12.2	12.2	3.65	23.8	23.8	23.8
7	43.0	43.0	43.0	12.2	12.2	12.2	3.52	23.8	23.8	23.8
6	41.4	41.4	41.4	12.2	12.2	12.2	3.40	23.8	23.8	23.8
5	40.0	40.0	40.0	12.2	12.2	12.2	3.29	23.7	23.7	23.7
4	38.8	38.8	38.8	12.2	12.2	12.2	3.19	23.7	23.7	23.7
3	37.6	37.6	37.6	12.2	12.2	12.2	3.09	23.7	23.7	23.7
2	36.5	36.5	36.5	12.1	12.1	12.1	3.00	23.7	23.7	23.7
1	35.5	35.5	35.5	12.1	12.1	12.1	2.93	23.7	23.7	23.7
0	34.6	34.6	34.6	12.1	12.1	12.1	2.85	23.6	23.6	23.6
-1	33.8	33.8	33.8	12.1	12.1	12.1	2.79	23.6	23.6	23.6
-2	33.1	33.1	33.1	12.1	12.1	12.1	2.73	23.6	23.6	23.6
-3	32.5	32.5	32.5	12.1	12.1	12.1	2.68	23.6	23.6	23.6
-4	32.0	32.0	32.0	12.1	12.1	12.1	2.64	23.6	23.6	23.6
-5	31.5	31.5	31.5	12.1	12.1	12.1	2.60	23.6	23.6	23.6
-6	31.1	31.1	31.1	12.1	12.1	12.1	2.57	23.5	23.5	23.5
-7	30.7	30.7	30.7	12.1	12.1	12.1	2.54	23.5	23.5	23.5
-8	30.5	30.5	30.5	12.1	12.1	12.1	2.52	23.5	23.5	23.5
-9	30.3	30.3	30.3	12.1	12.1	12.1	2.50	23.5	23.5	23.5
-10	30.2	30.2	30.2	12.1	12.1	12.1	2.49	23.5	23.5	23.5
-11	29.4	29.4	29.4	12.1	12.1	12.1	2.43	23.5	23.5	23.5
-12	28.7	28.7	28.7	12.1	12.1	12.1	2.37	23.5	23.5	23.5
-13	28.0	28.0	28.0	12.1	12.1	12.1	2.31	23.5	23.5	23.5
-14	27.3	27.3	27.3	12.1	12.1	12.1	2.25	23.4	23.4	23.4
-15	26.6	26.6	26.6	12.1	12.1	12.1	2.20	23.4	23.4	23.4
-16	25.9	25.9	25.9	12.1	12.1	12.1	2.14	23.4	23.4	23.4
-17	25.2	25.2	25.2	12.1	12.1	12.1	2.09	23.3	23.3	23.3
-18	24.6	24.6	24.6	12.1	12.1	12.1	2.03	23.3	23.3	23.3
-19	24.0	24.0	24.0	12.1	12.1	12.1	1.98	23.3	23.3	23.3
-20	23.3	23.3	23.3	12.1	12.1	12.1	1.93	23.3	23.3	23.3
-21	22.7	22.7	22.7	12.1	12.1	12.1	1.88	23.2	23.2	23.2
-22	22.2	22.2	22.2	12.1	12.1	12.1	1.83	23.2	23.2	23.2
-23	21.6	21.6	21.6	12.1	12.1	12.1	1.78	23.2	23.2	23.2
-24	21.0	21.0	21.0	12.1	12.1	12.1	1.73	23.1	23.1	23.1
-25	20.5	20.5	20.5	12.1	12.1	12.1	1.69	23.1	23.1	23.1

* attention: operating limits not reflected in performance table

Th [°C]		55 °C								
Ta [°C]	Qh nom [kW]	Qh min [kW]	Qh max [kW]	Pin nom [kW]	Pin-min [kW]	Pin-max [kW]	COP kW / kW	I nom [A]	I min [A]	I max [A]
25	65.3	65.3	65.3	15.8	15.8	15.8	4.14	27.3	27.3	27.3
24	64.1	64.1	64.1	15.7	15.7	15.7	4.07	27.3	27.3	27.3
23	62.9	62.9	62.9	15.7	15.7	15.7	4.00	27.2	27.2	27.2
22	61.7	61.7	61.7	15.7	15.7	15.7	3.93	27.2	27.2	27.2
21	60.5	60.5	60.5	15.7	15.7	15.7	3.86	27.2	27.2	27.2
20	59.4	59.4	59.4	15.7	15.7	15.7	3.79	27.2	27.2	27.2
19	58.2	58.2	58.2	15.7	15.7	15.7	3.72	27.2	27.2	27.2
18	57.1	57.1	57.1	15.7	15.7	15.7	3.65	27.1	27.1	27.1
17	56.0	56.0	56.0	15.6	15.6	15.6	3.58	27.1	27.1	27.1
16	54.9	54.9	54.9	15.6	15.6	15.6	3.51	27.1	27.1	27.1
15	53.8	53.8	53.8	15.6	15.6	15.6	3.45	27.1	27.1	27.1
14	52.7	52.7	52.7	15.6	15.6	15.6	3.38	27.1	27.1	27.1
13	51.7	51.7	51.7	15.6	15.6	15.6	3.32	27.1	27.1	27.1
12	50.7	50.7	50.7	15.6	15.6	15.6	3.25	27.0	27.0	27.0
11	49.6	49.6	49.6	15.6	15.6	15.6	3.19	27.0	27.0	27.0
10	48.6	48.6	48.6	15.6	15.6	15.6	3.13	27.0	27.0	27.0
9	46.8	46.8	46.8	15.5	15.5	15.5	3.01	27.0	27.0	27.0
8	45.1	45.1	45.1	15.5	15.5	15.5	2.91	26.9	26.9	26.9
7	43.5	43.5	43.5	15.5	15.5	15.5	2.81	26.9	26.9	26.9
6	42.1	42.1	42.1	15.5	15.5	15.5	2.72	26.9	26.9	26.9
5	40.7	40.7	40.7	15.5	15.5	15.5	2.63	26.9	26.9	26.9
4	39.5	39.5	39.5	15.5	15.5	15.5	2.55	26.9	26.9	26.9
3	38.3	38.3	38.3	15.4	15.4	15.4	2.48	26.8	26.8	26.8
2	37.3	37.3	37.3	15.4	15.4	15.4	2.42	26.8	26.8	26.8
1	36.3	36.3	36.3	15.4	15.4	15.4	2.36	26.8	26.8	26.8
0	35.5	35.5	35.5	15.4	15.4	15.4	2.30	26.8	26.8	26.8
-1	34.7	34.7	34.7	15.4	15.4	15.4	2.25	26.8	26.8	26.8
-2	34.0	34.0	34.0	15.4	15.4	15.4	2.21	26.8	26.8	26.8
-3	33.4	33.4	33.4	15.4	15.4	15.4	2.17	26.7	26.7	26.7
-4	32.9	32.9	32.9	15.4	15.4	15.4	2.13	26.7	26.7	26.7
-5	32.4	32.4	32.4	15.4	15.4	15.4	2.11	26.7	26.7	26.7
-6	32.0	32.0	32.0	15.4	15.4	15.4	2.08	26.7	26.7	26.7
-7	31.7	31.7	31.7	15.4	15.4	15.4	2.06	26.7	26.7	26.7
-8	31.5	31.5	31.5	15.4	15.4	15.4	2.04	26.7	26.7	26.7
-9	31.3	31.3	31.3	15.4	15.4	15.4	2.03	26.7	26.7	26.7
-10	31.1	31.1	31.1	15.4	15.4	15.4	2.02	26.7	26.7	26.7
-11	30.4	30.4	30.4	15.4	15.4	15.4	1.98	26.7	26.7	26.7
-12	29.7	29.7	29.7	15.4	15.4	15.4	1.93	26.7	26.7	26.7
-13	29.0	29.0	29.0	15.4	15.4	15.4	1.88	26.6	26.6	26.6
-14	28.3	28.3	28.3	15.4	15.4	15.4	1.84	26.6	26.6	26.6
-15	27.7	27.7	27.7	15.4	15.4	15.4	1.80	26.6	26.6	26.6
-16	27.0	27.0	27.0	15.4	15.4	15.4	1.75	26.6	26.6	26.6
-17	26.4	26.4	26.4	15.4	15.4	15.4	1.71	26.6	26.6	26.6
-18	25.7	25.7	25.7	15.4	15.4	15.4	1.67	26.6	26.6	26.6
-19	25.1	25.1	25.1	15.4	15.4	15.4	1.63	26.5	26.5	26.5
-20	24.5	24.5	24.5	15.4	15.4	15.4	1.59	26.5	26.5	26.5
-21	23.9	23.9	23.9	15.4	15.4	15.4	1.55	26.5	26.5	26.5
-22	23.3	23.3	23.3	15.4	15.4	15.4	1.51	26.5	26.5	26.5
-23	22.8	22.8	22.8	15.4	15.4	15.4	1.48	26.5	26.5	26.5
-24	22.2	22.2	22.2	15.4	15.4	15.4	1.44	26.4	26.4	26.4
-25	21.7	21.7	21.7	15.4	15.4	15.4	1.40	26.4	26.4	26.4

* attention: operating limits not reflected in performance table

Th [°C]		T-Max @ 65 °C								
Ta [°C]	Qh nom [kW]	Qh min [kW]	Qh max [kW]	Pin nom [kW]	Pin-min [kW]	Pin-max [kW]	COP kW / kW	I nom [A]	I min [A]	I max [A]
25	65.5	65.5	65.5	20.2	20.2	20.2	3.24	32.7	32.7	32.7
24	64.4	64.4	64.4	20.2	20.2	20.2	3.18	32.7	32.7	32.7
23	63.2	63.2	63.2	20.2	20.2	20.2	3.13	32.7	32.7	32.7
22	62.1	62.1	62.1	20.2	20.2	20.2	3.08	32.7	32.7	32.7
21	61.0	61.0	61.0	20.2	20.2	20.2	3.02	32.7	32.7	32.7
20	59.9	59.9	59.9	20.2	20.2	20.2	2.97	32.6	32.6	32.6
19	58.8	58.8	58.8	20.1	20.1	20.1	2.92	32.6	32.6	32.6
18	57.7	57.7	57.7	20.1	20.1	20.1	2.87	32.6	32.6	32.6
17	56.7	56.7	56.7	20.1	20.1	20.1	2.82	32.6	32.6	32.6
16	55.6	55.6	55.6	20.1	20.1	20.1	2.77	32.6	32.6	32.6
15	54.6	54.6	54.6	20.1	20.1	20.1	2.72	32.6	32.6	32.6
14	53.6	53.6	53.6	20.1	20.1	20.1	2.67	32.6	32.6	32.6
13	52.6	52.6	52.6	20.0	20.0	20.0	2.62	32.6	32.6	32.6
12	51.6	51.6	51.6	20.0	20.0	20.0	2.57	32.6	32.6	32.6
11	50.6	50.6	50.6	20.0	20.0	20.0	2.53	32.6	32.6	32.6
10	49.6	49.6	49.6	20.0	20.0	20.0	2.48	32.6	32.6	32.6
9	47.9	47.9	47.9	20.0	20.0	20.0	2.40	32.5	32.5	32.5
8	46.3	46.3	46.3	20.0	20.0	20.0	2.32	32.5	32.5	32.5
7	44.8	44.8	44.8	19.9	19.9	19.9	2.24	32.5	32.5	32.5
6	43.4	43.4	43.4	19.9	19.9	19.9	2.18	32.5	32.5	32.5
5	42.1	42.1	42.1	19.9	19.9	19.9	2.11	32.5	32.5	32.5
4	40.9	40.9	40.9	19.9	19.9	19.9	2.05	32.5	32.5	32.5
3	39.8	39.8	39.8	19.9	19.9	19.9	2.00	32.5	32.5	32.5
2	38.8	38.8	38.8	19.9	19.9	19.9	1.95	32.5	32.5	32.5
1	37.9	37.9	37.9	19.9	19.9	19.9	1.91	32.5	32.5	32.5
0	37.1	37.1	37.1	19.9	19.9	19.9	1.87	32.5	32.5	32.5
-1	36.4	36.4	36.4	19.9	19.9	19.9	1.83	32.5	32.5	32.5
-2	35.7	35.7	35.7	19.9	19.9	19.9	1.80	32.6	32.6	32.6
-3	35.1	35.1	35.1	19.9	19.9	19.9	1.77	32.6	32.6	32.6
-4	34.6	34.6	34.6	19.9	19.9	19.9	1.74	32.6	32.6	32.6
-5	34.2	34.2	34.2	19.9	19.9	19.9	1.72	32.6	32.6	32.6
-6	33.8	33.8	33.8	19.9	19.9	19.9	1.70	32.6	32.6	32.6
-7	33.5	33.5	33.5	19.9	19.9	19.9	1.68	32.6	32.6	32.6
-8	33.2	33.2	33.2	19.9	19.9	19.9	1.67	32.6	32.6	32.6
-9	33.0	33.0	33.0	19.9	19.9	19.9	1.66	32.6	32.6	32.6
-10	32.9	32.9	32.9	19.9	19.9	19.9	1.66	32.6	32.6	32.6
-11	32.2	32.2	32.2	19.9	19.9	19.9	1.62	32.6	32.6	32.6
-12	31.5	31.5	31.5	19.9	19.9	19.9	1.59	32.6	32.6	32.6
-13	30.9	30.9	30.9	19.9	19.9	19.9	1.55	32.6	32.6	32.6
-14	30.2	30.2	30.2	19.9	19.9	19.9	1.52	32.6	32.6	32.6
-15	29.6	29.6	29.6	19.9	19.9	19.9	1.49	32.6	32.6	32.6
-16										
-17										
-18										
-19										
-20										
-21										
-22										
-23										
-24										
-25										

* attention: operating limits not reflected in performance table

Tc [°C]		W 12 / 7 °C								
Ta [°C]	Qc nom [kW]	Qc min [kW]	Qc max [kW]	Pin [kW]	Pin min [kW]	Pin max [kW]	EER kW / kW	I nom [A]	I min [A]	I max [A]
40	30.4	30.4	30.4	13.1	13.1	13.1	2.32	24.5	24.5	24.5
39	30.6	30.6	30.6	12.8	12.8	12.8	2.40	24.3	24.3	24.3
38	30.8	30.8	30.8	12.5	12.5	12.5	2.47	24.0	24.0	24.0
37	31.0	31.0	31.0	12.2	12.2	12.2	2.54	23.8	23.8	23.8
36	31.2	31.2	31.2	11.9	11.9	11.9	2.62	23.5	23.5	23.5
35	31.4	31.4	31.4	11.7	11.7	11.7	2.70	23.3	23.3	23.3
34	31.7	31.7	31.7	11.4	11.4	11.4	2.78	23.1	23.1	23.1
33	31.9	31.9	31.9	11.1	11.1	11.1	2.86	22.9	22.9	22.9
32	32.0	32.0	32.0	10.9	10.9	10.9	2.94	22.7	22.7	22.7
31	32.2	32.2	32.2	10.7	10.7	10.7	3.02	22.5	22.5	22.5
30	32.4	32.4	32.4	10.4	10.4	10.4	3.11	22.3	22.3	22.3
29	32.6	32.6	32.6	10.2	10.2	10.2	3.19	22.2	22.2	22.2
28	32.8	32.8	32.8	10.0	10.0	10.0	3.28	22.0	22.0	22.0
27	33.0	33.0	33.0	9.8	9.8	9.8	3.37	21.8	21.8	21.8
26	33.1	33.1	33.1	9.6	9.6	9.6	3.45	21.6	21.6	21.6
25	33.3	33.3	33.3	9.4	9.4	9.4	3.54	21.4	21.4	21.4
24	33.5	33.5	33.5	9.2	9.2	9.2	3.64	21.2	21.2	21.2
23	33.6	33.6	33.6	9.0	9.0	9.0	3.73	21.0	21.0	21.0
22	33.8	33.8	33.8	8.8	8.8	8.8	3.82	20.8	20.8	20.8
21	33.9	33.9	33.9	8.7	8.7	8.7	3.92	20.6	20.6	20.6
20	34.1	34.1	34.1	8.5	8.5	8.5	4.01	20.4	20.4	20.4
19	34.2	34.2	34.2	8.3	8.3	8.3	4.11	20.2	20.2	20.2
18	34.4	34.4	34.4	8.2	8.2	8.2	4.21	19.9	19.9	19.9
17	34.5	34.5	34.5	8.0	8.0	8.0	4.31	19.7	19.7	19.7

Tc [°C]		W 23 / 18 °C								
Ta [°C]	Qc [kW]	Qh-min [kW]	Qh-max [kW]	Pin [kW]	Pin-min [kW]	Pin-max [kW]	EER kW / kW	I [A]	I-min [A]	I-max [A]
40	41.4	41.4	41.4	13.1	13.1	13.1	3.16	24.7	24.7	24.7
39	41.6	41.6	41.6	12.8	12.8	12.8	3.26	24.4	24.4	24.4
38	41.9	41.9	41.9	12.5	12.5	12.5	3.36	24.2	24.2	24.2
37	42.2	42.2	42.2	12.2	12.2	12.2	3.46	23.9	23.9	23.9
36	42.4	42.4	42.4	11.9	11.9	11.9	3.56	23.7	23.7	23.7
35	42.7	42.7	42.7	11.7	11.7	11.7	3.66	23.4	23.4	23.4
34	42.9	42.9	42.9	11.4	11.4	11.4	3.76	23.2	23.2	23.2
33	43.1	43.1	43.1	11.1	11.1	11.1	3.87	23.0	23.0	23.0
32	43.4	43.4	43.4	10.9	10.9	10.9	3.98	22.8	22.8	22.8
31	43.6	43.6	43.6	10.7	10.7	10.7	4.09	22.6	22.6	22.6
30	43.8	43.8	43.8	10.4	10.4	10.4	4.20	22.4	22.4	22.4
29	44.0	44.0	44.0	10.2	10.2	10.2	4.31	22.2	22.2	22.2
28	44.3	44.3	44.3	10.0	10.0	10.0	4.42	22.0	22.0	22.0
27	44.5	44.5	44.5	9.8	9.8	9.8	4.54	21.8	21.8	21.8
26	44.7	44.7	44.7	9.6	9.6	9.6	4.66	21.5	21.5	21.5
25	44.9	44.9	44.9	9.4	9.4	9.4	4.77	21.3	21.3	21.3
24	45.1	45.1	45.1	9.2	9.2	9.2	4.89	21.1	21.1	21.1
23	45.3	45.3	45.3	9.0	9.0	9.0	5.02	20.9	20.9	20.9
22	45.4	45.4	45.4	8.8	8.8	8.8	5.14	20.6	20.6	20.6
21	45.6	45.6	45.6	8.7	8.7	8.7	5.26	20.4	20.4	20.4
20	45.8	45.8	45.8	8.5	8.5	8.5	5.39	20.1	20.1	20.1
19	46.0	46.0	46.0	8.3	8.3	8.3	5.52	19.9	19.9	19.9
18	46.1	46.1	46.1	8.2	8.2	8.2	5.65	19.6	19.6	19.6
17	46.3	46.3	46.3	8.0	8.0	8.0	5.78	19.3	19.3	19.3

* attention: operating limits not reflected in performance table

LEGENDE:

Ts-IN: Temperature renewable source - inlet [°C]
Th-OU: Temperature heating - outlet (flow) [°C]
Tc-OU: Temperature cooling - outlet (flow) [°C]
Qh nom: Heating capacity nominal
Qh min: Heating capacity minimal
Qh max: Heating capacity maximal
Pin nom: Power input at nominal heating capacity
Pin min: Power input at minimal heating capacity
Pin max: Power input at maximal heating capacity
COP nom: coefficient of performance at nominal heating capacity
Qc nom: cooling / heat extraction capacity at nominal heating capacity
Qc min: cooling / heat extraction at minimal heating capacity
Qc max: cooling / heat extraction at maximal heating capacity
I nom: Current at nominal heating capacity
EER: energy efficiency ratio at nominal cooling capacity

Operating limits

°C

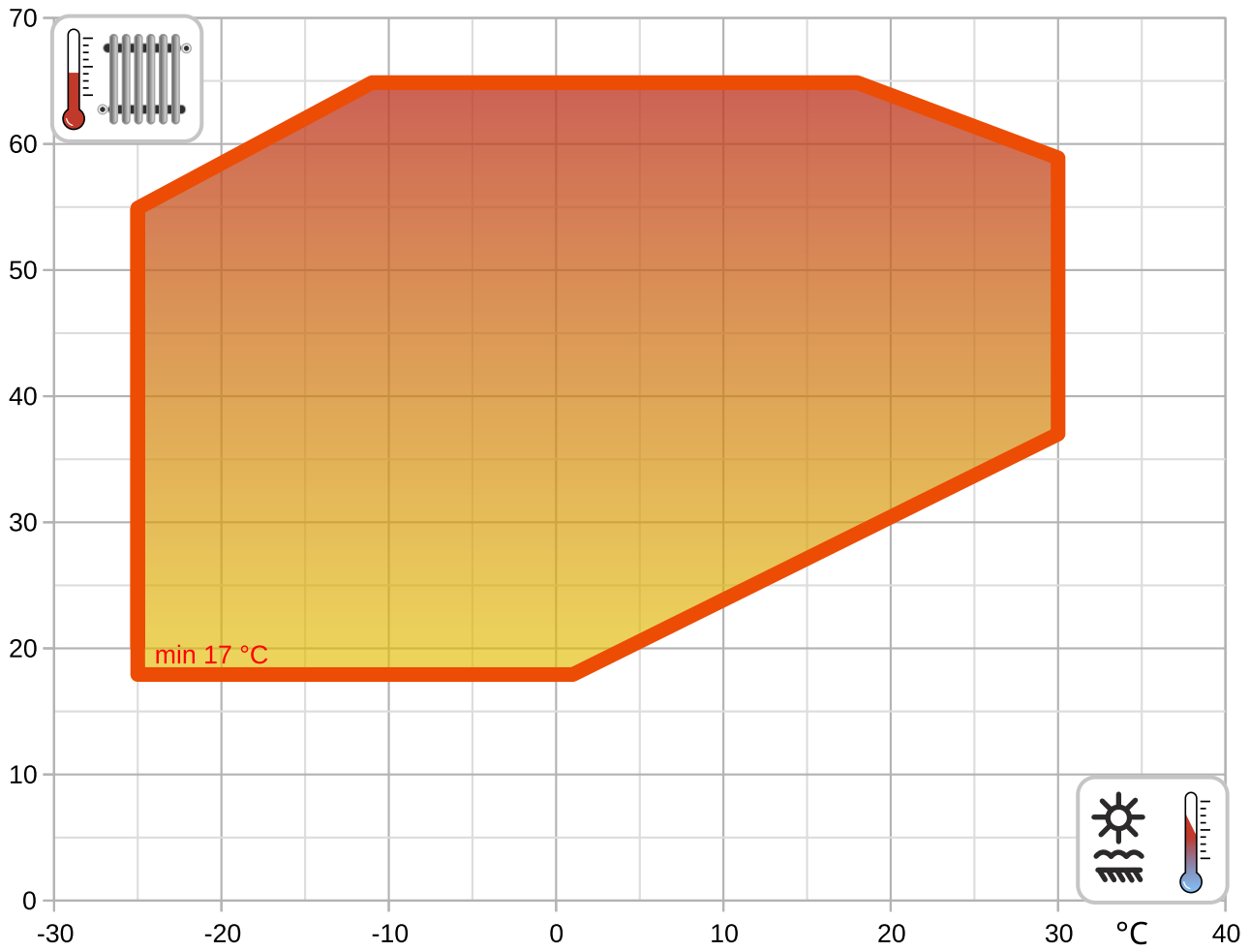

°C

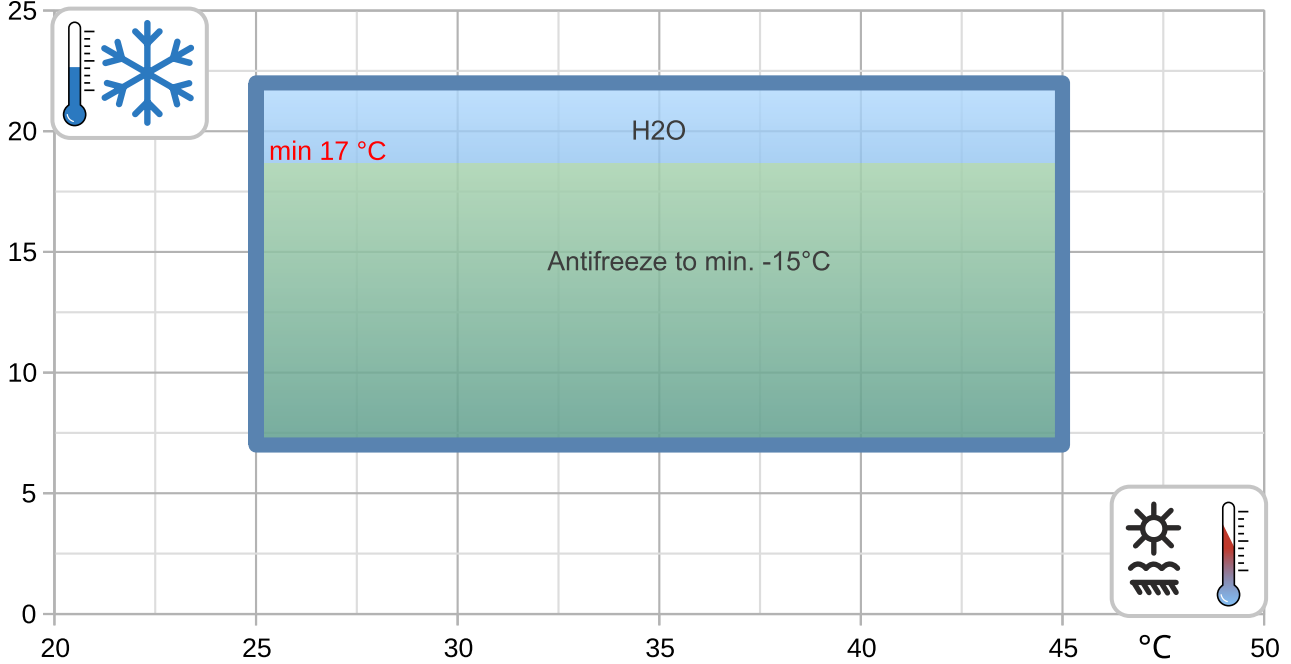

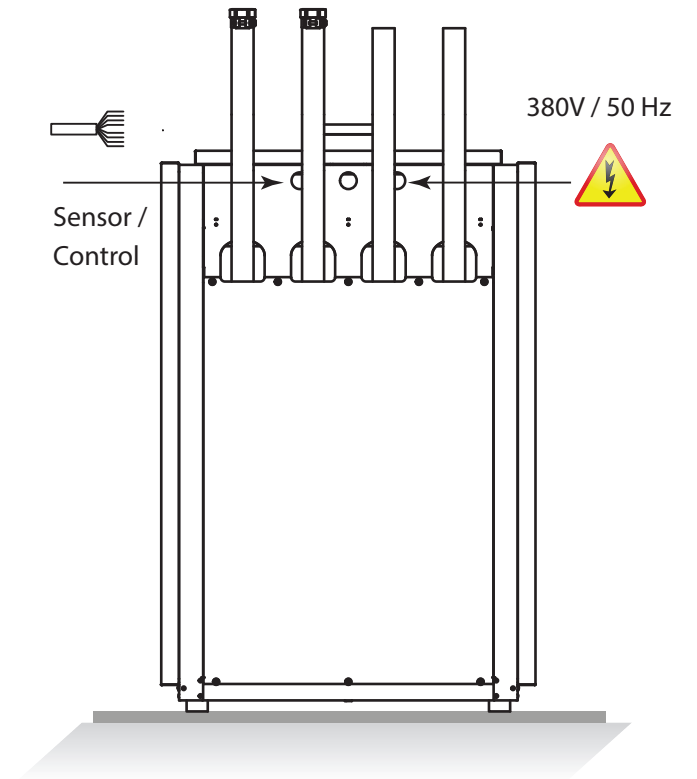
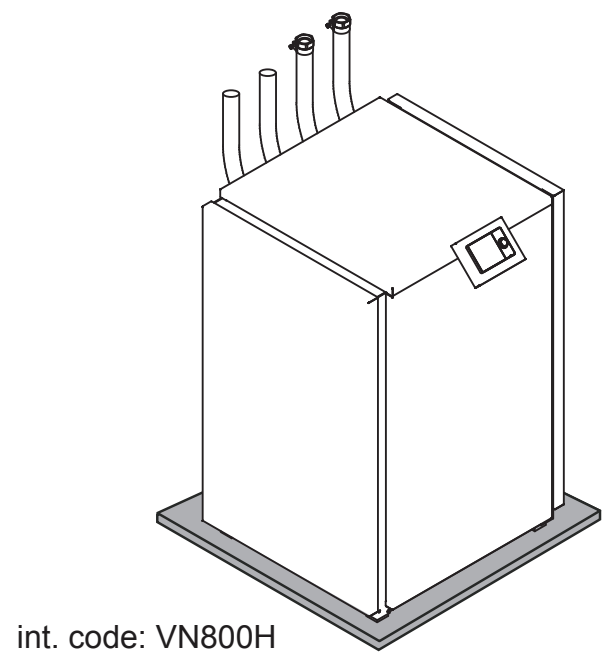
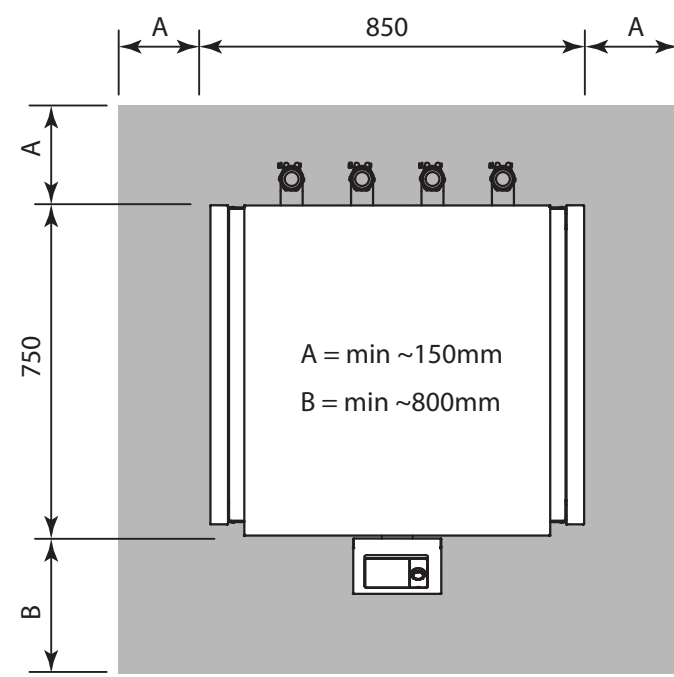
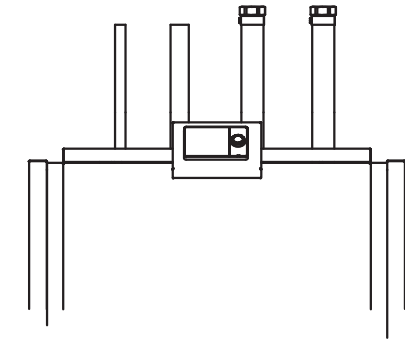
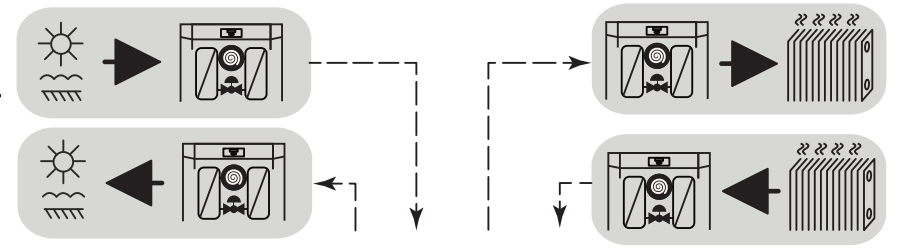
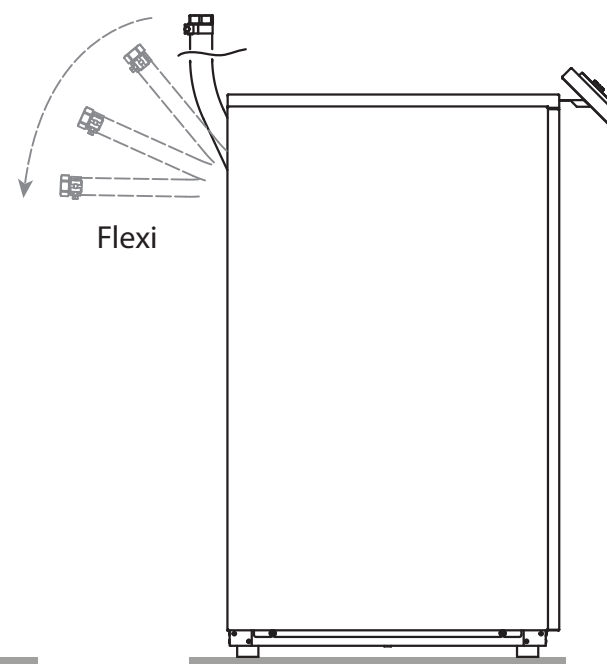
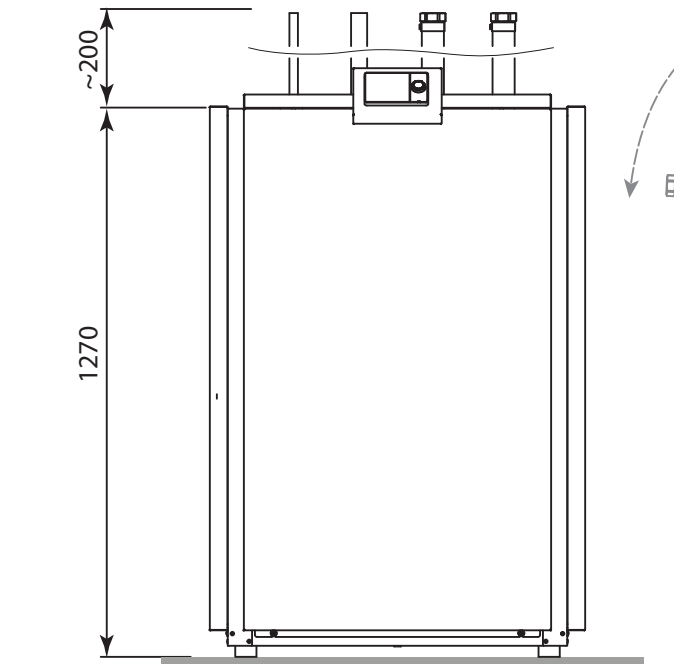

WAMAK AW 40 EVI - Split unit variant: VOV-900



Enclosure type: VOV-900			Evaporator	
Article	WAVV0900		Type	Cu-coil /Al-fin "
Basic dimensions	Height [mm]	1320	Port size	5/8" - 1.1/8" "
	Width [mm]	1390	Heat transfer medium	Air
	Length [mm]	1150	Volume flow - Air [m3/h]	13200
Weight [kg]	210		Internal pressure drop - Air [kPa]	0.024
Colour	Inox		Temperature difference - Air	7 K
Enclosure IP Class	IP44		Expansion valve	EEV
Fan	800 mm			
Number of fans	1		Fan mounting position	Vertical axis
Fan motor type	EC		Fan type	Axial
Fan nominal current [A]	1.35		Fan power supply [V/Hz]	3~ 400/50
Minimal fan power input [Watt]	81		Maximal fan power input [Watt]	802

Acoustic power Lw

66.8 dB(A)

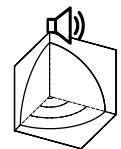
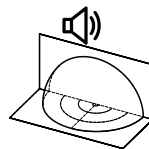
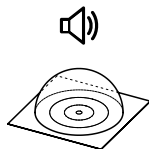

Distance [m]	1				5				10				15			
	1	5	10	15	1	5	10	15	1	5	10	15	1	5	10	15
Acoustic pressure Lp [dB(A)]	61.8	47.8	41.8	38.3	64.8	50.8	44.8	41.3	58.8	44.8	38.8	35.3				

EC Fan 800mm

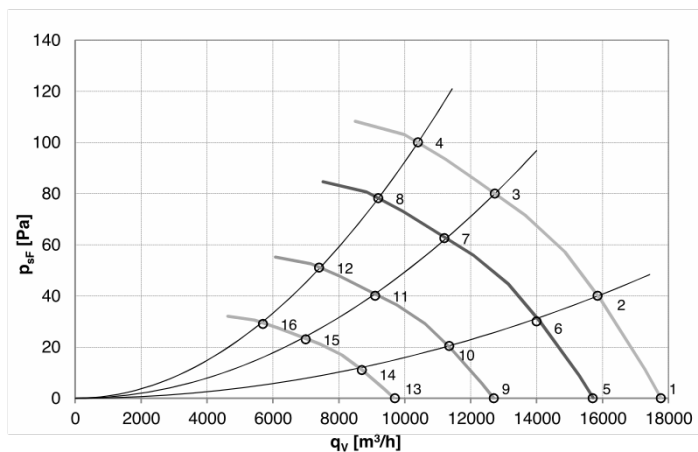

	U	f	n	qv	P _{sF}	P _e	I	L _{wA out}	T _{a max}
	[V]	[Hz]	[RPM]	[m³/h]	[Pa]	[W]	[A]	[dB (A)]	[°C]
1	400	50	735	17770	0	503	0,85	70	60
2	400	50	735	15850	40	612	1,02	66	60
3	400	50	735	12730	80	735	1,18	65	60
4	400	50	735	10400	100	802	1,36	68	60
5	400	50	650	15700	0	348	0,68	67	60
6	400	50	650	14000	30	421	0,80	63	60
7	400	50	650	11200	63	510	0,92	62	60
8	400	50	650	9200	78	554	0,93	65	60
9	400	50	525	12700	0	183	0,38	63	60
10	400	50	525	11350	20	225	0,35	59	60
11	400	50	525	9100	40	265	0,53	58	60
12	400	50	525	7400	51	292	0,57	61	60
13	400	50	400	9700	0	81	0,21	57	60
14	400	50	400	8700	11	97	0,24	53	60
15	400	50	400	7000	23	117	0,27	52	60
16	400	50	400	5700	29	128	0,28	55	60

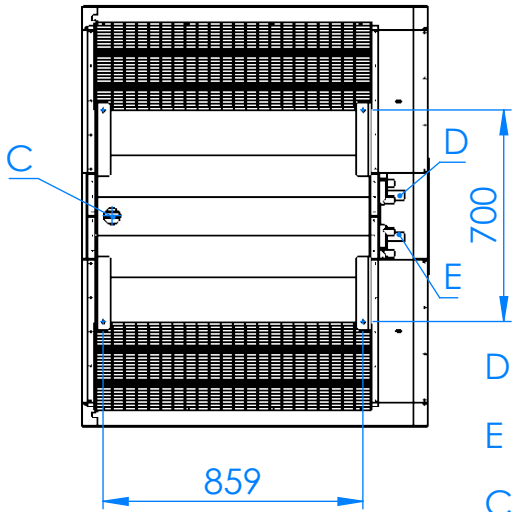
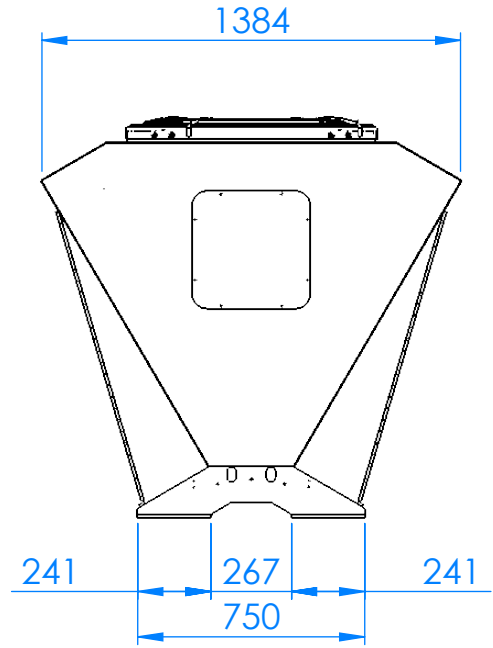
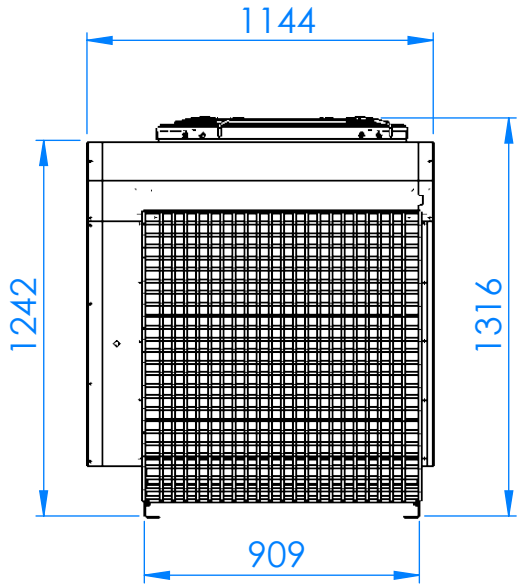

D - FRIGO GAS
E - FRIGO LIQUID
C - CONDENS

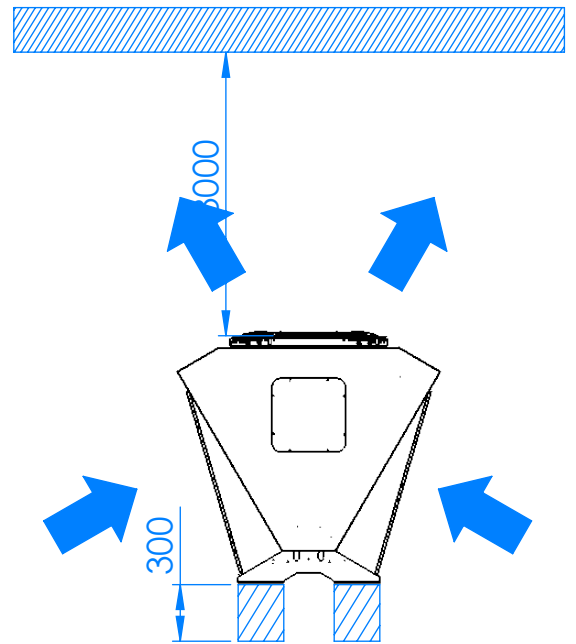
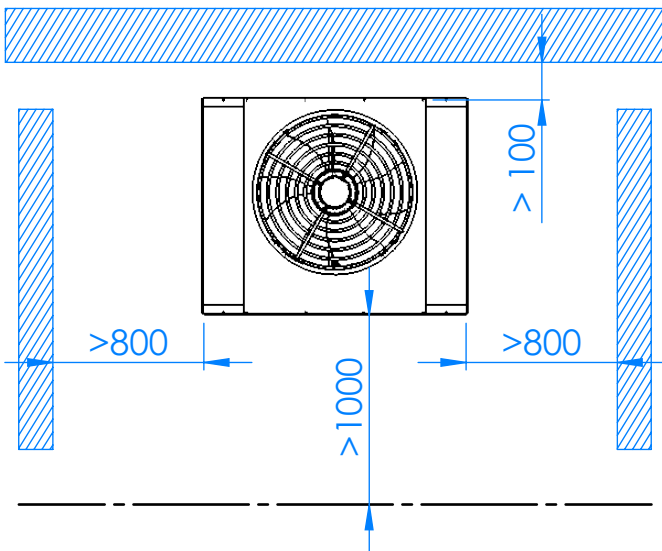
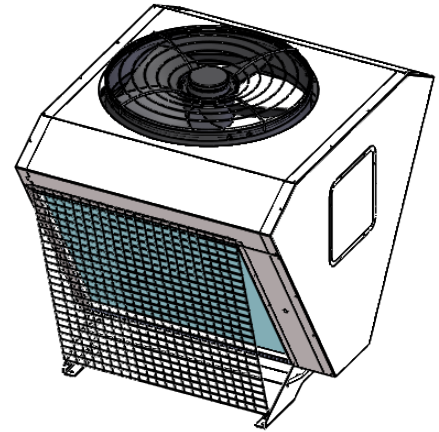

WAMAK AW 40 EVI - Split unit variant: VOII-1200-2LOW

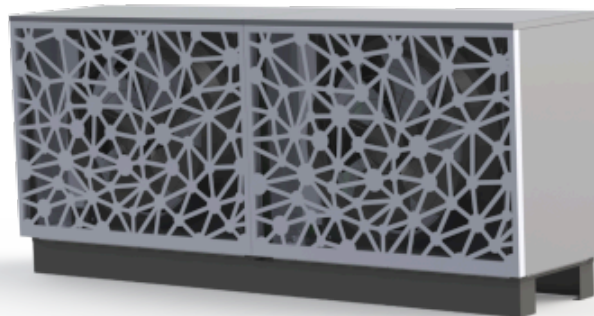

Enclosure type: VOII-1200-2LOW			Evaporator	
Article	WAVII12L		Type	Cu-coil /Al-fin "
Basic dimensions	Height [mm]	1240	Port size	5/8" - 1.1/8" "
	Width [mm]	2850	Heat transfer medium	Air
	Length [mm]	710	Volume flow - Air [m3/h]	13200
Weight [kg]	300		Internal pressure drop - Air [kPa]	0.024
Colour	Gray		Temperature difference - Air	7 K
Enclosure IP Class	IP44		Expansion valve	EEV
Fan	800 mm			
Number of fans	2		Fan mounting position	Horizontal axis
Fan motor type	EC		Fan type	Axial
Fan nominal current [A]	1.35		Fan power supply [V/Hz]	3~ 400/50
Minimal fan power input [Watt]	81		Maximal fan power input [Watt]	802

Acoustic power Lw

62.5 dB(A)

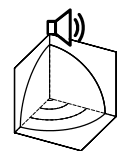
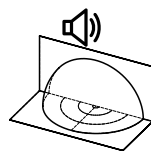
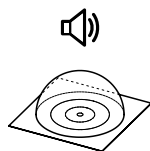

Distance [m]	1				5				10				15			
	1	5	10	15	1	5	10	15	1	5	10	15	1	5	10	15
Acoustic pressure Lp [dB(A)]	57.5	43.5	37.5	34	60.5	46.5	40.5	37	54.5	40.5	34.5	31				

EC Fan 800mm

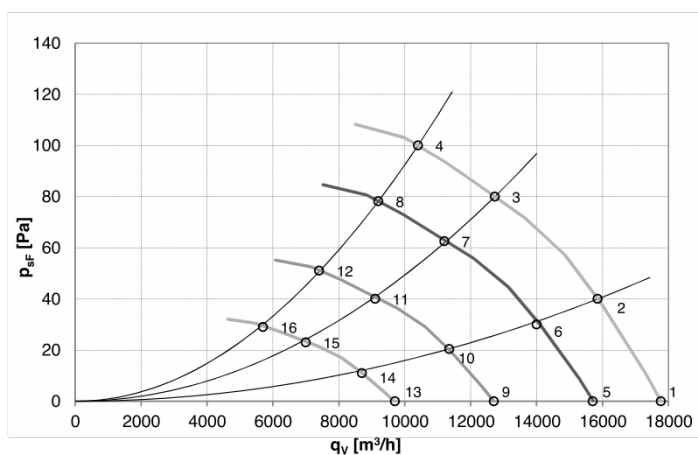

	U	f	n	qv	P _{sF}	P _e	I	L _{WA out}	T _{a max}
	[V]	[Hz]	[RPM]	[m³/h]	[Pa]	[W]	[A]	[dB (A)]	[°C]
1	400	50	735	17770	0	503	0,85	70	60
2	400	50	735	15850	40	612	1,02	66	60
3	400	50	735	12730	80	735	1,18	65	60
4	400	50	735	10400	100	802	1,36	68	60
5	400	50	650	15700	0	348	0,68	67	60
6	400	50	650	14000	30	421	0,80	63	60
7	400	50	650	11200	63	510	0,92	62	60
8	400	50	650	9200	78	554	0,93	65	60
9	400	50	525	12700	0	183	0,38	63	60
10	400	50	525	11350	20	225	0,35	59	60
11	400	50	525	9100	40	265	0,53	58	60
12	400	50	525	7400	51	292	0,57	61	60
13	400	50	400	9700	0	81	0,21	57	60
14	400	50	400	8700	11	97	0,24	53	60
15	400	50	400	7000	23	117	0,27	52	60
16	400	50	400	5700	29	128	0,28	55	60

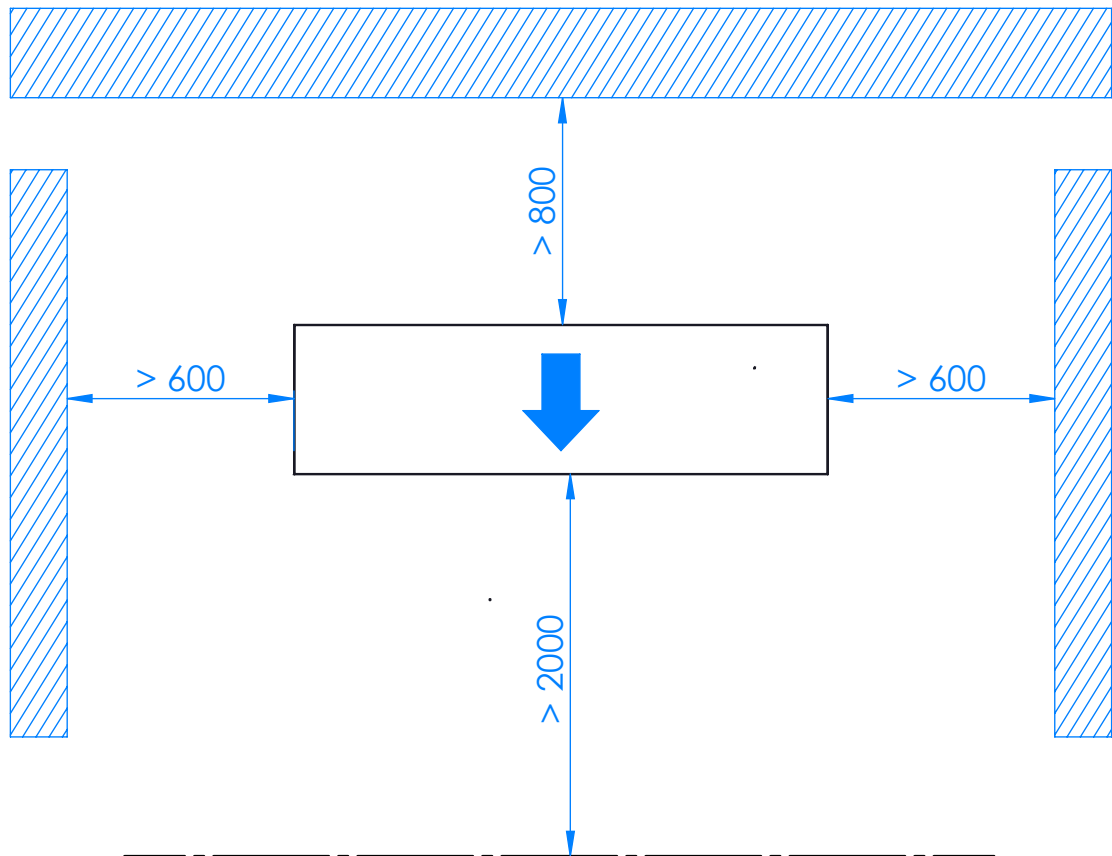
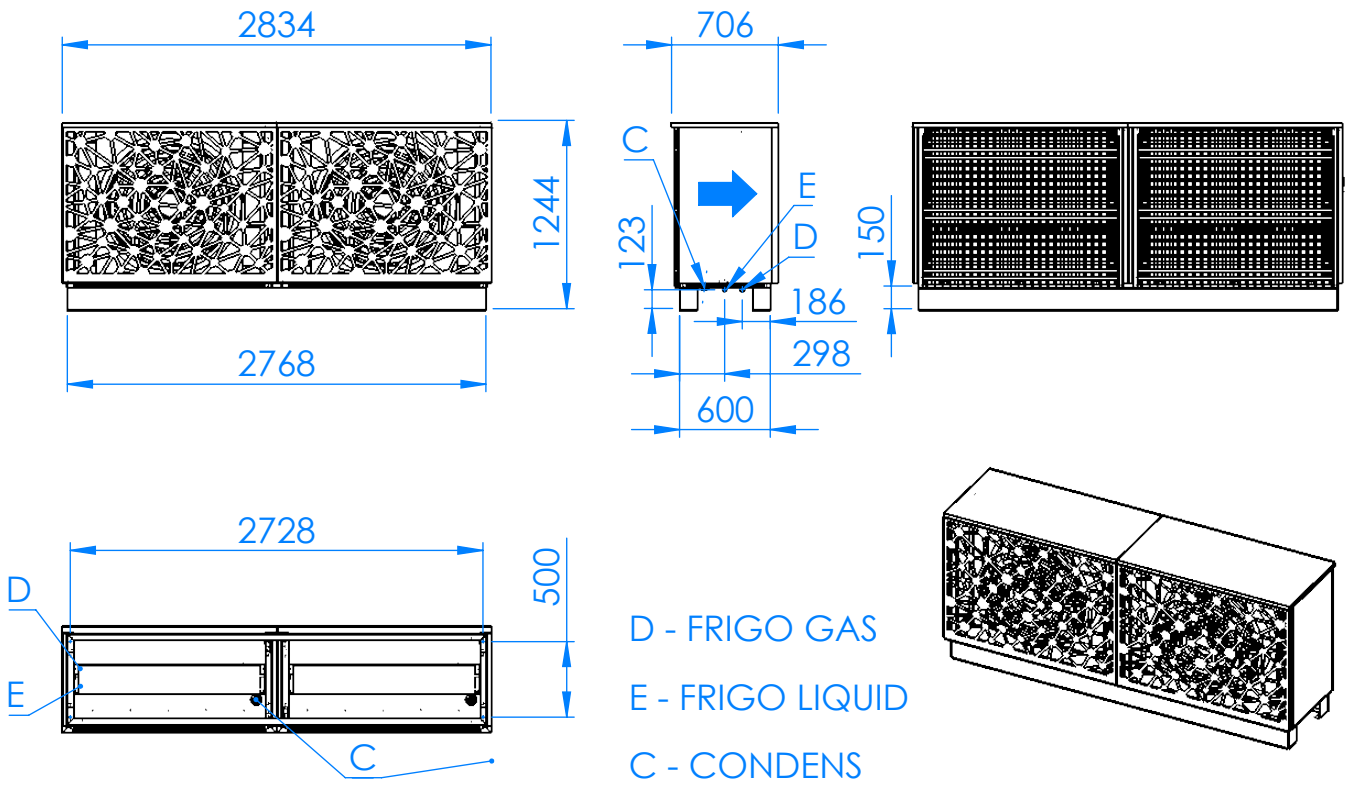

WAMAK AW 40 EVI - Split unit variant: VOII-1200-2HIGH

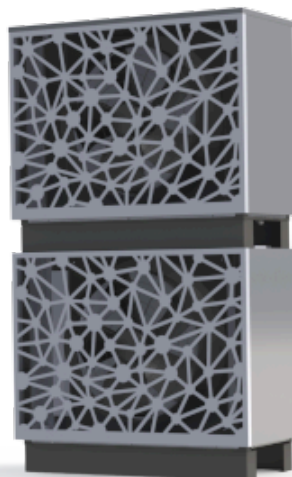

Enclosure type: VOII-1200-2HIGH			Evaporator	
Article	WAVII12H		Type	Cu-coil /Al-fin "
Basic dimensions	Height [mm]	2450	Port size	5/8" - 1.1/8" "
	Width [mm]	1420	Heat transfer medium	Air
	Length [mm]	710	Volume flow - Air [m3/h]	13200
Weight [kg]	300		Internal pressure drop - Air [kPa]	0.024
Colour	Gray		Temperature difference - Air	7 K
Enclosure IP Class	IP44		Expansion valve	EEV
Fan	800 mm			
Number of fans	2		Fan mounting position	Horizontal axis
Fan motor type	EC		Fan type	Axial
Fan nominal current [A]	1.35		Fan power supply [V/Hz]	3~ 400/50
Minimal fan power input [Watt]	81		Maximal fan power input [Watt]	802

Acoustic power L_w

62.5 dB(A)

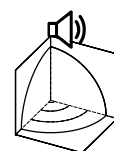
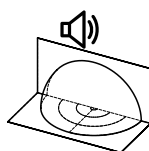
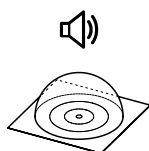

Distance [m]	1				5				10				15			
	1	5	10	15	1	5	10	15	1	5	10	15	1	5	10	15
Acoustic pressure L _p [dB(A)]	57.5	43.5	37.5	34	60.5	46.5	40.5	37	54.5	40.5	34.5	31				

EC Fan 800mm

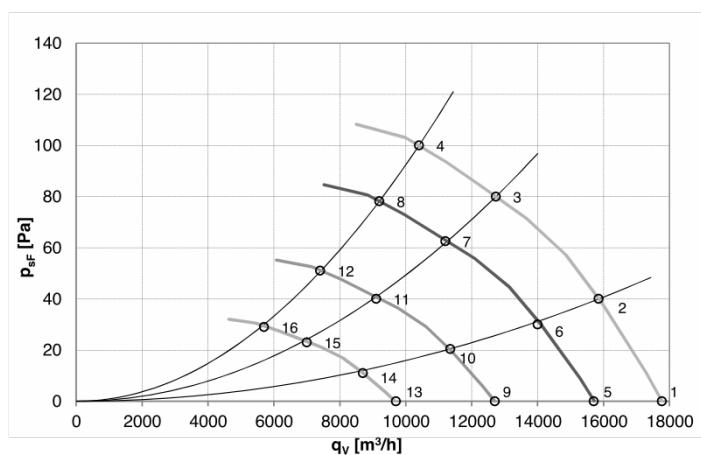

	U [V]	f [Hz]	n [RPM]	qv [m³/h]	P _{sF} [Pa]	P _e [W]	I [A]	L _{wA out} [dB (A)]	T _{a max} [°C]
1	400	50	735	17770	0	503	0,85	70	60
2	400	50	735	15850	40	612	1,02	66	60
3	400	50	735	12730	80	735	1,18	65	60
4	400	50	735	10400	100	802	1,36	68	60
5	400	50	650	15700	0	348	0,68	67	60
6	400	50	650	14000	30	421	0,80	63	60
7	400	50	650	11200	63	510	0,92	62	60
8	400	50	650	9200	78	554	0,93	65	60
9	400	50	525	12700	0	183	0,38	63	60
10	400	50	525	11350	20	225	0,35	59	60
11	400	50	525	9100	40	265	0,53	58	60
12	400	50	525	7400	51	292	0,57	61	60
13	400	50	400	9700	0	81	0,21	57	60
14	400	50	400	8700	11	97	0,24	53	60
15	400	50	400	7000	23	117	0,27	52	60
16	400	50	400	5700	29	128	0,28	55	60

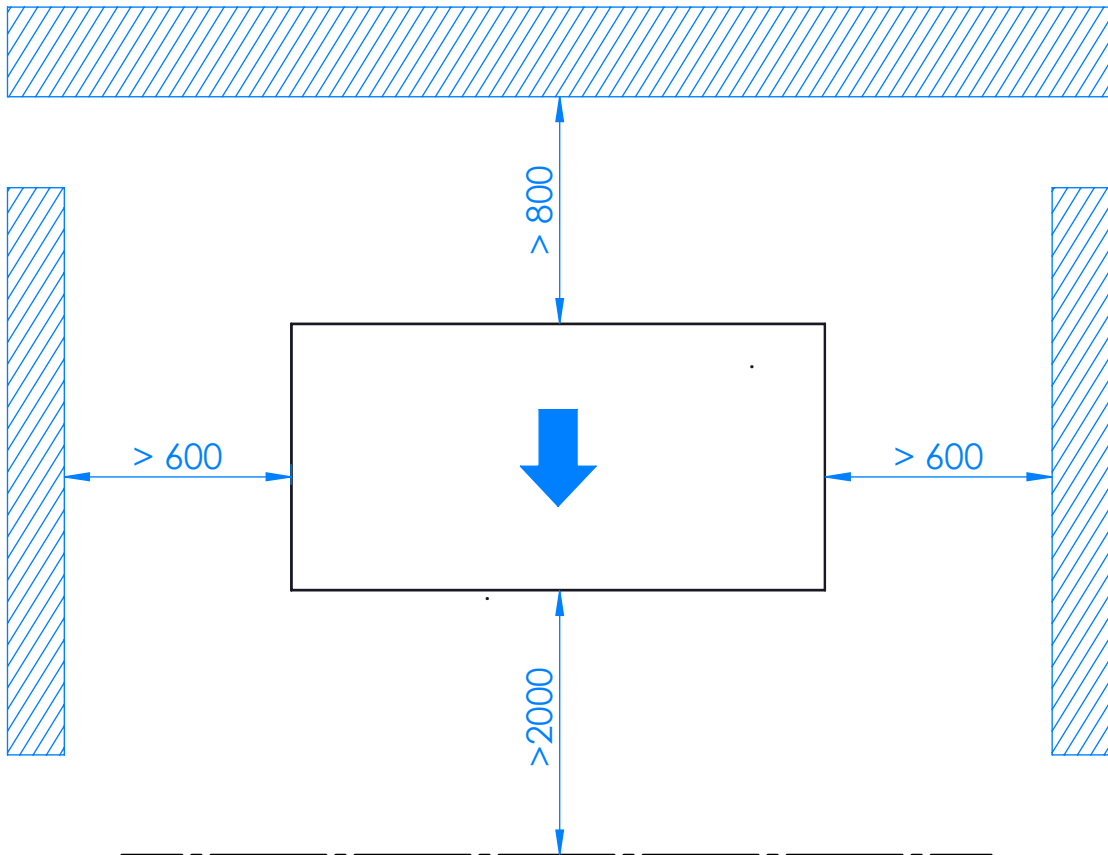
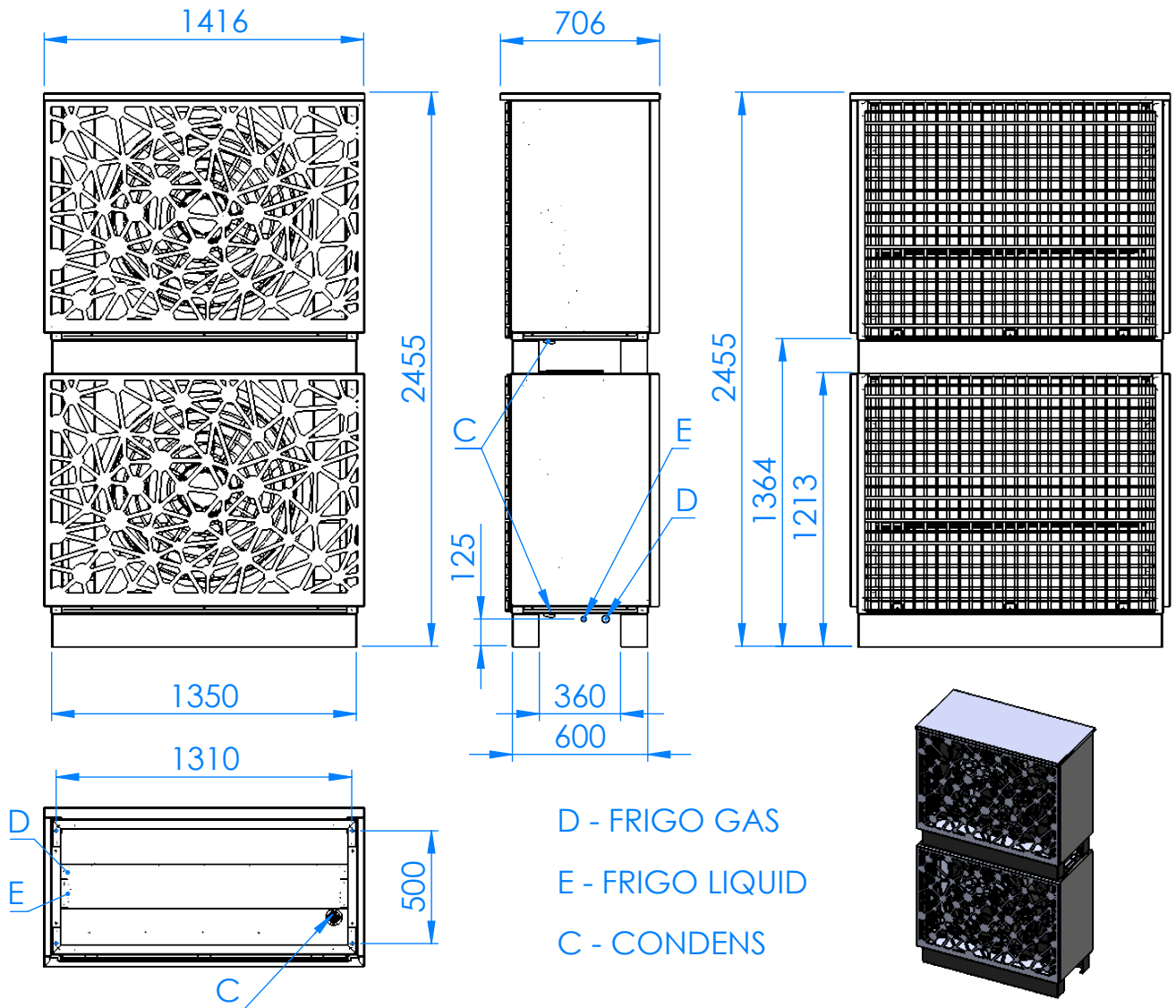

WAMAK AW 40 EVI - Split unit variant: VOII-1200-2LOW-DUCT

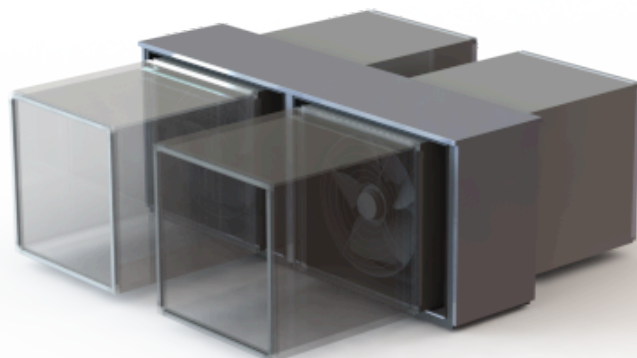

Enclosure type: VOII-1200-2LOW-DUCT			Evaporator	
Article	WAVID12L		Type	Cu-coil /Al-fin "
Basic dimensions	Height [mm]	1240	Port size	5/8" - 1.1/8" "
	Width [mm]	2850	Heat transfer medium	Air
	Length [mm]	710	Volume flow - Air [m3/h]	13200
Weight [kg]	300		Internal pressure drop - Air [kPa]	0.024
Colour	Gray		Temperature difference - Air	7 K
Enclosure IP Class	IP44		Expansion valve	EEV
Fan	800 mm			
Number of fans	2		Fan mounting position	Horizontal axis
Fan motor type	EC		Fan type	Axial
Fan nominal current [A]	1.35		Fan power supply [V/Hz]	3~ 400/50
Minimal fan power input [Watt]	81		Maximal fan power input [Watt]	802

Acoustic power Lw

62.5 dB(A)

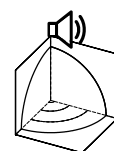
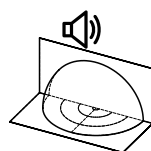
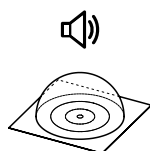

Distance [m]	1				5				10				15			
	1	5	10	15	1	5	10	15	1	5	10	15	1	5	10	15
Acoustic pressure Lp [dB(A)]	57.5	43.5	37.5	34	60.5	46.5	40.5	37	54.5	40.5	34.5	31				

EC Fan 800mm

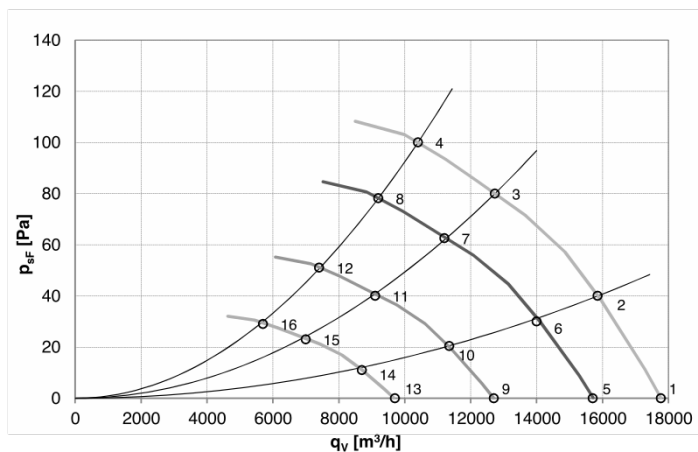

	U [V]	f [Hz]	n [RPM]	qv [m³/h]	PstF [Pa]	Pe [W]	I [A]	LwA out [dB (A)]	Ta max [°C]
1	400	50	735	17770	0	503	0,85	70	60
2	400	50	735	15850	40	612	1,02	66	60
3	400	50	735	12730	80	735	1,18	65	60
4	400	50	735	10400	100	802	1,36	68	60
5	400	50	650	15700	0	348	0,68	67	60
6	400	50	650	14000	30	421	0,80	63	60
7	400	50	650	11200	63	510	0,92	62	60
8	400	50	650	9200	78	554	0,93	65	60
9	400	50	525	12700	0	183	0,38	63	60
10	400	50	525	11350	20	225	0,35	59	60
11	400	50	525	9100	40	265	0,53	58	60
12	400	50	525	7400	51	292	0,57	61	60
13	400	50	400	9700	0	81	0,21	57	60
14	400	50	400	8700	11	97	0,24	53	60
15	400	50	400	7000	23	117	0,27	52	60
16	400	50	400	5700	29	128	0,28	55	60

WAMAK AW 40 EVI - Split unit variant: VOII-1200-2HIGH-DUCT



Enclosure type: VOII-1200-2HIGH-DUCT			Evaporator	
Article	WAVID12H		Type	Cu-coil /Al-fin "
Basic dimensions	Height [mm]	2450	Port size	5/8" - 1.1/8" "
	Width [mm]	1420	Heat transfer medium	Air
	Length [mm]	710	Volume flow - Air [m3/h]	13200
Weight [kg]	300		Internal pressure drop - Air [kPa]	0.024
Colour	Gray		Temperature difference - Air	7 K
Enclosure IP Class	IP44		Expansion valve	EEV
Fan	800 mm			
Number of fans	2		Fan mounting position	Horizontal axis
Fan motor type	EC		Fan type	Axial
Fan nominal current [A]	1.35		Fan power supply [V/Hz]	3~ 400/50
Minimal fan power input [Watt]	81		Maximal fan power input [Watt]	802

Acoustic power L_w

62.5 dB(A)

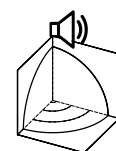
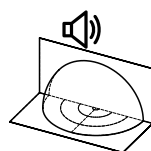
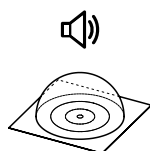

Distance [m]	1				5				10				15			
	1	5	10	15	1	5	10	15	1	5	10	15	1	5	10	15
Acoustic pressure L _p [dB(A)]	57.5	43.5	37.5	34	60.5	46.5	40.5	37	54.5	40.5	34.5	31				

EC Fan 800mm

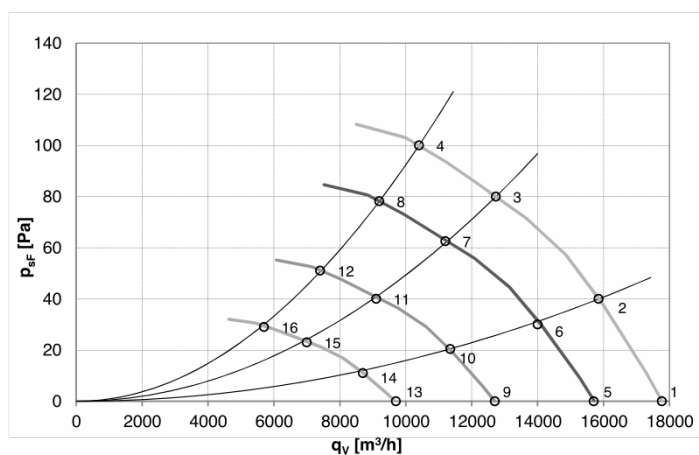

	U [V]	f [Hz]	n [RPM]	q _v [m ³ /h]	P _{sF} [Pa]	P _e [W]	I [A]	L _{WA out} [dB (A)]	T _{a max} [°C]
1	400	50	735	17770	0	503	0,85	70	60
2	400	50	735	15850	40	612	1,02	66	60
3	400	50	735	12730	80	735	1,18	65	60
4	400	50	735	10400	100	802	1,36	68	60
5	400	50	650	15700	0	348	0,68	67	60
6	400	50	650	14000	30	421	0,80	63	60
7	400	50	650	11200	63	510	0,92	62	60
8	400	50	650	9200	78	554	0,93	65	60
9	400	50	525	12700	0	183	0,38	63	60
10	400	50	525	11350	20	225	0,35	59	60
11	400	50	525	9100	40	265	0,53	58	60
12	400	50	525	7400	51	292	0,57	61	60
13	400	50	400	9700	0	81	0,21	57	60
14	400	50	400	8700	11	97	0,24	53	60
15	400	50	400	7000	23	117	0,27	52	60
16	400	50	400	5700	29	128	0,28	55	60

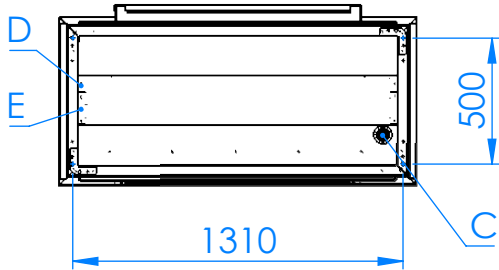
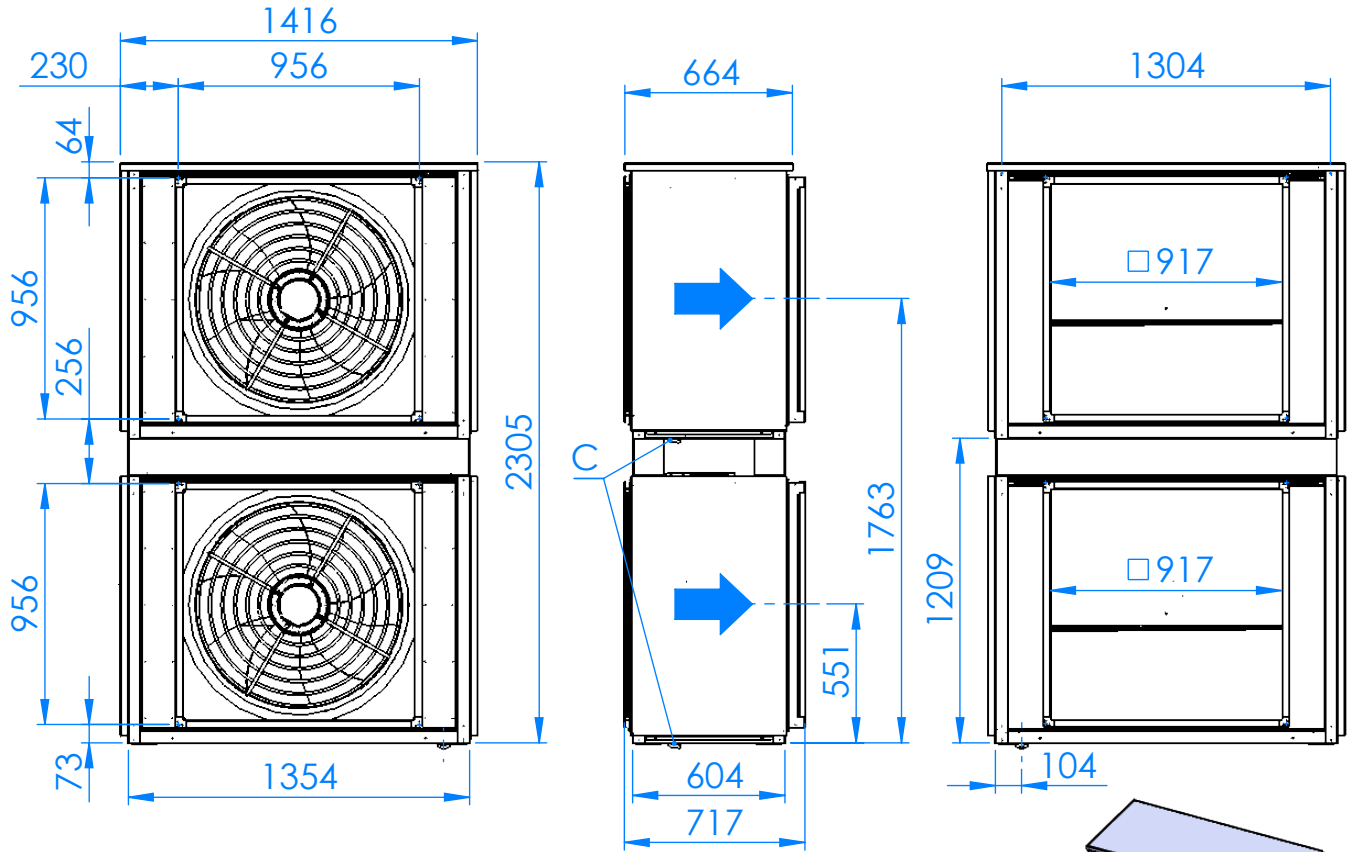

D - FRIGO GAS
 E - FRIGO LIQUID
 C - CONDENS

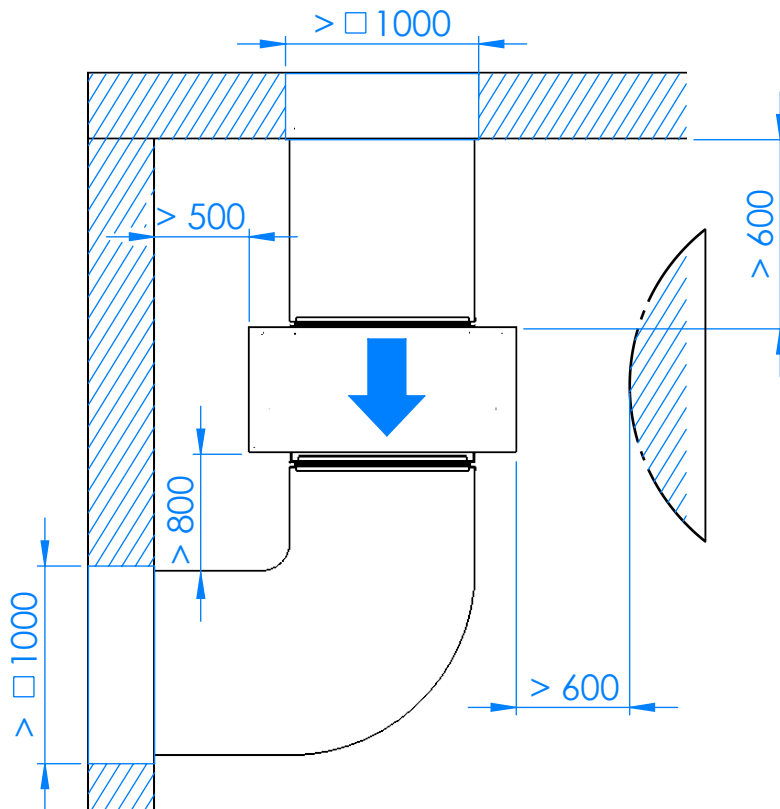
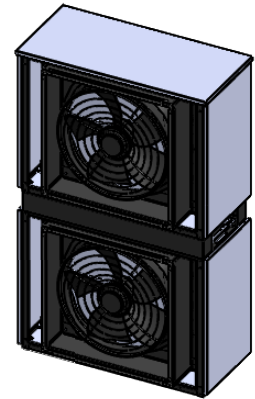

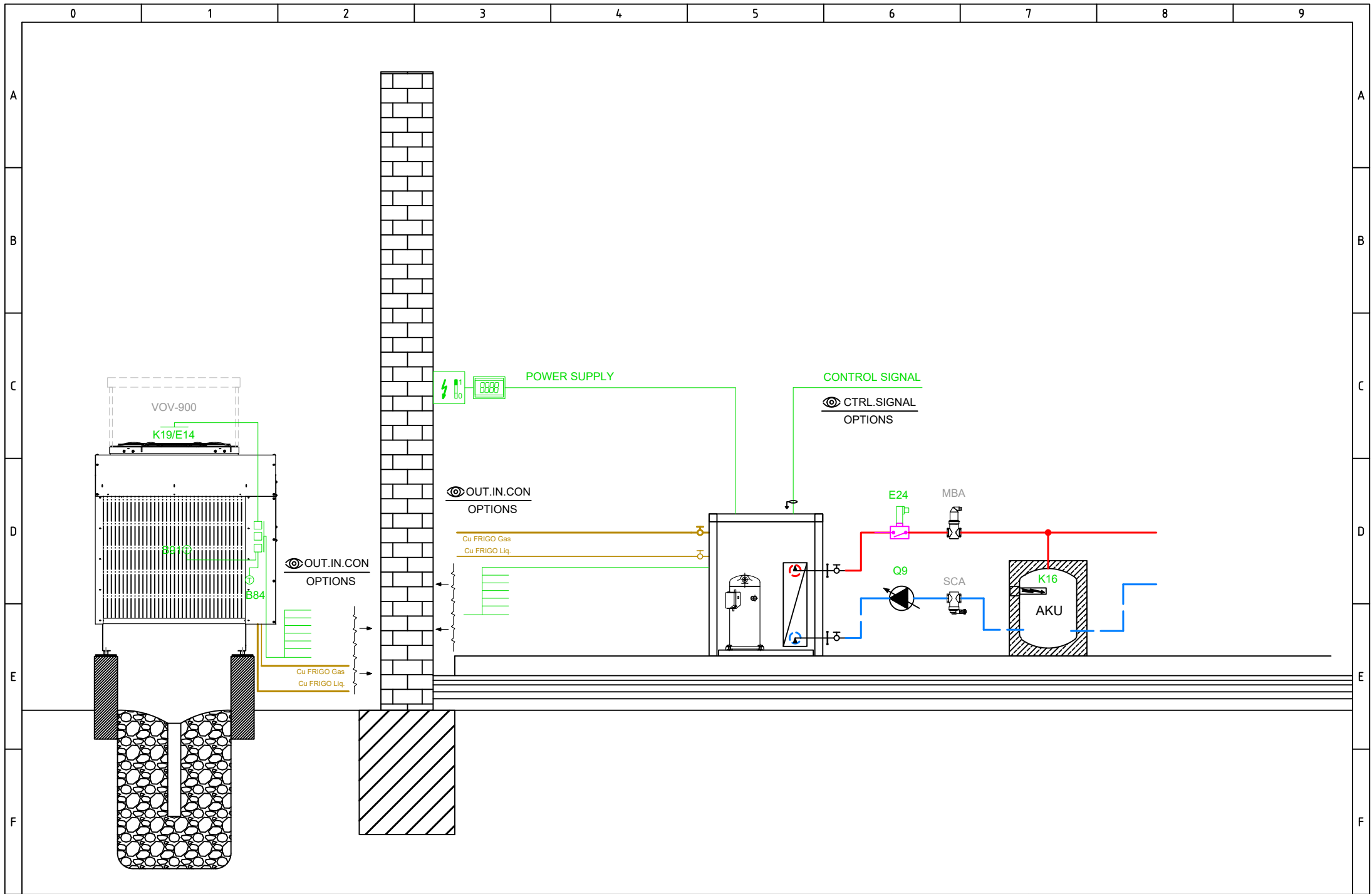

FACTORY SETTINGS

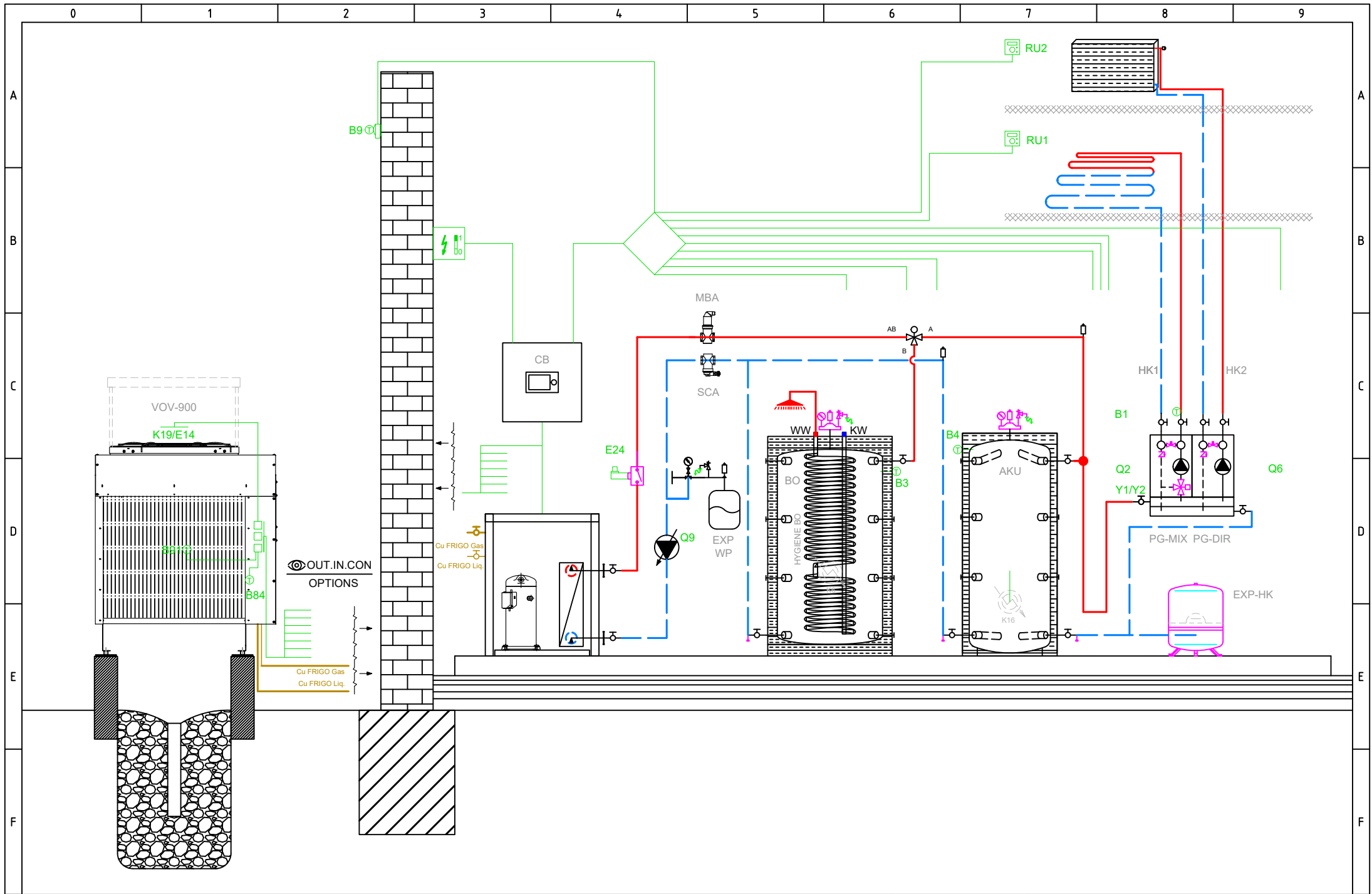

BASIC APPLICATION

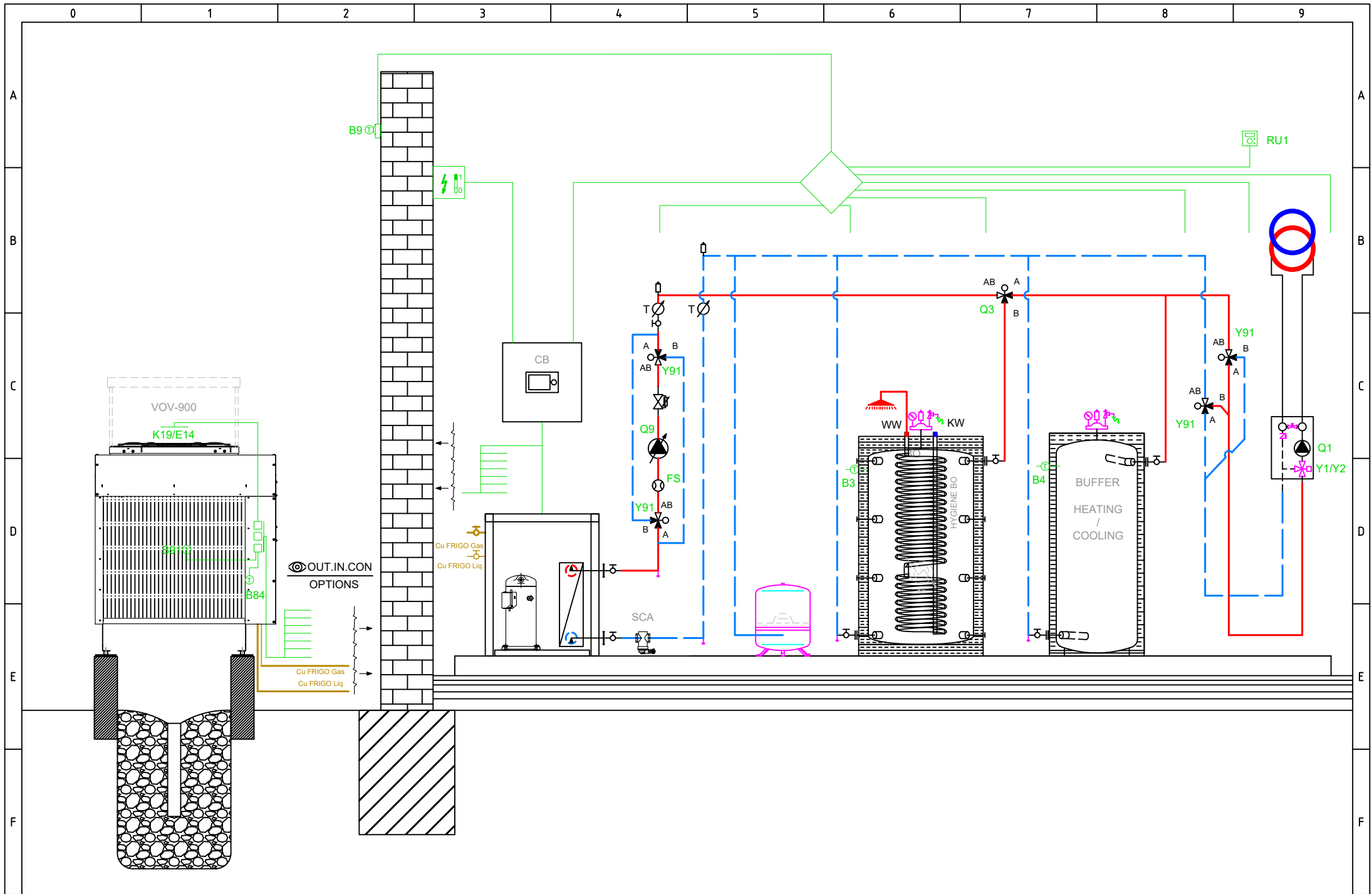

OPTIONAL APPLICATION



Main power supply 230V / 50 Hz
Ground
Neutral conductor

- E10 High-pressure switch E10
- E11 Overload compressor 1 E11
- E14 Overload source E14
- E24 Flow switch consumers E24
- K82 Valve EVI K82

K40 Crankcase heater K40

- L Phase 230V
- K1 Compressor stage 1 K1
- Y22 Process revers valve Y22

Q9 Condenser pump Q9

X10	1	L
X10	1	PE
X10	1	N
X11	1	EX1
X11	1	EX2
X11	1	EX3
X11	1	EX4
X12	1	QX1
X12	1	N
X12	1	QX2
X12	1	QX2i
X12	1	N
X12	1	FX3
X12	1	QX3
X15	1	QX4
X15	1	QX4i
X15	1	N
X15	1	QX5
X15	1	N
X15	1	ZX6
X15	1	N
X86	1	GX1
X86	1	H3
X86	1	M
X86	1	H1
X86	1	G+
X86	1	M
X86	1	BSB



Total: max 6A
1 x QX...: max 2A

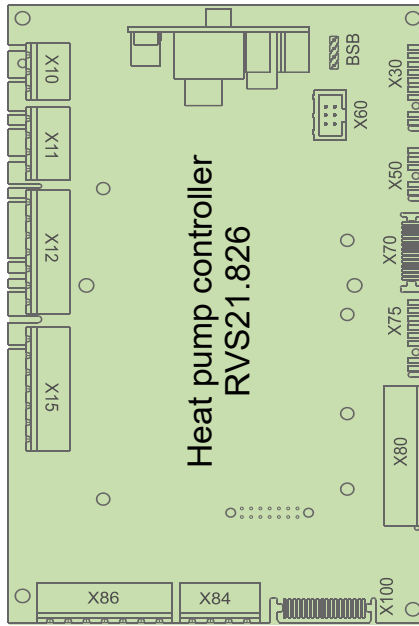

BSB
X30
X60
X50
X70

- BSB Connection service tool (OCI700)
- X30 Operating unit (HMI) AVS37.xxx
- X60 Modbus clip-in OCI351.01
- X50 Extension module AVS75.xxx
- X70 LPB clip-in

D1
D2
D3
UX3
M
DI6
DI7
M

- D1 Digital output 1 Heating
- D2 Digital output 2 Cooling
- D3 Digital output 3 HP On/Off

- DI6 Digital input 6 Defrosting
- DI7 Digital input 7 Alarm

BX1
M
BX2
M
UX1
M
UX2
M

- B91 Source inlet sensor B91
- B84 Source outl sens B92/B84
- K19 Fan K19
- 0..10 V Signal
- Q9 Condenser pump Q9
- PWM Signal

BX3
M
BX4
M

- B71 HP return sensor B71
- B9 Outside sensor B9

Main power supply 230V / 50 Hz
Ground
Neutral conductor

K10 Alarm output K10

V81 EEV evaporator V81

X10	1	L
X10	1	PE
X10	1	N
X110	1	QX31
X110	1	QX32
X110	1	N
X110	1	QX33
X110	1	N
X110	1	ZX34
X110	1	N
X115	1	QX35
X115	1	QX35i
X115	1	N

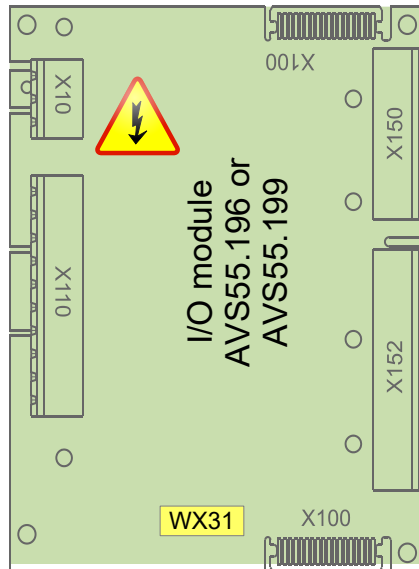

BSB
M
G+
H31
M
H32
GX1
H33
M
BX31
M
BX32
M
BX33
M
BX34
M

- 5 V/12 V for active sensors
- Flow measurement 10V
- Low pressure 0..10V
- 5 V/12 V for active sensors
- High pressure 0..10V
- B21 HP flow sensor B21
- B81 Hot-gas sensor B81
- B85 Suction gas sensor B85
- B83 Refrig sensor liquid B83

- AVS75.390
- AVS75.391
- AVS75.370

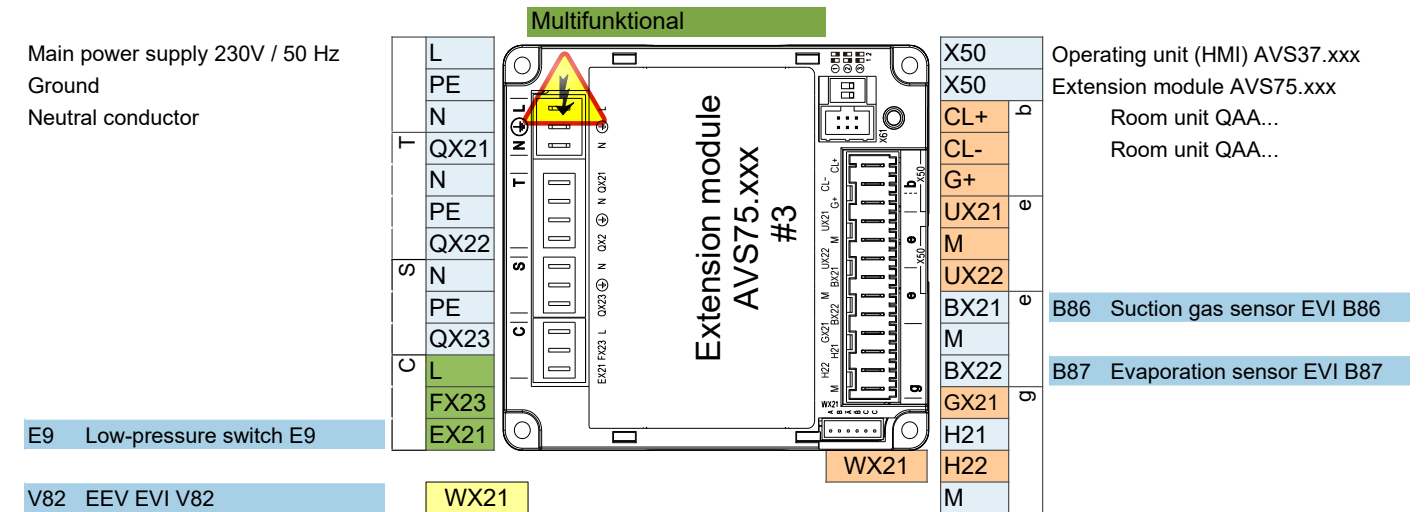
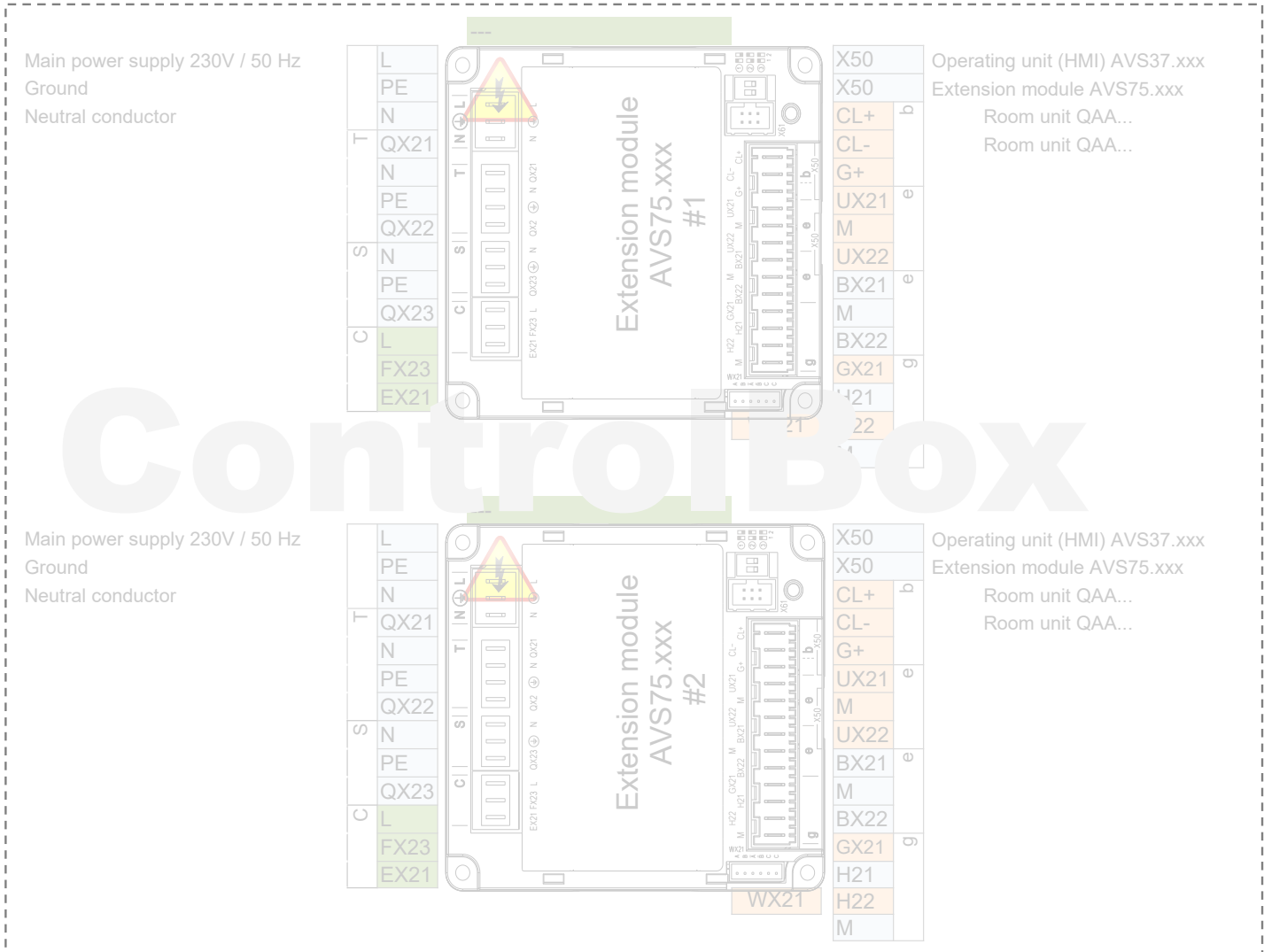

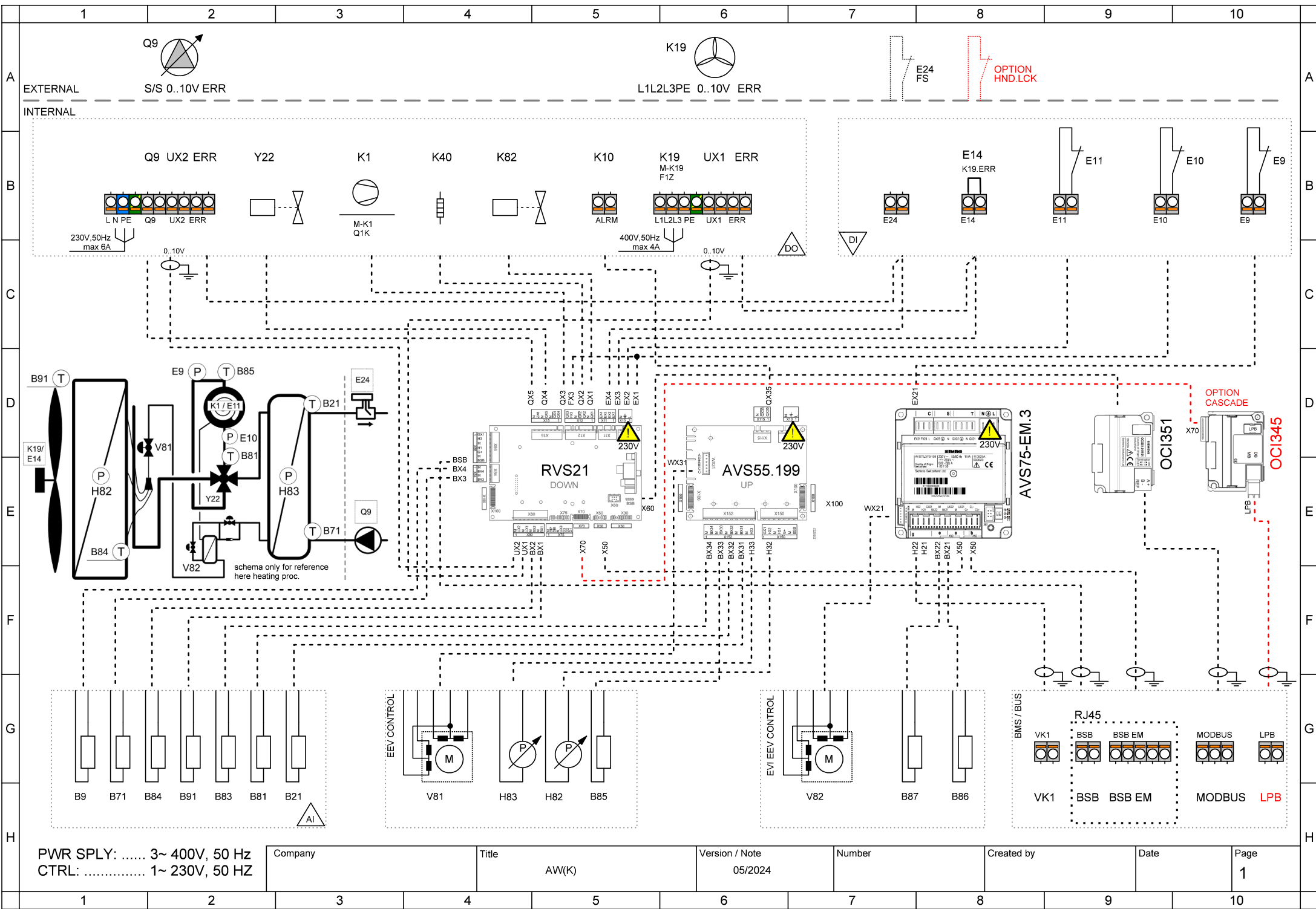

PWR SPLY: 3~ 400V, 50 Hz
 CTRL: 1~ 230V, 50 HZ

Company	Title	Version / Note	Number	Created by	Date	Page
	AW(K)	05/2024				1

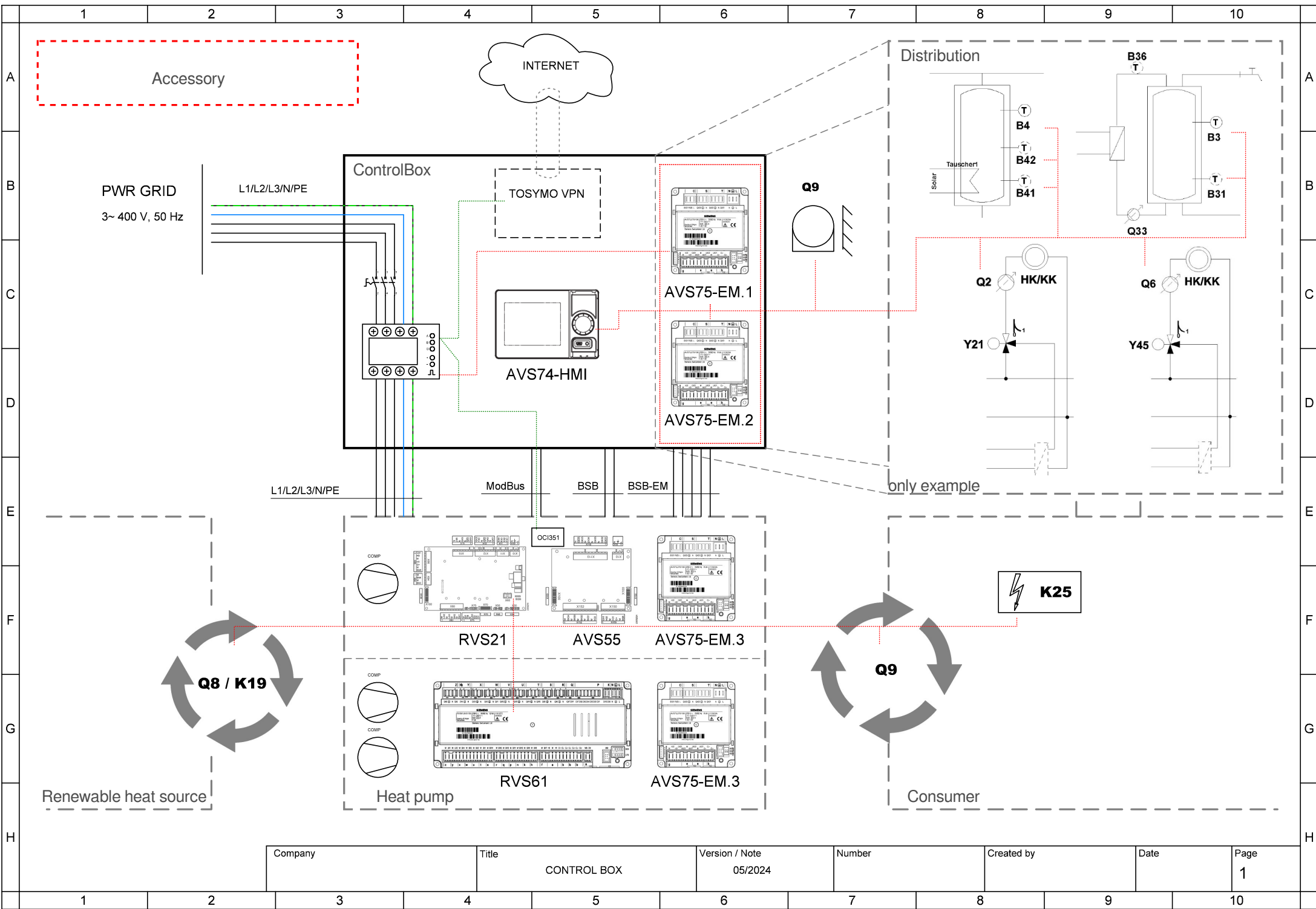

Company	Title	Version / Note	Number	Created by	Date	Page
	CONTROL BOX	05/2024				1



Company	Title	Version / Note	Number	Created by	Date	Page
	CONTROL BOX	05/2024				2



Company	Title	Version / Note	Number	Created by	Date	Page
	CONTROL BOX	05/2024				3



- AVS75.390
- AVS75.391
- AVS75.370

- AVS75.370**
 Main power supply 230V / 50 Hz
 Ground
 Neutral conductor
Y1 Mixing valve Open

Y2 Mixing valve Close

Q2 Heat circuit pump HC1 Q2

L Phase 230V
E61 Smart grid E61

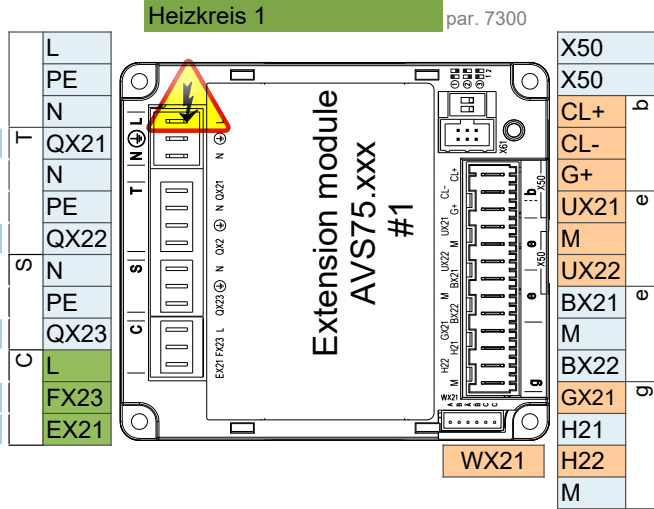

- AVS75.370**
 Main power supply 230V / 50 Hz
 Ground
 Neutral conductor
Q3 DHW ctrl elem Q3

K6 El imm heater DHW K6

Q6 Heat circuit pump HC2 Q6

L Phase 230V
E62 Smart grid E62

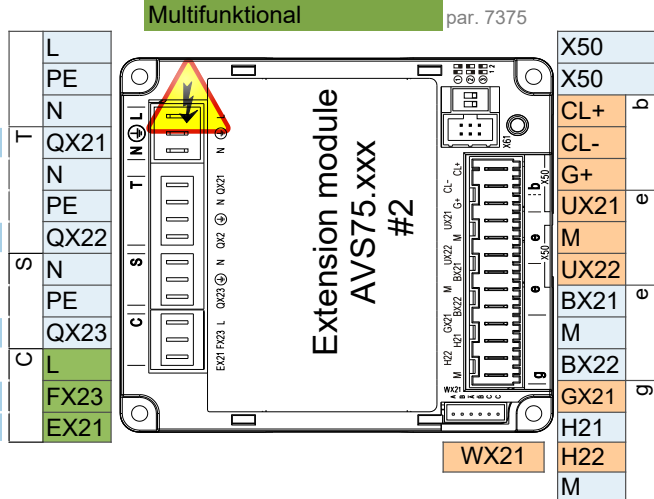

- Main power supply 230V / 50 Hz
 Ground
 Neutral conductor

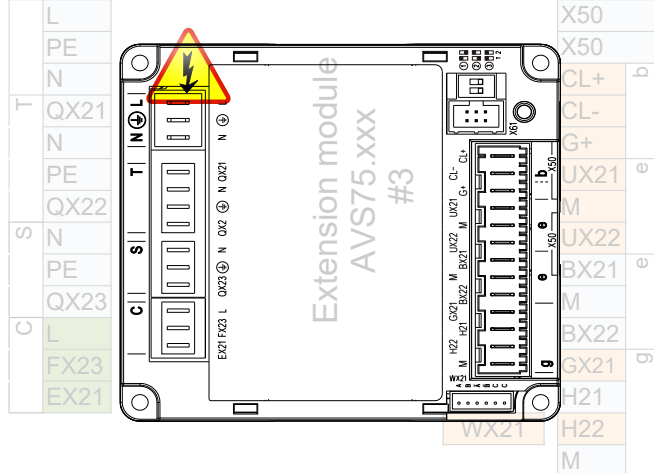

Attention: Extension module 3 is inside the heat pump

Control connection options

1 ControlBox

ControlBox, with two built-in extension modules, enables numerous options for application control on the consumer side behind the heat pump. For more, see the ControlBox schematic and the application diagrams sheet.

2 Fix flow temperature setpoint - On / Off dry (potential free) contact

2 wire shielded cable 2 x 0.5 mm² - Setpoint = 45°C (editable by param. 1859)

Connection terminal - see wiring diagram

3 Analog 0..10V flow temperature setpoint control

2 wire shielded cable 2 x 0.5 mm² - Setpoint: 0V = 16°C ~ 10V = 60°C (editable in parameter set)

Connection terminal - see wiring diagram

4 ModBus RTU communication command

3 wire shielded cable min. 3 x 0.25mm²

For ModBus mapping table contact technical support

5 MQTT IoT communication protocol

For more information contact technical support