

## Grundlegende Leistungsdaten - WAMAK AWK 27 EVI

Heizen - EN 14511		
Wärmeleistung [kW]	A7 / W35	29.0
	A2 / W35	24.7
	A-7 / W34	20.3
Leistungsaufnahme [kW]	A7 / W35	6.4
	A2 / W35	6.4
	A-7 / W34	6.3
Leistungszahl Heizen [COP]	A7 / W35	4.57
	A2 / W35	3.83
	A-7 / W34	3.22
Jahreszeitbedingte Raumheizungs-Energieeffizienz - SCOP EN 14825		
Klimazone Durchschnitt / Niedrigtemp. [35°C]	SCOP	4.37
	$\eta$ [%]	174.7
	Label	A+++
	Qhe [ kWh ]	47518.0
	Pdesignh [ kW ]	23.0
	Tbivalent [ °C ]	-7
Kühlung		
Kühlleistung - [kW]	A35 / W23-18	28.4
	A25 / W23-18	30.0
	A35 / W12-7	20.9
	A25 / W12-7	20.9
Jahreszeitbedingte Raumkühlungs-Energieeffizienz - SEER EN 14825		
[ W 23 / 18°C ]	SEER	4.61
	Qce [ kWh ]	12540.0
	$\eta_c$ [%]	184.3
Schall EN 12102		
Schalleistungspegel - Lw	dB(A)	65.7
Schalldruckpegel - Lp	1 m dB(A)	57.7
	5 m dB(A)	43.7
	10 m dB(A)	37.7
Mechanische und Betriebs-Informationen		
Verdichterbauart (3~ 400/50)	SCROLL / 1 /	Ein/Aus
Kältemittel	R410A (GWP - 2088)	7.9 kg
Einsatzgrenze Heizungswasser - (min / max ) [°C]		25 / <b>65</b>
Einsatzgrenze Wärmequelle - (min / max ) [°C]		<b>-22</b> / 40
Gewicht		510 kg

## Wichtigste technische Daten - WAMAK AWK 27 EVI

Gehäuse Bezeichnung		AWK-VOV900		Daten von Wärmeabgabe			
<b>Grundlegende Abmessungen</b>	Hohe [mm]	1250		Einsatzgrenze Heizungswasser	MAX [°C] 65		
	Breite [mm]	1380			MIN [°C] 25		
	Länge [mm]	1780		genauer siehe Betriebsgrenzendiagramm			
Gewicht [kg]	510		<b>Kondensator</b>	Anschlussdimension	2 "		
Gehäuse Farbe	Edelstahl			Bauart	BPHE		
Gehäuse IP Klasse	IP44			Anzahl	1		
<b>Kältekreis</b>				Material	AISI 316		
<b>Verdichter</b>	Bauart	Scroll		Maximaler Überdruck - Kältemittel [bar]	50		
	Leistungstufen	1		Maximaler Überdruck - Wasser [bar]	6		
	Ein/Aus			Prüfdruck [bar]	70		
	Leistungsfaktor Cosφ	0.69		Wärmeträger	Wasser		
	Wicklungswiderstand	1.24 Ohm		Volumenstrom @ dT 5K (nom) - Wasser [m3/h]	5.00		
Kältemittel		R410A		Interne Druckdifferenz - Wasser [kPa]	12		
	Menge	7.9 kg		Temperaturdifferenz @ 35°C (nom)	5 K		
	GWP	2088		@ 55°C	8 K		
	Sicherheitsklasse	A1		@ 65°C	10 K		
Kältemittelöl	POE RL32-3MAF			<b>Daten von Erneuerbarer Energiequelle</b>			
	Ölmenge	3.38 L		Einsatzgrenze Wärmequelle	MIN [°C] -22		
Maximaler Hochdruck - Kältemittel [bar]		50			MAX [°C] 40		
	PED Klasse	2		genauer siehe Betriebsgrenzendiagramm			
EVI - Dampfeinspritzung mit Economiser				<b>Verdampfer</b>	Bauart	Cu-coil /Al-fin	
APS System mit Flüssigkeitsunterkühlung					Anzahl	1	
Reversibler Betrieb (Kühlung)					Material	Cu/Al	
Reversible Abtauung mit Heissgas				Maximaler Überdruck - Kältemittel [bar]	29		
Plattentauscherschutz HG-BYPASS				Wärmeträger	Luft		
<b>Daten von Elektroanschluss</b>				Volumenstrom - Luft [m3/h]	9060		
Einspeisung [#~ V/Hz]	3~ 400/50			Interne Druckdifferenz - Luft [kPa]	0.023		
Strom	Nominal [A]	12.30		Temperaturdifferenz - Luft	7 K		
	Maximal [A]	21.00		Anzahl von Ventilatoren	1		
	Start [A]	32.12		Ventilator Durchmesser [mm]	800		
Sanftanlasser	-						
Hauptsicherung	C32						
<b>Steuerungssystem</b>							
Hauptregler	SIEMENS	RVS 21 AVS 55.199					
Erweiterungsmo dul	AVS75.3xx	AVS75.3xx	AVS75.372				
Bus Clip-In		LPB OCI347	Modbus OCI353				
Online-Verbindung		Web server OZW672	ToSyMo				
EEV Regelung	1 - EEV H/C						

\*\*\* mit Zubehör

# WAMAK AWK 27 EVI

## ErP (EU) No 811/2013: Technische Parameter für Wärmepumpen-Raumheizgeräte

Modell	AWK 27 EVI
Luft-Wasser-Wärmepumpe	ja
Sole/Wasser-Wärmepumpe	nein
Wasser/Wasser-Wärmepumpe	nein
Niedertemperatur-Wärmepumpe	nein
Ausgestattet mit einer Zusatzheizung	nein
Wärmepumpen-Kombi-Heizgerät	nein
Temperaturanwendung	niedrig (35 °C - 30 °C)
Klimaverhältnisse	durchschnittlich

Angabe	Symbol	Wert	Ein.	Angabe	Symbol	Wert	Ein.
Nennwärmeleistung bei Tdesignh	Prated	23.0	kW	Jahreszeitbedingte Raumheizungs-Energieeffizienz	$\eta_s$	174.7	%
Ausgewiesene Heizleistung für Teillast bei einer Innentemperatur von 20 °C und einer Außentemperatur von Tj				Deklarierte Leistungszahl oder Primärenergiekennzahl für Teillast bei einer Innentemperatur von 20 °C und einer Außentemperatur von Tj			
Tj = -7 °C	Pdh	20.3	kW	Tj = -7 °C	COPd	3.22	-
Tj = +2 °C	Pdh	24.6	kW	Tj = +2 °C	COPd	4.3	-
Tj = +7 °C	Pdh	29.0	kW	Tj = +7 °C	COPd	5.6	-
Tj = +12 °C	Pdh	33.7	kW	Tj = +12 °C	COPd	7.5	-
Tj = bivalente Temperatur	Pdh	19.7	kW	Tj = bivalente Temperatur	COPd	3.1	-
Tj = Betriebsgrenztemperatur	Pdh	13.9	kW	Tj = Betriebsgrenztemperatur	COPd	2.2	-
Bivalente Temperatur	Tbiv	-7	°C	Tj = Betriebsgrenztemperatur	TOL	-22	°C
<b>Stromverbrauch in anderen Modi als dem aktiven Modus</b>				Betriebsgrenztemperatur des Heizwassers			
Aus-Zustand	Poff	0.040	kW	Zusatzheizung			
Thermostat-Aus-Modus	Pto	0.010	kW	Nennwärmeleistung	Psup	10.5	kW
Standby-Betrieb	Psb	0.010	kW	Art der Energiezufuhr			
Betriebsart Kurbelwannenheizung	Pck	0.050	kW	elektrisch			
<b>Sonstige Angaben</b>				Für Luft/Wasser-Wärmepumpen: Nennluftvolumenstrom, Außenbereich			
Leistungsregelung		fest		Für Wasser- oder Sole/Wasser-Wärmepumpen: Nenndurchfluss der Sole oder des Wassers, Wärmetauscher im Freien			
Schalleistungspegel							
in Innenräumen	Lwa	---	dB				
im Freien	Lwa	66	dB				
Jährlicher Energieverbrauch	QHE	47518.0	kWh				

**Angaben zum Kontakt:** WAMAK, s.r.o., Orovnica 252, 96652, Orovnica, Slovakia, info@wamak.sk

# WAMAK AWK 27 EVI

## ErP (EU) No 811/2013: Technische Parameter für Wärmepumpen-Raumheizgeräte

Modell	AWK 27 EVI
Luft-Wasser-Wärmepumpe	ja
Sole/Wasser-Wärmepumpe	nein
Wasser/Wasser-Wärmepumpe	nein
Niedertemperatur-Wärmepumpe	nein
Ausgestattet mit einer Zusatzheizung	nein
Wärmepumpen-Kombi-Heizgerät	nein
Temperaturanwendung	mittel (55 °C - 47 °C)
Klimaverhältnisse	durchschnittlich

Angabe	Symbol	Wert	Ein.	Angabe	Symbol	Wert	Ein.
Nennwärmeleistung bei Tdesignh	Prated	24.0	kW	Jahreszeitbedingte Raumheizungs-Energieeffizienz	$\eta_s$	133.7	%
Ausgewiesene Heizleistung für Teillast bei einer Innentemperatur von 20 °C und einer Außentemperatur von Tj				Deklarierte Leistungszahl oder Primärenergiekennzahl für Teillast bei einer Innentemperatur von 20 °C und einer Außentemperatur von Tj			
Tj = -7 °C	Pdh	21.0	kW	Tj = -7 °C	COPd	2.16	-
Tj = +2 °C	Pdh	24.8	kW	Tj = +2 °C	COPd	3.3	-
Tj = +7 °C	Pdh	29.1	kW	Tj = +7 °C	COPd	4.5	-
Tj = +12 °C	Pdh	33.9	kW	Tj = +12 °C	COPd	6.3	-
Tj = bivalente Temperatur	Pdh	20.6	kW	Tj = bivalente Temperatur	COPd	2.0	-
Tj = Betriebsgrenztemperatur	Pdh	15.4	kW	Tj = Betriebsgrenztemperatur	COPd	1.5	-
Bivalente Temperatur	Tbiv	-7	°C	Tj = Betriebsgrenztemperatur	TOL	-22	°C
<b>Stromverbrauch in anderen Modi als dem aktiven Modus</b>				Betriebsgrenztemperatur des Heizwassers	WTOL	65	°C
Aus-Zustand	Poff	0.040	kW	<b>Zusatzheizung</b>			
Thermostat-Aus-Modus	Pto	0.010	kW	Nennwärmeleistung	Psup	10.5	kW
Standby-Betrieb	Psb	0.010	kW	Art der Energiezufuhr	elektrisch		
Betriebsart Kurbelwannenheizung	Pck	0.050	kW	<b>Sonstige Angaben</b>			
Leistungsregelung				fest			
Schalleistungspegel				Für Luft/Wasser-Wärmepumpen: Nennluftvolumenstrom, Außenbereich	-	9060	m <sup>3</sup> /h
in Innenräumen	Lwa	---	dB	Für Wasser- oder Sole/Wasser-Wärmepumpen: Nenndurchfluss der Sole oder des Wassers, Wärmetauscher im Freien	-	---	m <sup>3</sup> /h
im Freien	Lwa	66	dB				
Jährlicher Energieverbrauch	Q <sub>HE</sub>	49584.0	kWh				

**Angaben zum Kontakt:** WAMAK, s.r.o., Orovnica 252, 96652, Orovnica, Slovakia, info@wamak.sk



**ENERG** Y IIA  
 енергия - ενεργεια IE IA

**WAMAK**

AWK 27 EVI

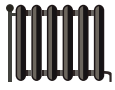

55 °C

35 °C

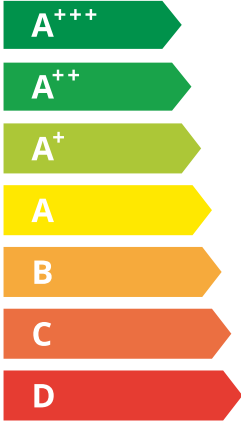

Speaker icon: --- dB

Microphone icon: 66 dB

■ 26	■ 24
■ 24	■ 23
■ 24	■ 22
kW	kW

2019

811/2013

AWK 27 EVI

ErP Data

	55 °C	35 °C
Energy class	<b>A++</b>	<b>A+++</b>
$\eta$ [%]	133.7	174.7
$P_{rated}$ [kW]	24	23
$Q_{HE}$ [kWh/y]	49584	47518
SCOP [-]	3.34	4.37
$T_{bivalent}$ [°C]	-7	-7

CONTROLLER



+ QAA55/75 class VII 3.5% ↓  
 - QAA55/75 class III 1.5% ↓

Heizleistung Daten

Version: v2024.004-AW

Klimazone Durchschnitt / Niedrigtemp. [35°C]

ZHI27K1P-TFD\_R410A\_1\_AW

Betriebsbedingungen		Qh	P	COP
1	A7 / W30-35	29.0	6.4	4.57
2	A2 / W35	24.7	6.4	3.83
3	A-22 / W35	13.9	6.4	2.19
A	A-7 / W34	20.3	6.3	3.22
B	A2 / W30	24.6	5.7	4.29
C	A7 / W27	29.0	5.2	5.55
D	A12 / W24	33.7	4.5	7.48
E	A-10 / W35	19.7	6.4	3.06
F	A-7 / W34	20.3	6.3	3.22

SCOP DATA EN 14825:2018	
<b>Klimazone Durchschnitt / Niedrigtemp. [35°C]</b>	
SCOPon	4.51
SCOPnet	4.55
SCOP	4.37
η [%]	174.74
Label	A+++
Qh [ kWh ]	47518.00
Pdesignh [ kW ]	23.0
Tbivalent [ °C ]	-7.00

Klimazone Durchschnitt / Mitteltemp. [55°C]

Betriebsbedingungen		Qh	P	COP
1	A7 / W47-55	29.3	10.5	2.80
2	A2 / W55	25.2	10.5	2.41
3	A-22 / W55	15.4	9.8	1.46
A	A-7 / W52	21.0	9.7	2.16
B	A2 / W42	24.8	7.6	3.27
C	A7 / W36	29.1	6.5	4.46
D	A12 / W30	33.9	5.4	6.29
E	A-10 / W55	20.6	10.5	1.97
F	A-7 / W55	21.2	10.5	2.02

SCOP DATA EN 14825:2018	
<b>Klimazone Durchschnitt / Mitteltemp. [55°C]</b>	
SCOPon	3.42
SCOPnet	3.45
SCOP	3.34
η [%]	133.68
Label	A++
Qh [ kWh ]	49584.00
Pdesignh [ kW ]	24.0
Tbivalent [ °C ]	-7.00

Kühlleistung Daten

Niedrigtemperatur Kühlung W 12 / 7°C

Betriebsbedingungen		Qc	P	EER
A	A35 / W12-7	20.9	7.7	2.70
B	A30 / W12-7	21.7	6.9	3.16
C	A25 / W12-7	22.3	6.1	3.67
D	A20 / W12-7	22.9	5.4	4.24

SEER DATA EN 14825:2018 [ W 12 / 7°C ]	
SEERon	3.56
SEER	3.46
Qc [ kWh ]	12540.00
η [%]	138.31

Flächenkühlung W 23 / 18°C

Betriebsbedingungen		Qc	P	EER
A	A35 / W23-18	28.4	7.7	3.67
B	A30 / W23-18	29.3	6.1	4.26
C	A25 / W23-18	30.0	5.4	4.93
D	A20 / W23-18	30.7	4.6	5.68

SEER DATA EN 14825:2018 [ W 23 / 18°C ]	
SEERon	4.80
SEER	4.61
Qc [ kWh ]	12540.00
η [%]	184.29

Leistungslinien - Heizen

- Qh-nom-35    — Qh-min-35    - - - Qh-max-65    — Qh-nom-45    — Qh-nom-55
- Qh-nom-65    — Pratedh-35    — Pratedh-55

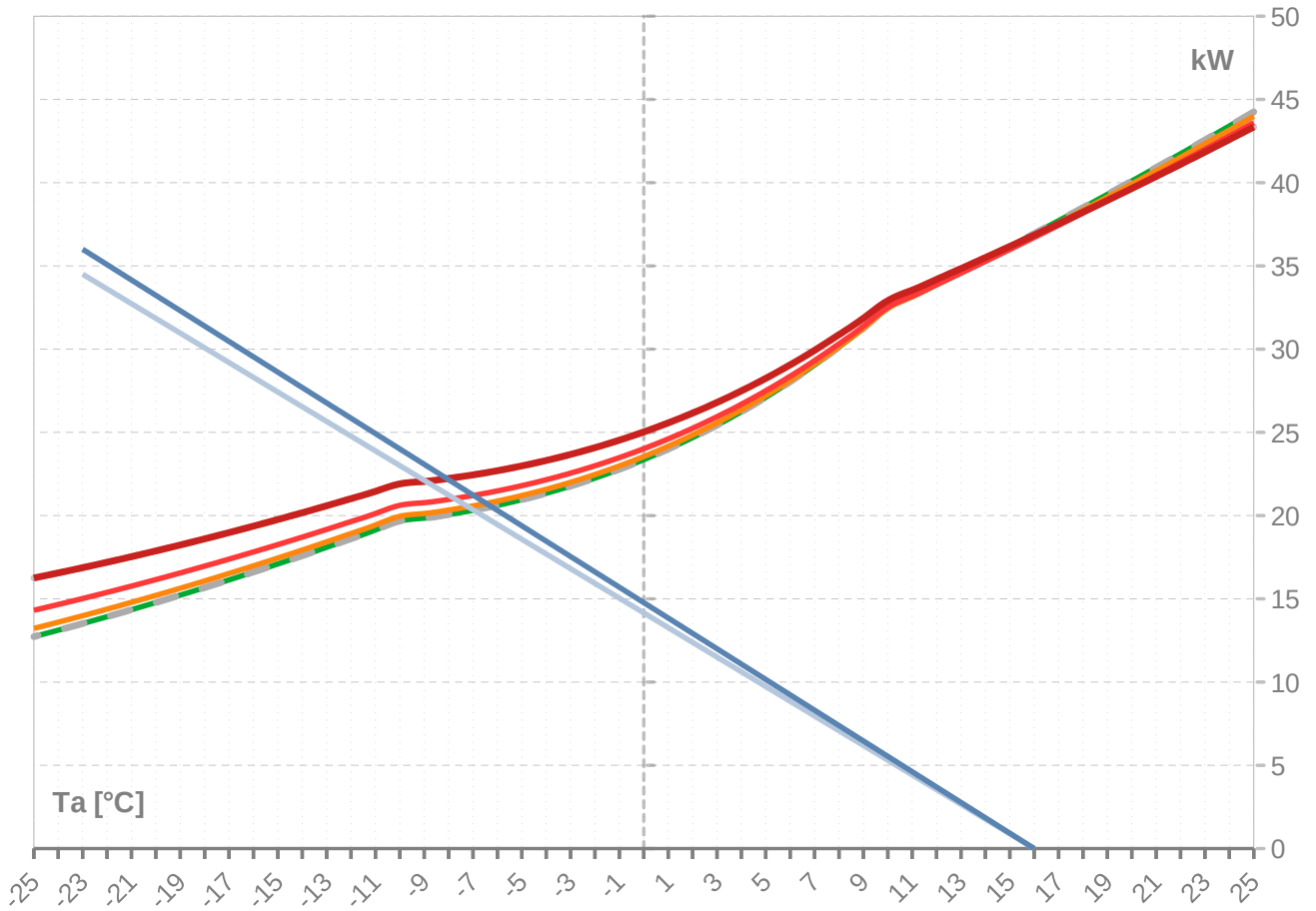

Leistungslinien - Kühlen

- Pratedc    — Qc-12/7    — Qc-23/18

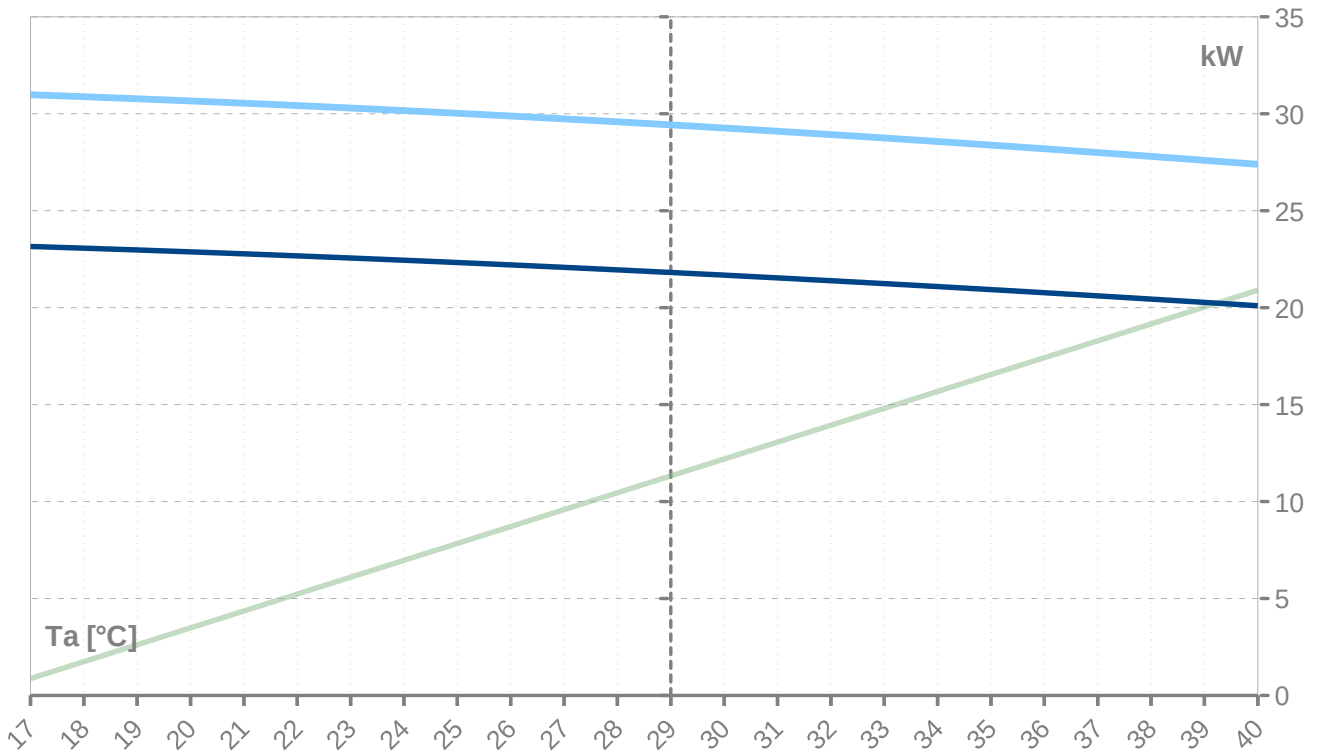

Th [°C]		35 °C								
Ta [°C]	Qh nom [kW]	Qh min [kW]	Qh max [kW]	Pin nom [kW]	Pin-min [kW]	Pin-max [kW]	COP kW / kW	I nom [A]	I min [A]	I max [A]
25	<b>37.7</b>	37.7		<b>6.0</b>	6.0		<b>6.34</b>	11.9	11.9	
24	<b>37.7</b>	37.7		<b>6.0</b>	6.0		<b>6.34</b>	11.9	11.9	
23	<b>37.7</b>	37.7		<b>6.0</b>	6.0		<b>6.34</b>	11.9	11.9	
22	<b>37.7</b>	37.7		<b>6.0</b>	6.0		<b>6.34</b>	11.9	11.9	
21	<b>37.7</b>	37.7		<b>6.0</b>	6.0		<b>6.34</b>	11.9	11.9	
20	<b>37.7</b>	37.7		<b>6.0</b>	6.0		<b>6.34</b>	11.9	11.9	
19	<b>37.7</b>	37.7		<b>6.0</b>	6.0		<b>6.34</b>	11.9	11.9	
18	<b>37.7</b>	37.7		<b>6.0</b>	6.0		<b>6.34</b>	11.9	11.9	
17	<b>37.7</b>	37.7		<b>6.0</b>	6.0		<b>6.34</b>	11.9	11.9	
16	<b>36.9</b>	36.9	36.9	<b>6.0</b>	6.0	6.0	<b>6.15</b>	12.0	12.0	12.0
15	<b>36.2</b>	36.2	36.2	<b>6.0</b>	6.0	6.0	<b>5.98</b>	12.0	12.0	12.0
14	<b>35.4</b>	35.4	35.4	<b>6.1</b>	6.1	6.1	<b>5.81</b>	12.0	12.0	12.0
13	<b>34.7</b>	34.7	34.7	<b>6.1</b>	6.1	6.1	<b>5.65</b>	12.1	12.1	12.1
12	<b>33.9</b>	33.9	33.9	<b>6.2</b>	6.2	6.2	<b>5.50</b>	12.1	12.1	12.1
11	<b>33.2</b>	33.2	33.2	<b>6.2</b>	6.2	6.2	<b>5.35</b>	12.1	12.1	12.1
10	<b>32.5</b>	32.5	32.5	<b>6.2</b>	6.2	6.2	<b>5.21</b>	12.2	12.2	12.2
9	<b>31.3</b>	31.3	31.3	<b>6.3</b>	6.3	6.3	<b>4.97</b>	12.2	12.2	12.2
8	<b>30.1</b>	30.1	30.1	<b>6.3</b>	6.3	6.3	<b>4.76</b>	12.3	12.3	12.3
7	<b>29.0</b>	29.0	29.0	<b>6.4</b>	6.4	6.4	<b>4.57</b>	12.3	12.3	12.3
6	<b>28.0</b>	28.0	28.0	<b>6.4</b>	6.4	6.4	<b>4.39</b>	12.3	12.3	12.3
5	<b>27.1</b>	27.1	27.1	<b>6.4</b>	6.4	6.4	<b>4.23</b>	12.4	12.4	12.4
4	<b>26.2</b>	26.2	26.2	<b>6.4</b>	6.4	6.4	<b>4.09</b>	12.4	12.4	12.4
3	<b>25.4</b>	25.4	25.4	<b>6.4</b>	6.4	6.4	<b>3.96</b>	12.4	12.4	12.4
2	<b>24.7</b>	24.7	24.7	<b>6.4</b>	6.4	6.4	<b>3.83</b>	12.4	12.4	12.4
1	<b>24.0</b>	24.0	24.0	<b>6.4</b>	6.4	6.4	<b>3.72</b>	12.4	12.4	12.4
0	<b>23.4</b>	23.4	23.4	<b>6.4</b>	6.4	6.4	<b>3.62</b>	12.4	12.4	12.4
-1	<b>22.8</b>	22.8	22.8	<b>6.4</b>	6.4	6.4	<b>3.53</b>	12.5	12.5	12.5
-2	<b>22.2</b>	22.2	22.2	<b>6.4</b>	6.4	6.4	<b>3.45</b>	12.5	12.5	12.5
-3	<b>21.8</b>	21.8	21.8	<b>6.4</b>	6.4	6.4	<b>3.38</b>	12.5	12.5	12.5
-4	<b>21.3</b>	21.3	21.3	<b>6.4</b>	6.4	6.4	<b>3.31</b>	12.5	12.5	12.5
-5	<b>21.0</b>	21.0	21.0	<b>6.4</b>	6.4	6.4	<b>3.25</b>	12.5	12.5	12.5
-6	<b>20.6</b>	20.6	20.6	<b>6.4</b>	6.4	6.4	<b>3.20</b>	12.5	12.5	12.5
-7	<b>20.3</b>	20.3	20.3	<b>6.4</b>	6.4	6.4	<b>3.15</b>	12.5	12.5	12.5
-8	<b>20.1</b>	20.1	20.1	<b>6.4</b>	6.4	6.4	<b>3.11</b>	12.5	12.5	12.5
-9	<b>19.8</b>	19.8	19.8	<b>6.4</b>	6.4	6.4	<b>3.08</b>	12.5	12.5	12.5
-10	<b>19.7</b>	19.7	19.7	<b>6.4</b>	6.4	6.4	<b>3.06</b>	12.5	12.5	12.5
-11	<b>19.1</b>	19.1	19.1	<b>6.4</b>	6.4	6.4	<b>2.97</b>	12.5	12.5	12.5
-12	<b>18.6</b>	18.6	18.6	<b>6.4</b>	6.4	6.4	<b>2.90</b>	12.5	12.5	12.5
-13	<b>18.1</b>	18.1	18.1	<b>6.4</b>	6.4	6.4	<b>2.82</b>	12.5	12.5	12.5
-14	<b>17.6</b>	17.6	17.6	<b>6.4</b>	6.4	6.4	<b>2.74</b>	12.4	12.4	12.4
-15	<b>17.1</b>	17.1	17.1	<b>6.4</b>	6.4	6.4	<b>2.67</b>	12.4	12.4	12.4
-16	<b>16.6</b>	16.6	16.6	<b>6.4</b>	6.4	6.4	<b>2.60</b>	12.4	12.4	12.4
-17	<b>16.1</b>	16.1	16.1	<b>6.4</b>	6.4	6.4	<b>2.52</b>	12.4	12.4	12.4
-18	<b>15.7</b>	15.7	15.7	<b>6.4</b>	6.4	6.4	<b>2.45</b>	12.4	12.4	12.4
-19	<b>15.2</b>	15.2	15.2	<b>6.4</b>	6.4	6.4	<b>2.39</b>	12.4	12.4	12.4
-20	<b>14.8</b>	14.8	14.8	<b>6.4</b>	6.4	6.4	<b>2.32</b>	12.4	12.4	12.4
-21	<b>14.3</b>	14.3	14.3	<b>6.4</b>	6.4	6.4	<b>2.25</b>	12.4	12.4	12.4
-22	<b>13.9</b>	13.9	13.9	<b>6.4</b>	6.4	6.4	<b>2.19</b>	12.3	12.3	12.3
-23	<b>13.5</b>	13.5	13.5	<b>6.4</b>	6.4	6.4	<b>2.13</b>	12.3	12.3	12.3
-24	<b>13.1</b>	13.1	13.1	<b>6.3</b>	6.3	6.3	<b>2.07</b>	12.3	12.3	12.3
-25	<b>12.7</b>	12.7	12.7	<b>6.3</b>	6.3	6.3	<b>2.01</b>	12.3	12.3	12.3

\* Achtung: Betriebsgrenzen beachten - nicht in Tabelle festgehalten

ZHI27K1P-TFD\_R410A\_1\_AW



Th [°C]		45 °C								
Ta [°C]	Qh nom [kW]	Qh min [kW]	Qh max [kW]	Pin nom [kW]	Pin-min [kW]	Pin-max [kW]	COP kW / kW	I nom [A]	I min [A]	I max [A]
25	<b>44.0</b>	44.0	44.0	<b>7.5</b>	7.5	7.5	<b>5.88</b>	13.5	13.5	13.5
24	<b>43.2</b>	43.2	43.2	<b>7.5</b>	7.5	7.5	<b>5.73</b>	13.5	13.5	13.5
23	<b>42.3</b>	42.3	42.3	<b>7.6</b>	7.6	7.6	<b>5.58</b>	13.6	13.6	13.6
22	<b>41.5</b>	41.5	41.5	<b>7.6</b>	7.6	7.6	<b>5.43</b>	13.6	13.6	13.6
21	<b>40.7</b>	40.7	40.7	<b>7.7</b>	7.7	7.7	<b>5.29</b>	13.7	13.7	13.7
20	<b>39.9</b>	39.9	39.9	<b>7.7</b>	7.7	7.7	<b>5.16</b>	13.7	13.7	13.7
19	<b>39.1</b>	39.1	39.1	<b>7.8</b>	7.8	7.8	<b>5.03</b>	13.8	13.8	13.8
18	<b>38.4</b>	38.4	38.4	<b>7.8</b>	7.8	7.8	<b>4.90</b>	13.8	13.8	13.8
17	<b>37.6</b>	37.6	37.6	<b>7.9</b>	7.9	7.9	<b>4.78</b>	13.9	13.9	13.9
16	<b>36.8</b>	36.8	36.8	<b>7.9</b>	7.9	7.9	<b>4.66</b>	13.9	13.9	13.9
15	<b>36.1</b>	36.1	36.1	<b>7.9</b>	7.9	7.9	<b>4.55</b>	14.0	14.0	14.0
14	<b>35.3</b>	35.3	35.3	<b>8.0</b>	8.0	8.0	<b>4.44</b>	14.0	14.0	14.0
13	<b>34.6</b>	34.6	34.6	<b>8.0</b>	8.0	8.0	<b>4.33</b>	14.0	14.0	14.0
12	<b>33.9</b>	33.9	33.9	<b>8.0</b>	8.0	8.0	<b>4.23</b>	14.1	14.1	14.1
11	<b>33.1</b>	33.1	33.1	<b>8.0</b>	8.0	8.0	<b>4.13</b>	14.1	14.1	14.1
10	<b>32.4</b>	32.4	32.4	<b>8.0</b>	8.0	8.0	<b>4.03</b>	14.1	14.1	14.1
9	<b>31.3</b>	31.3	31.3	<b>8.1</b>	8.1	8.1	<b>3.87</b>	14.2	14.2	14.2
8	<b>30.2</b>	30.2	30.2	<b>8.1</b>	8.1	8.1	<b>3.72</b>	14.2	14.2	14.2
7	<b>29.1</b>	29.1	29.1	<b>8.1</b>	8.1	8.1	<b>3.59</b>	14.2	14.2	14.2
6	<b>28.1</b>	28.1	28.1	<b>8.1</b>	8.1	8.1	<b>3.46</b>	14.3	14.3	14.3
5	<b>27.2</b>	27.2	27.2	<b>8.1</b>	8.1	8.1	<b>3.34</b>	14.3	14.3	14.3
4	<b>26.4</b>	26.4	26.4	<b>8.1</b>	8.1	8.1	<b>3.24</b>	14.3	14.3	14.3
3	<b>25.6</b>	25.6	25.6	<b>8.1</b>	8.1	8.1	<b>3.14</b>	14.3	14.3	14.3
2	<b>24.8</b>	24.8	24.8	<b>8.1</b>	8.1	8.1	<b>3.05</b>	14.3	14.3	14.3
1	<b>24.2</b>	24.2	24.2	<b>8.1</b>	8.1	8.1	<b>2.97</b>	14.3	14.3	14.3
0	<b>23.5</b>	23.5	23.5	<b>8.1</b>	8.1	8.1	<b>2.89</b>	14.3	14.3	14.3
-1	<b>23.0</b>	23.0	23.0	<b>8.1</b>	8.1	8.1	<b>2.82</b>	14.3	14.3	14.3
-2	<b>22.5</b>	22.5	22.5	<b>8.1</b>	8.1	8.1	<b>2.76</b>	14.3	14.3	14.3
-3	<b>22.0</b>	22.0	22.0	<b>8.1</b>	8.1	8.1	<b>2.70</b>	14.3	14.3	14.3
-4	<b>21.6</b>	21.6	21.6	<b>8.1</b>	8.1	8.1	<b>2.65</b>	14.3	14.3	14.3
-5	<b>21.2</b>	21.2	21.2	<b>8.1</b>	8.1	8.1	<b>2.61</b>	14.3	14.3	14.3
-6	<b>20.9</b>	20.9	20.9	<b>8.1</b>	8.1	8.1	<b>2.57</b>	14.3	14.3	14.3
-7	<b>20.6</b>	20.6	20.6	<b>8.1</b>	8.1	8.1	<b>2.53</b>	14.3	14.3	14.3
-8	<b>20.3</b>	20.3	20.3	<b>8.1</b>	8.1	8.1	<b>2.50</b>	14.3	14.3	14.3
-9	<b>20.1</b>	20.1	20.1	<b>8.1</b>	8.1	8.1	<b>2.48</b>	14.3	14.3	14.3
-10	<b>20.0</b>	20.0	20.0	<b>8.1</b>	8.1	8.1	<b>2.46</b>	14.3	14.3	14.3
-11	<b>19.4</b>	19.4	19.4	<b>8.1</b>	8.1	8.1	<b>2.39</b>	14.3	14.3	14.3
-12	<b>18.9</b>	18.9	18.9	<b>8.1</b>	8.1	8.1	<b>2.33</b>	14.3	14.3	14.3
-13	<b>18.4</b>	18.4	18.4	<b>8.1</b>	8.1	8.1	<b>2.27</b>	14.2	14.2	14.2
-14	<b>17.9</b>	17.9	17.9	<b>8.1</b>	8.1	8.1	<b>2.21</b>	14.2	14.2	14.2
-15	<b>17.4</b>	17.4	17.4	<b>8.1</b>	8.1	8.1	<b>2.15</b>	14.2	14.2	14.2
-16	<b>17.0</b>	17.0	17.0	<b>8.1</b>	8.1	8.1	<b>2.10</b>	14.2	14.2	14.2
-17	<b>16.5</b>	16.5	16.5	<b>8.1</b>	8.1	8.1	<b>2.04</b>	14.2	14.2	14.2
-18	<b>16.1</b>	16.1	16.1	<b>8.1</b>	8.1	8.1	<b>1.99</b>	14.1	14.1	14.1
-19	<b>15.6</b>	15.6	15.6	<b>8.1</b>	8.1	8.1	<b>1.93</b>	14.1	14.1	14.1
-20	<b>15.2</b>	15.2	15.2	<b>8.1</b>	8.1	8.1	<b>1.88</b>	14.1	14.1	14.1
-21	<b>14.8</b>	14.8	14.8	<b>8.1</b>	8.1	8.1	<b>1.83</b>	14.1	14.1	14.1
-22	<b>14.4</b>	14.4	14.4	<b>8.1</b>	8.1	8.1	<b>1.78</b>	14.0	14.0	14.0
-23	<b>14.0</b>	14.0	14.0	<b>8.1</b>	8.1	8.1	<b>1.73</b>	14.0	14.0	14.0
-24	<b>13.6</b>	13.6	13.6	<b>8.1</b>	8.1	8.1	<b>1.68</b>	14.0	14.0	14.0
-25	<b>13.2</b>	13.2	13.2	<b>8.1</b>	8.1	8.1	<b>1.63</b>	13.9	13.9	13.9

\* Achtung: Betriebsgrenzen beachten - nicht in Tabelle festgehalten

Th [°C]		55 °C								
Ta [°C]	Qh nom [kW]	Qh min [kW]	Qh max [kW]	Pin nom [kW]	Pin-min [kW]	Pin-max [kW]	COP kW / kW	I nom [A]	I min [A]	I max [A]
25	<b>43.6</b>	43.6	43.6	<b>10.0</b>	10.0	10.0	<b>4.36</b>	16.3	16.3	16.3
24	<b>42.8</b>	42.8	42.8	<b>10.0</b>	10.0	10.0	<b>4.26</b>	16.4	16.4	16.4
23	<b>42.0</b>	42.0	42.0	<b>10.1</b>	10.1	10.1	<b>4.16</b>	16.4	16.4	16.4
22	<b>41.2</b>	41.2	41.2	<b>10.1</b>	10.1	10.1	<b>4.07</b>	16.5	16.5	16.5
21	<b>40.4</b>	40.4	40.4	<b>10.2</b>	10.2	10.2	<b>3.98</b>	16.5	16.5	16.5
20	<b>39.7</b>	39.7	39.7	<b>10.2</b>	10.2	10.2	<b>3.89</b>	16.6	16.6	16.6
19	<b>38.9</b>	38.9	38.9	<b>10.2</b>	10.2	10.2	<b>3.81</b>	16.6	16.6	16.6
18	<b>38.2</b>	38.2	38.2	<b>10.3</b>	10.3	10.3	<b>3.72</b>	16.7	16.7	16.7
17	<b>37.4</b>	37.4	37.4	<b>10.3</b>	10.3	10.3	<b>3.64</b>	16.7	16.7	16.7
16	<b>36.7</b>	36.7	36.7	<b>10.3</b>	10.3	10.3	<b>3.56</b>	16.8	16.8	16.8
15	<b>36.0</b>	36.0	36.0	<b>10.3</b>	10.3	10.3	<b>3.48</b>	16.8	16.8	16.8
14	<b>35.3</b>	35.3	35.3	<b>10.3</b>	10.3	10.3	<b>3.41</b>	16.8	16.8	16.8
13	<b>34.6</b>	34.6	34.6	<b>10.4</b>	10.4	10.4	<b>3.33</b>	16.9	16.9	16.9
12	<b>33.9</b>	33.9	33.9	<b>10.4</b>	10.4	10.4	<b>3.26</b>	16.9	16.9	16.9
11	<b>33.2</b>	33.2	33.2	<b>10.4</b>	10.4	10.4	<b>3.19</b>	16.9	16.9	16.9
10	<b>32.5</b>	32.5	32.5	<b>10.4</b>	10.4	10.4	<b>3.12</b>	16.9	16.9	16.9
9	<b>31.4</b>	31.4	31.4	<b>10.4</b>	10.4	10.4	<b>3.01</b>	17.0	17.0	17.0
8	<b>30.3</b>	30.3	30.3	<b>10.4</b>	10.4	10.4	<b>2.90</b>	17.0	17.0	17.0
7	<b>29.3</b>	29.3	29.3	<b>10.5</b>	10.5	10.5	<b>2.80</b>	17.0	17.0	17.0
6	<b>28.4</b>	28.4	28.4	<b>10.5</b>	10.5	10.5	<b>2.71</b>	17.0	17.0	17.0
5	<b>27.5</b>	27.5	27.5	<b>10.5</b>	10.5	10.5	<b>2.63</b>	17.0	17.0	17.0
4	<b>26.7</b>	26.7	26.7	<b>10.5</b>	10.5	10.5	<b>2.55</b>	17.0	17.0	17.0
3	<b>25.9</b>	25.9	25.9	<b>10.5</b>	10.5	10.5	<b>2.48</b>	17.0	17.0	17.0
2	<b>25.2</b>	25.2	25.2	<b>10.5</b>	10.5	10.5	<b>2.41</b>	17.0	17.0	17.0
1	<b>24.6</b>	24.6	24.6	<b>10.5</b>	10.5	10.5	<b>2.35</b>	17.0	17.0	17.0
0	<b>24.0</b>	24.0	24.0	<b>10.5</b>	10.5	10.5	<b>2.29</b>	17.0	17.0	17.0
-1	<b>23.5</b>	23.5	23.5	<b>10.5</b>	10.5	10.5	<b>2.24</b>	17.0	17.0	17.0
-2	<b>23.0</b>	23.0	23.0	<b>10.5</b>	10.5	10.5	<b>2.20</b>	17.0	17.0	17.0
-3	<b>22.5</b>	22.5	22.5	<b>10.5</b>	10.5	10.5	<b>2.15</b>	17.0	17.0	17.0
-4	<b>22.1</b>	22.1	22.1	<b>10.5</b>	10.5	10.5	<b>2.12</b>	17.0	17.0	17.0
-5	<b>21.8</b>	21.8	21.8	<b>10.5</b>	10.5	10.5	<b>2.08</b>	17.0	17.0	17.0
-6	<b>21.5</b>	21.5	21.5	<b>10.5</b>	10.5	10.5	<b>2.05</b>	17.0	17.0	17.0
-7	<b>21.2</b>	21.2	21.2	<b>10.5</b>	10.5	10.5	<b>2.02</b>	17.0	17.0	17.0
-8	<b>21.0</b>	21.0	21.0	<b>10.5</b>	10.5	10.5	<b>2.00</b>	16.9	16.9	16.9
-9	<b>20.8</b>	20.8	20.8	<b>10.5</b>	10.5	10.5	<b>1.98</b>	16.9	16.9	16.9
-10	<b>20.6</b>	20.6	20.6	<b>10.5</b>	10.5	10.5	<b>1.97</b>	16.9	16.9	16.9
-11	<b>20.1</b>	20.1	20.1	<b>10.5</b>	10.5	10.5	<b>1.92</b>	16.9	16.9	16.9
-12	<b>19.6</b>	19.6	19.6	<b>10.5</b>	10.5	10.5	<b>1.87</b>	16.9	16.9	16.9
-13	<b>19.2</b>	19.2	19.2	<b>10.5</b>	10.5	10.5	<b>1.83</b>	16.9	16.9	16.9
-14	<b>18.7</b>	18.7	18.7	<b>10.5</b>	10.5	10.5	<b>1.78</b>	16.8	16.8	16.8
-15	<b>18.3</b>	18.3	18.3	<b>10.5</b>	10.5	10.5	<b>1.74</b>	16.8	16.8	16.8
-16	<b>17.8</b>	17.8	17.8	<b>10.5</b>	10.5	10.5	<b>1.70</b>	16.8	16.8	16.8
-17	<b>17.4</b>	17.4	17.4	<b>10.5</b>	10.5	10.5	<b>1.66</b>	16.7	16.7	16.7
-18	<b>17.0</b>	17.0	17.0	<b>10.5</b>	10.5	10.5	<b>1.62</b>	16.7	16.7	16.7
-19	<b>16.6</b>	16.6	16.6	<b>10.5</b>	10.5	10.5	<b>1.57</b>	16.6	16.6	16.6
-20	<b>16.2</b>	16.2	16.2	<b>10.5</b>	10.5	10.5	<b>1.54</b>	16.6	16.6	16.6
-21	<b>15.8</b>	15.8	15.8	<b>10.5</b>	10.5	10.5	<b>1.50</b>	16.5	16.5	16.5
-22	<b>15.4</b>	15.4	15.4	<b>10.5</b>	10.5	10.5	<b>1.46</b>	16.5	16.5	16.5
-23	<b>15.0</b>	15.0	15.0	<b>10.6</b>	10.6	10.6	<b>1.42</b>	16.5	16.5	16.5
-24	<b>14.7</b>	14.7	14.7	<b>10.6</b>	10.6	10.6	<b>1.39</b>	16.4	16.4	16.4
-25	<b>14.3</b>	14.3	14.3	<b>10.6</b>	10.6	10.6	<b>1.35</b>	16.3	16.3	16.3

\* Achtung: Betriebsgrenzen beachten - nicht in Tabelle festgehalten

Th [°C]		T-Max @ 65 °C								
Ta [°C]	Qh nom [kW]	Qh min [kW]	Qh max [kW]	Pin nom [kW]	Pin-min [kW]	Pin-max [kW]	COP kW / kW	I nom [A]	I min [A]	I max [A]
25	<b>43.3</b>	43.3	43.3	<b>13.2</b>	13.2	13.2	<b>3.28</b>	20.2	20.2	20.2
24	<b>42.6</b>	42.6	42.6	<b>13.3</b>	13.3	13.3	<b>3.21</b>	20.3	20.3	20.3
23	<b>41.8</b>	41.8	41.8	<b>13.3</b>	13.3	13.3	<b>3.15</b>	20.4	20.4	20.4
22	<b>41.1</b>	41.1	41.1	<b>13.3</b>	13.3	13.3	<b>3.08</b>	20.4	20.4	20.4
21	<b>40.4</b>	40.4	40.4	<b>13.4</b>	13.4	13.4	<b>3.02</b>	20.4	20.4	20.4
20	<b>39.6</b>	39.6	39.6	<b>13.4</b>	13.4	13.4	<b>2.96</b>	20.5	20.5	20.5
19	<b>38.9</b>	38.9	38.9	<b>13.4</b>	13.4	13.4	<b>2.90</b>	20.5	20.5	20.5
18	<b>38.2</b>	38.2	38.2	<b>13.4</b>	13.4	13.4	<b>2.85</b>	20.6	20.6	20.6
17	<b>37.5</b>	37.5	37.5	<b>13.4</b>	13.4	13.4	<b>2.79</b>	20.6	20.6	20.6
16	<b>36.8</b>	36.8	36.8	<b>13.5</b>	13.5	13.5	<b>2.74</b>	20.6	20.6	20.6
15	<b>36.2</b>	36.2	36.2	<b>13.5</b>	13.5	13.5	<b>2.68</b>	20.7	20.7	20.7
14	<b>35.5</b>	35.5	35.5	<b>13.5</b>	13.5	13.5	<b>2.63</b>	20.7	20.7	20.7
13	<b>34.8</b>	34.8	34.8	<b>13.5</b>	13.5	13.5	<b>2.58</b>	20.7	20.7	20.7
12	<b>34.2</b>	34.2	34.2	<b>13.5</b>	13.5	13.5	<b>2.53</b>	20.7	20.7	20.7
11	<b>33.5</b>	33.5	33.5	<b>13.5</b>	13.5	13.5	<b>2.48</b>	20.8	20.8	20.8
10	<b>32.9</b>	32.9	32.9	<b>13.5</b>	13.5	13.5	<b>2.43</b>	20.8	20.8	20.8
9	<b>31.9</b>	31.9	31.9	<b>13.6</b>	13.6	13.6	<b>2.35</b>	20.8	20.8	20.8
8	<b>30.9</b>	30.9	30.9	<b>13.6</b>	13.6	13.6	<b>2.27</b>	20.8	20.8	20.8
7	<b>29.9</b>	29.9	29.9	<b>13.6</b>	13.6	13.6	<b>2.20</b>	20.8	20.8	20.8
6	<b>29.1</b>	29.1	29.1	<b>13.6</b>	13.6	13.6	<b>2.14</b>	20.8	20.8	20.8
5	<b>28.2</b>	28.2	28.2	<b>13.6</b>	13.6	13.6	<b>2.08</b>	20.8	20.8	20.8
4	<b>27.5</b>	27.5	27.5	<b>13.6</b>	13.6	13.6	<b>2.02</b>	20.8	20.8	20.8
3	<b>26.8</b>	26.8	26.8	<b>13.6</b>	13.6	13.6	<b>1.97</b>	20.8	20.8	20.8
2	<b>26.2</b>	26.2	26.2	<b>13.6</b>	13.6	13.6	<b>1.92</b>	20.8	20.8	20.8
1	<b>25.6</b>	25.6	25.6	<b>13.6</b>	13.6	13.6	<b>1.87</b>	20.8	20.8	20.8
0	<b>25.0</b>	25.0	25.0	<b>13.6</b>	13.6	13.6	<b>1.83</b>	20.7	20.7	20.7
-1	<b>24.5</b>	24.5	24.5	<b>13.7</b>	13.7	13.7	<b>1.80</b>	20.7	20.7	20.7
-2	<b>24.1</b>	24.1	24.1	<b>13.7</b>	13.7	13.7	<b>1.76</b>	20.7	20.7	20.7
-3	<b>23.7</b>	23.7	23.7	<b>13.7</b>	13.7	13.7	<b>1.73</b>	20.7	20.7	20.7
-4	<b>23.3</b>	23.3	23.3	<b>13.7</b>	13.7	13.7	<b>1.70</b>	20.7	20.7	20.7
-5	<b>23.0</b>	23.0	23.0	<b>13.7</b>	13.7	13.7	<b>1.68</b>	20.6	20.6	20.6
-6	<b>22.7</b>	22.7	22.7	<b>13.7</b>	13.7	13.7	<b>1.66</b>	20.6	20.6	20.6
-7	<b>22.4</b>	22.4	22.4	<b>13.7</b>	13.7	13.7	<b>1.64</b>	20.6	20.6	20.6
-8	<b>22.2</b>	22.2	22.2	<b>13.7</b>	13.7	13.7	<b>1.62</b>	20.6	20.6	20.6
-9	<b>22.0</b>	22.0	22.0	<b>13.7</b>	13.7	13.7	<b>1.61</b>	20.6	20.6	20.6
-10	<b>21.9</b>	21.9	21.9	<b>13.7</b>	13.7	13.7	<b>1.60</b>	20.6	20.6	20.6
-11	<b>21.5</b>	21.5	21.5	<b>13.7</b>	13.7	13.7	<b>1.56</b>	20.5	20.5	20.5
-12	<b>21.0</b>	21.0	21.0	<b>13.7</b>	13.7	13.7	<b>1.53</b>	20.5	20.5	20.5
-13	<b>20.6</b>	20.6	20.6	<b>13.7</b>	13.7	13.7	<b>1.50</b>	20.4	20.4	20.4
-14	<b>20.2</b>	20.2	20.2	<b>13.8</b>	13.8	13.8	<b>1.47</b>	20.4	20.4	20.4
-15	<b>19.8</b>	19.8	19.8	<b>13.8</b>	13.8	13.8	<b>1.43</b>	20.4	20.4	20.4
-16										
-17										
-18										
-19										
-20										
-21										
-22										
-23										
-24										
-25										

\* Achtung: Betriebsgrenzen beachten - nicht in Tabelle festgehalten

Tc [°C]		W 12 / 7 °C								
Ta [°C]	Qc nom [kW]	Qc min [kW]	Qc max [kW]	Pin [kW]	Pin min [kW]	Pin max [kW]	EER kW / kW	I nom [A]	I min [A]	I max [A]
40	<b>20.1</b>	20.1	20.1	<b>8.8</b>	8.8	8.8	<b>2.29</b>	15.0	15.0	15.0
39	<b>20.3</b>	20.3	20.3	<b>8.5</b>	8.5	8.5	<b>2.37</b>	14.7	14.7	14.7
38	<b>20.4</b>	20.4	20.4	<b>8.3</b>	8.3	8.3	<b>2.45</b>	14.5	14.5	14.5
37	<b>20.6</b>	20.6	20.6	<b>8.1</b>	8.1	8.1	<b>2.53</b>	14.3	14.3	14.3
36	<b>20.8</b>	20.8	20.8	<b>7.9</b>	7.9	7.9	<b>2.62</b>	14.0	14.0	14.0
35	<b>20.9</b>	20.9	20.9	<b>7.7</b>	7.7	7.7	<b>2.70</b>	13.8	13.8	13.8
34	<b>21.1</b>	21.1	21.1	<b>7.6</b>	7.6	7.6	<b>2.79</b>	13.6	13.6	13.6
33	<b>21.2</b>	21.2	21.2	<b>7.4</b>	7.4	7.4	<b>2.88</b>	13.4	13.4	13.4
32	<b>21.4</b>	21.4	21.4	<b>7.2</b>	7.2	7.2	<b>2.97</b>	13.2	13.2	13.2
31	<b>21.5</b>	21.5	21.5	<b>7.0</b>	7.0	7.0	<b>3.06</b>	13.0	13.0	13.0
30	<b>21.7</b>	21.7	21.7	<b>6.9</b>	6.9	6.9	<b>3.16</b>	12.8	12.8	12.8
29	<b>21.8</b>	21.8	21.8	<b>6.7</b>	6.7	6.7	<b>3.26</b>	12.7	12.7	12.7
28	<b>21.9</b>	21.9	21.9	<b>6.5</b>	6.5	6.5	<b>3.35</b>	12.5	12.5	12.5
27	<b>22.1</b>	22.1	22.1	<b>6.4</b>	6.4	6.4	<b>3.46</b>	12.4	12.4	12.4
26	<b>22.2</b>	22.2	22.2	<b>6.2</b>	6.2	6.2	<b>3.56</b>	12.2	12.2	12.2
25	<b>22.3</b>	22.3	22.3	<b>6.1</b>	6.1	6.1	<b>3.67</b>	12.1	12.1	12.1
24	<b>22.4</b>	22.4	22.4	<b>5.9</b>	5.9	5.9	<b>3.77</b>	11.9	11.9	11.9
23	<b>22.6</b>	22.6	22.6	<b>5.8</b>	5.8	5.8	<b>3.89</b>	11.8	11.8	11.8
22	<b>22.7</b>	22.7	22.7	<b>5.7</b>	5.7	5.7	<b>4.00</b>	11.7	11.7	11.7
21	<b>22.8</b>	22.8	22.8	<b>5.5</b>	5.5	5.5	<b>4.12</b>	11.5	11.5	11.5
20	<b>22.9</b>	22.9	22.9	<b>5.4</b>	5.4	5.4	<b>4.24</b>	11.4	11.4	11.4
19	<b>23.0</b>	23.0	23.0	<b>5.3</b>	5.3	5.3	<b>4.36</b>	11.3	11.3	11.3
18	<b>23.1</b>	23.1	23.1	<b>5.1</b>	5.1	5.1	<b>4.49</b>	11.2	11.2	11.2
17	<b>23.2</b>	23.2	23.2	<b>5.0</b>	5.0	5.0	<b>4.62</b>	11.1	11.1	11.1

Tc [°C]		W 23 / 18 °C								
Ta [°C]	Qc [kW]	Qh-min [kW]	Qh-max [kW]	Pin [kW]	Pin-min [kW]	Pin-max [kW]	EER kW / kW	I [A]	I-min [A]	I-max [A]
40	<b>27.4</b>	27.4	27.4	<b>8.8</b>	8.8	8.8	<b>3.13</b>	14.8	14.8	14.8
39	<b>27.6</b>	27.6	27.6	<b>8.5</b>	8.5	8.5	<b>3.23</b>	14.5	14.5	14.5
38	<b>27.8</b>	27.8	27.8	<b>8.3</b>	8.3	8.3	<b>3.34</b>	14.2	14.2	14.2
37	<b>28.0</b>	28.0	28.0	<b>8.1</b>	8.1	8.1	<b>3.44</b>	14.0	14.0	14.0
36	<b>28.2</b>	28.2	28.2	<b>7.9</b>	7.9	7.9	<b>3.55</b>	13.8	13.8	13.8
35	<b>28.4</b>	28.4	28.4	<b>7.7</b>	7.7	7.7	<b>3.67</b>	13.6	13.6	13.6
34	<b>28.6</b>	28.6	28.6	<b>7.6</b>	7.6	7.6	<b>3.78</b>	13.3	13.3	13.3
33	<b>28.7</b>	28.7	28.7	<b>7.4</b>	7.4	7.4	<b>3.90</b>	13.1	13.1	13.1
32	<b>28.9</b>	28.9	28.9	<b>7.2</b>	7.2	7.2	<b>4.02</b>	12.9	12.9	12.9
31	<b>29.1</b>	29.1	29.1	<b>7.0</b>	7.0	7.0	<b>4.14</b>	12.7	12.7	12.7
30	<b>29.3</b>	29.3	29.3	<b>6.9</b>	6.9	6.9	<b>4.26</b>	12.6	12.6	12.6
29	<b>29.4</b>	29.4	29.4	<b>6.7</b>	6.7	6.7	<b>4.39</b>	12.4	12.4	12.4
28	<b>29.6</b>	29.6	29.6	<b>6.5</b>	6.5	6.5	<b>4.52</b>	12.2	12.2	12.2
27	<b>29.7</b>	29.7	29.7	<b>6.4</b>	6.4	6.4	<b>4.65</b>	12.1	12.1	12.1
26	<b>29.9</b>	29.9	29.9	<b>6.2</b>	6.2	6.2	<b>4.79</b>	11.9	11.9	11.9
25	<b>30.0</b>	30.0	30.0	<b>6.1</b>	6.1	6.1	<b>4.93</b>	11.7	11.7	11.7
24	<b>30.2</b>	30.2	30.2	<b>5.9</b>	5.9	5.9	<b>5.07</b>	11.6	11.6	11.6
23	<b>30.3</b>	30.3	30.3	<b>5.8</b>	5.8	5.8	<b>5.22</b>	11.5	11.5	11.5
22	<b>30.4</b>	30.4	30.4	<b>5.7</b>	5.7	5.7	<b>5.37</b>	11.3	11.3	11.3
21	<b>30.5</b>	30.5	30.5	<b>5.5</b>	5.5	5.5	<b>5.52</b>	11.2	11.2	11.2
20	<b>30.7</b>	30.7	30.7	<b>5.4</b>	5.4	5.4	<b>5.68</b>	11.1	11.1	11.1
19	<b>30.8</b>	30.8	30.8	<b>5.3</b>	5.3	5.3	<b>5.84</b>	11.0	11.0	11.0
18	<b>30.9</b>	30.9	30.9	<b>5.1</b>	5.1	5.1	<b>6.01</b>	10.9	10.9	10.9
17	<b>31.0</b>	31.0	31.0	<b>5.0</b>	5.0	5.0	<b>6.18</b>	10.8	10.8	10.8

\* Achtung: Betriebsgrenzen beachten - nicht in Tabelle festgehalten

### LEGENDE:

Twq-RL: Temperatur Wärmequelle - Eintritt [°C]  
Tws-VL: Temperatur Wärmesenke - Vorlauf [°C]  
Tk-VL: Temperatur Kältesenke - Vorlauf [°C]  
Qh nom: Heizleistung nominal  
Qh min: Heizleistung minimal  
Qh max: Heizleistung maximal  
Pin nom: Aufnahme bei nominaler Heizleistung  
Pin min: Aufnahme bei minimaler Heizleistung  
Pin max: Aufnahme bei maximaler Heizleistung  
COP nom: Arbeitszahl bei nominaler Heizleistung  
Qc nom: Kälteleistung/Energieentnahme bei nominaler Heizleistung  
Qc min: Kälteleistung/Energieentnahme bei minimaler Heizleistung  
Qc max: Kälteleistung/Energieentnahme bei maximaler Heizleistung  
I nom: Stromaufnahme bei nominaler Heizleistung  
EER: Arbeitszahl bei nominaler Kälteleistung

# Betriebsgrenzen



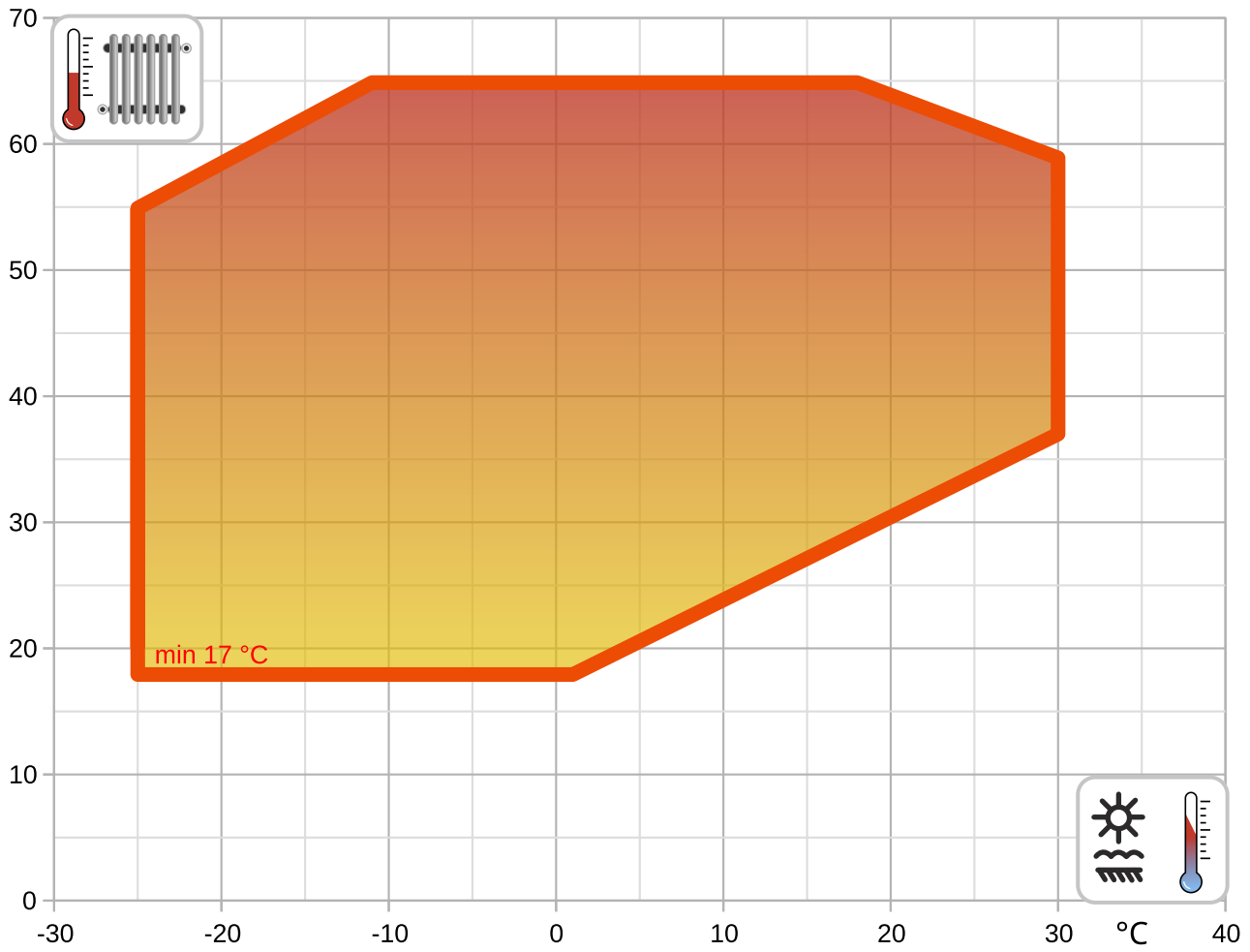

°C

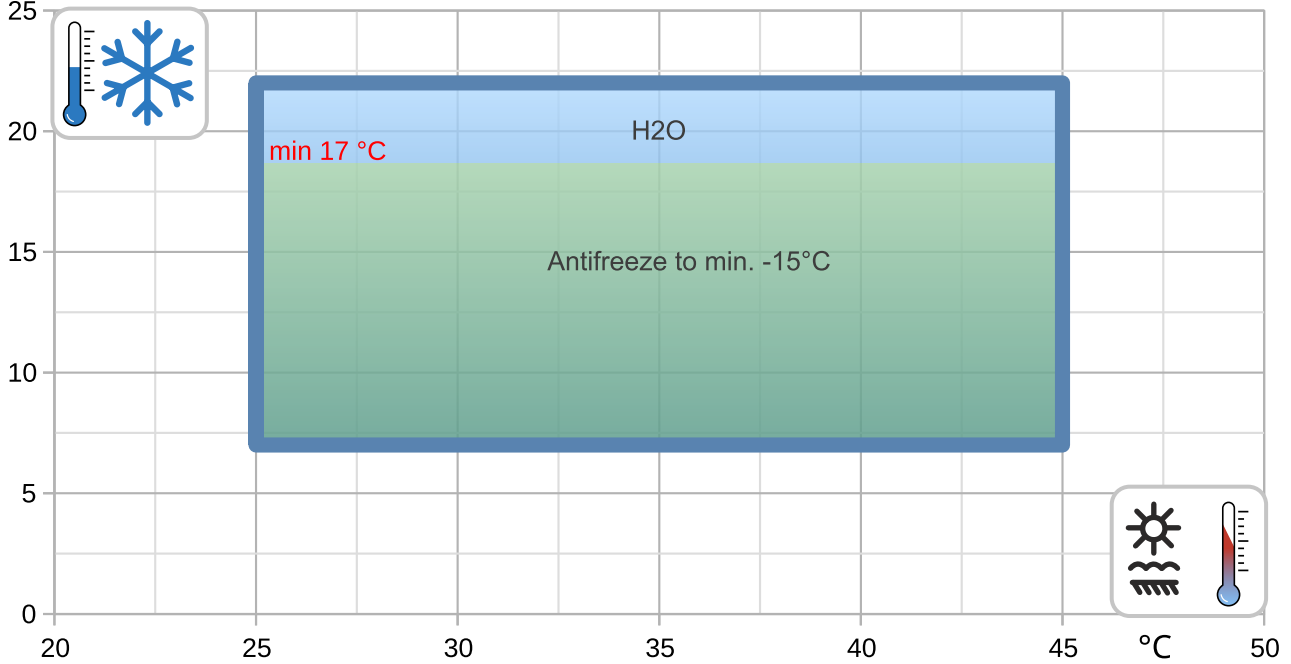

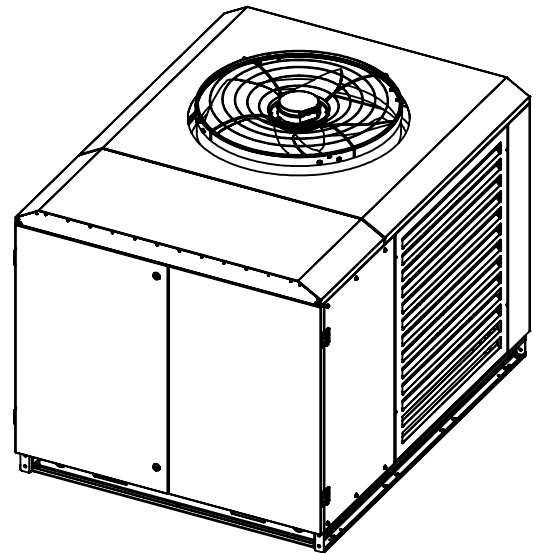
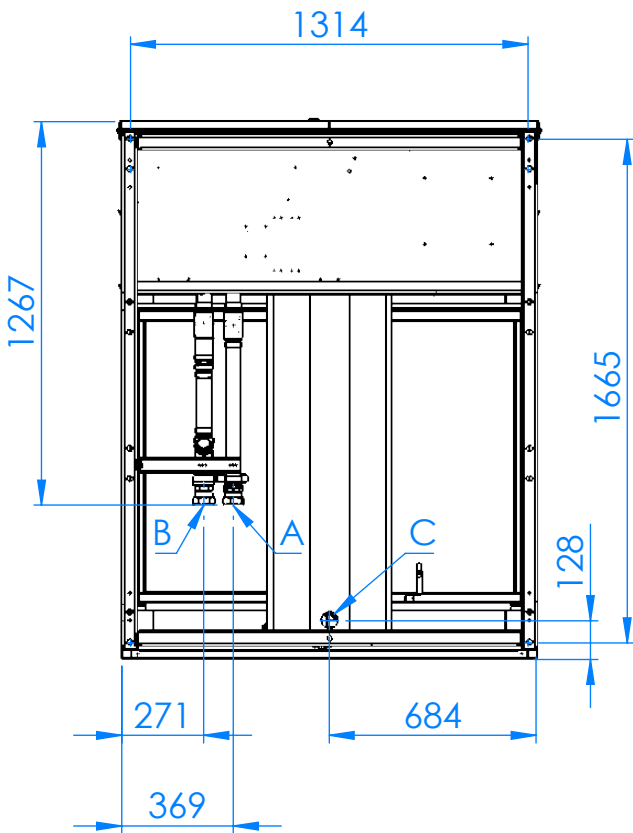
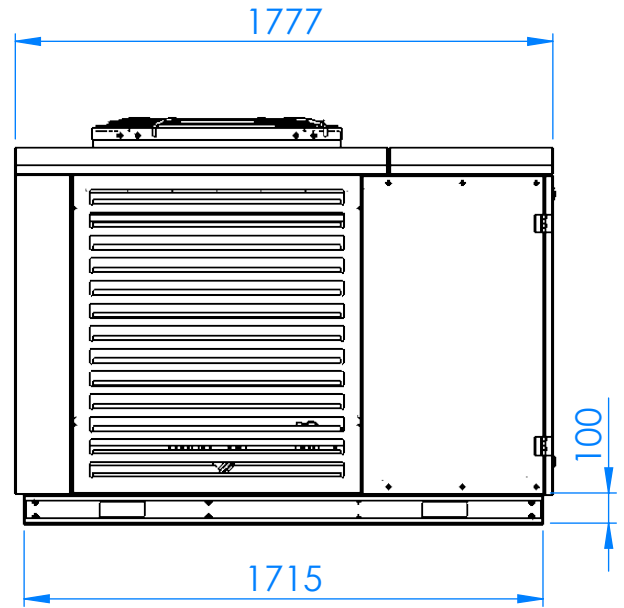
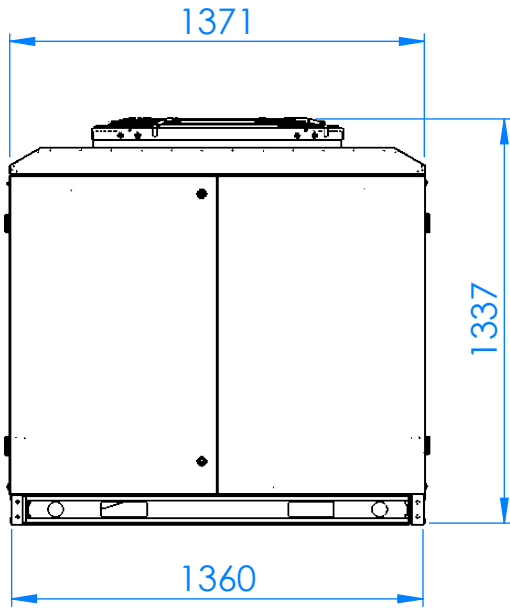
°C





- A -  → 
- B -  ← 
- C - Condens

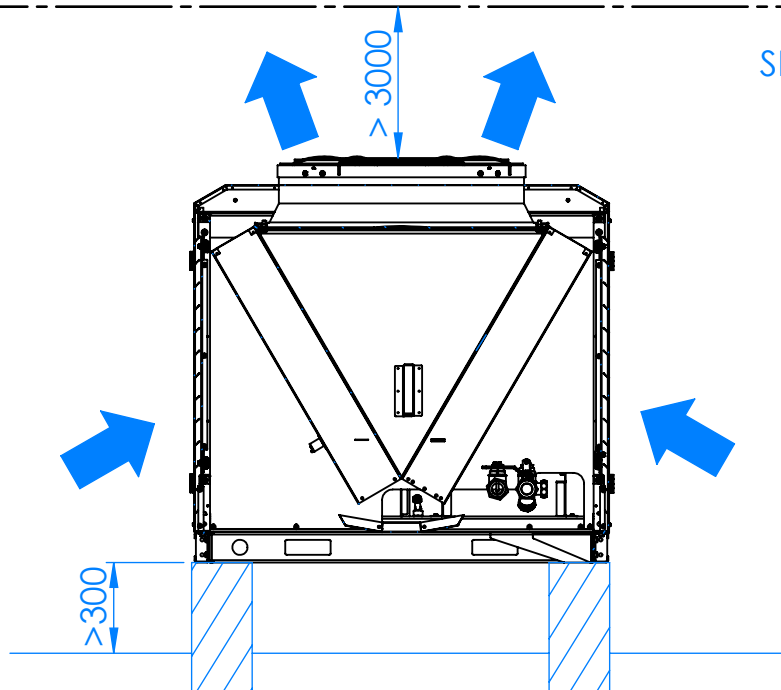
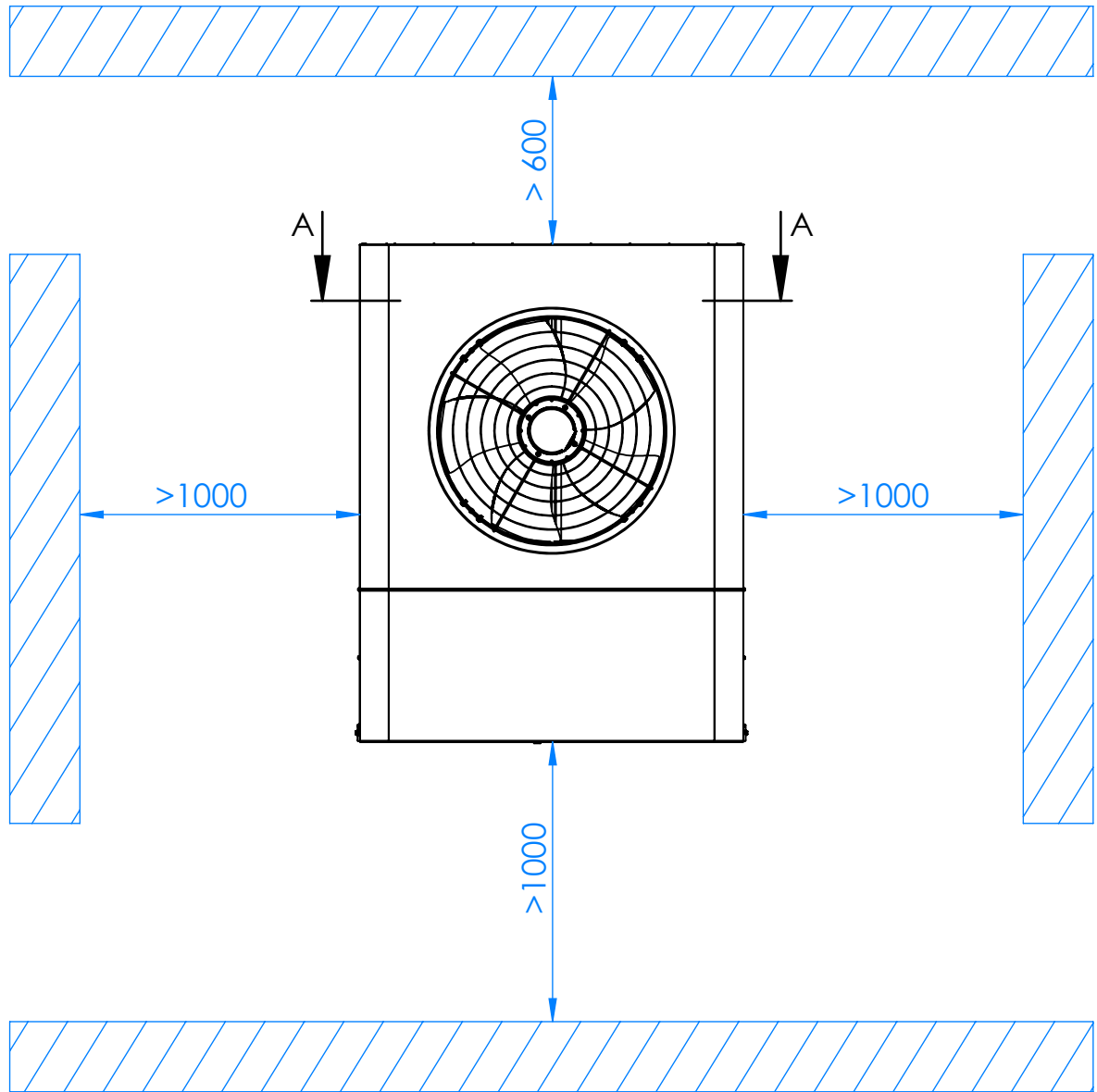



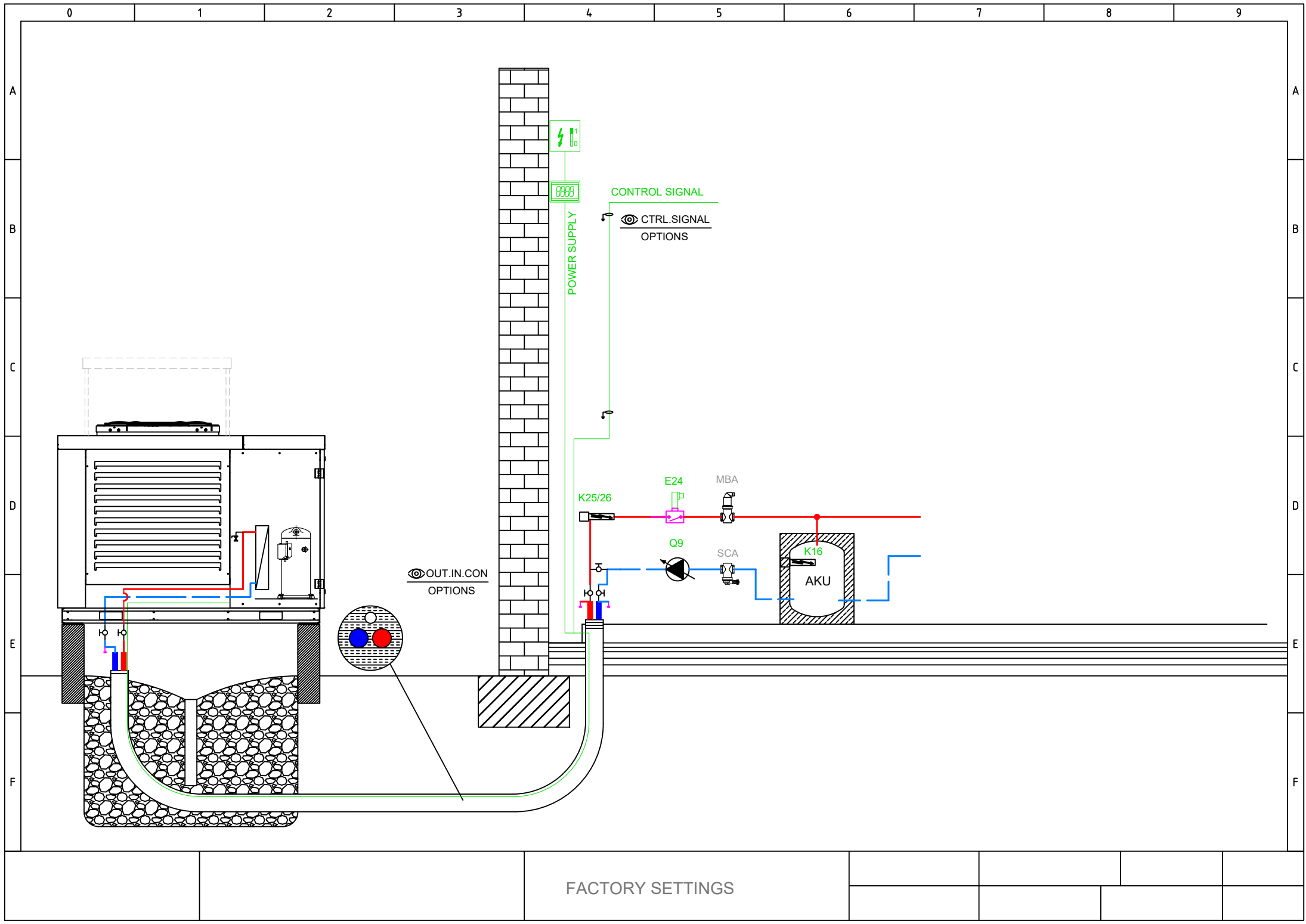

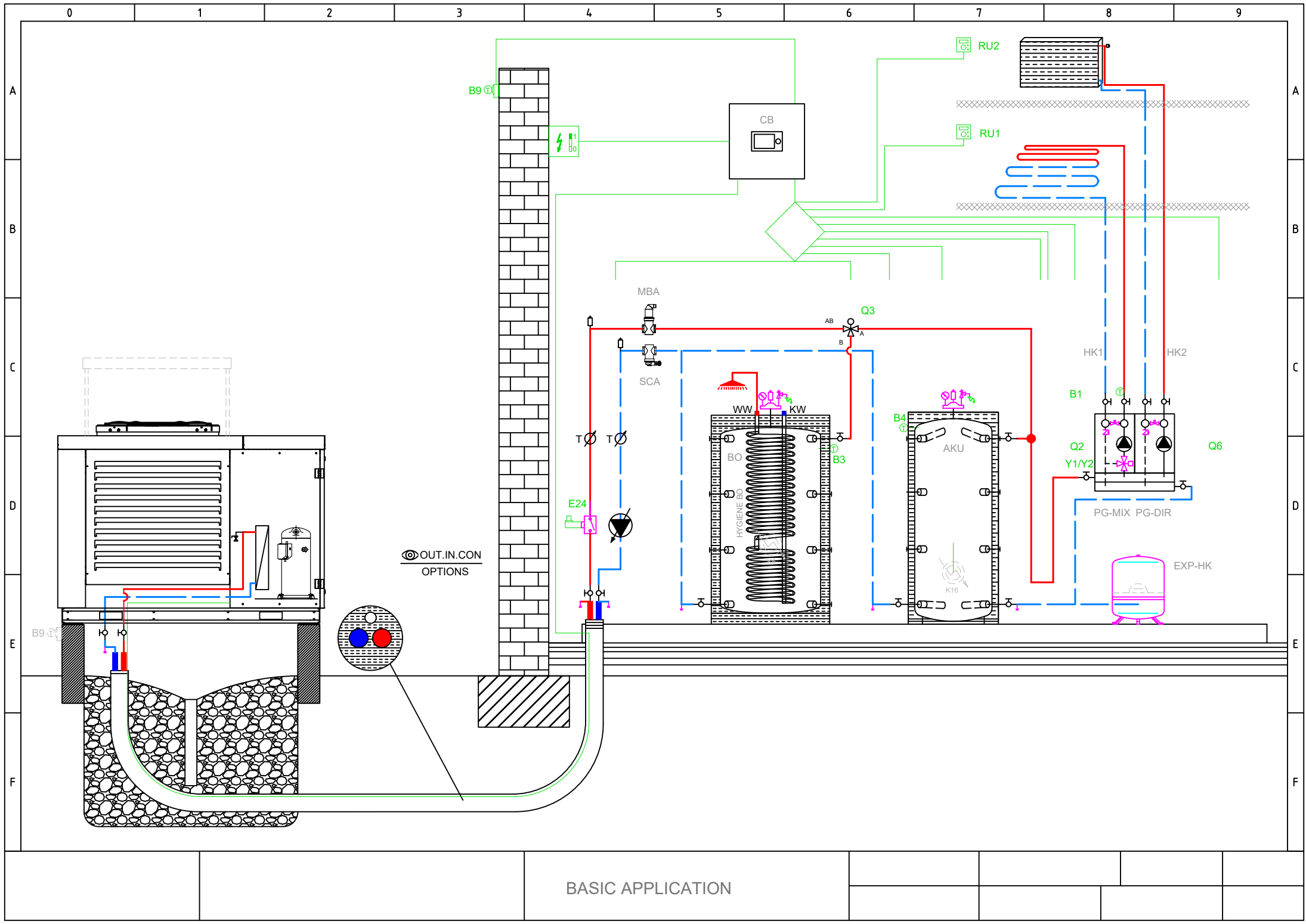

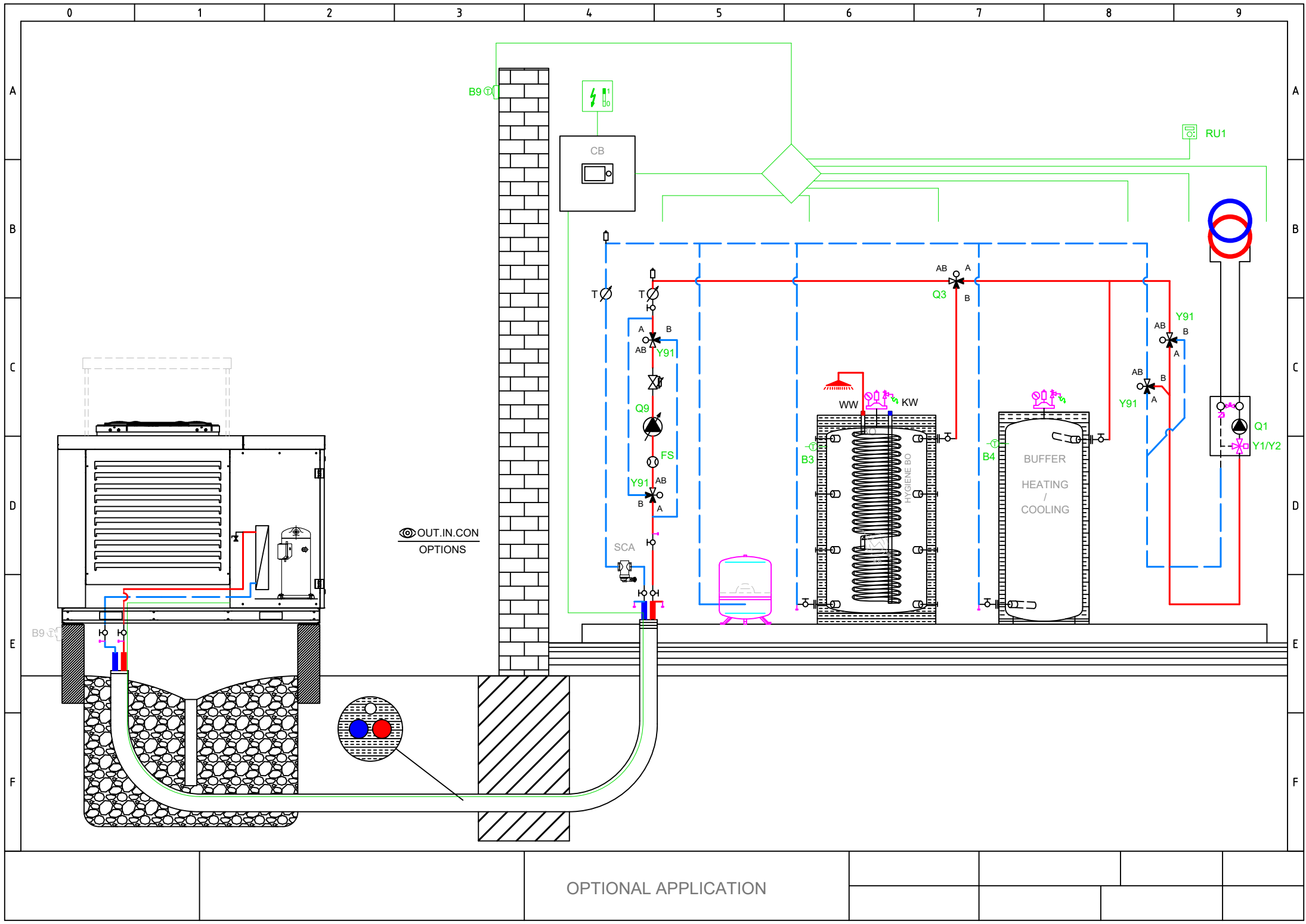



Netzanschluss 230V / 50 Hz

Erde  
Nullleiter

- E10 Hochdruckwächter E10
- E11 Überlast Verdichter 1 E11
- E14 Überlast Quelle E14
- E21 Netzüberwachung E21
- K82 Ventil EVI K82

K40 Ölsumpfheizung K40

- L Faze 230V
- K1 Verdichterstufe 1 K1
- Y22 Prozessumkehrventil Y22

Q9 Kondensatorpumpe Q9

X10	1	L
X10	1	PE
X10	1	N
X11	1	EX1
X11	1	EX2
X11	1	EX3
X11	1	EX4
X12	1	QX1
X12	1	N
X12	1	QX2
X12	1	QX2i
X12	1	N
X12	1	FX3
X15	1	QX3
X15	1	QX4
X15	1	QX4i
X15	1	N
X15	1	QX5
X15	1	N
X15	1	ZX6
X15	1	N
X86	1	GX1
X86	1	H3
X86	1	M
X86	1	H1
X86	1	G+
X86	1	M
X86	1	BSB

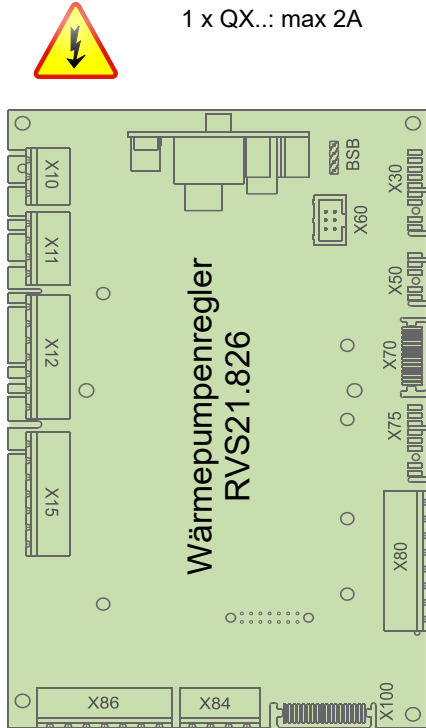

Total: max 6A  
1 x QX...: max 2A

BSB
X30
X60
X50
X70

- Anschluss Servicetool (OCI700)
- Bediengerät (HMI) AVS37.xxx
- Modbus-Clip-In OCI351.01
- Erweiterungsmodul AVS75.xxx
- LPB clip-in

D1
D2
D3
UX3
M
DI6
DI7
M

- D1 Digi Ausgang 1 Heizen
- D2 Digi Ausgang 2 Kühlung
- D3 Digi Ausgang 3 WP Ein/Aus
- DI6 Digi Eingang 6 Abtauen
- DI7 Digi Eingang 7 Alarm

BX1
M
BX2
M
UX1
M
UX2
M

- B91 Quelleneintrittfühler B91
- B84 Quellenaust'fühler B92/B84
- K19 Ventilator K19
- 0..10V Analogsignal
- Q9 Kondensatorpumpe Q9
- PWM Signal

BX3
M
BX4
M

- B71 WP Rücklauffühler B71
- B9 Aussentemperaturfühler B9

Netzanschluss 230V / 50 Hz

Erde  
Nullleiter

K10 Alarmausgang K10

V81 EEV Verdampfer V81

X10	1	L
X10	1	PE
X10	1	N
X110	1	QX31
X110	1	QX32
X110	1	QX33
X110	1	N
X110	1	QX33
X110	1	ZX34
X110	1	N
X110	1	QX35
X110	1	QX35i
X115	1	N

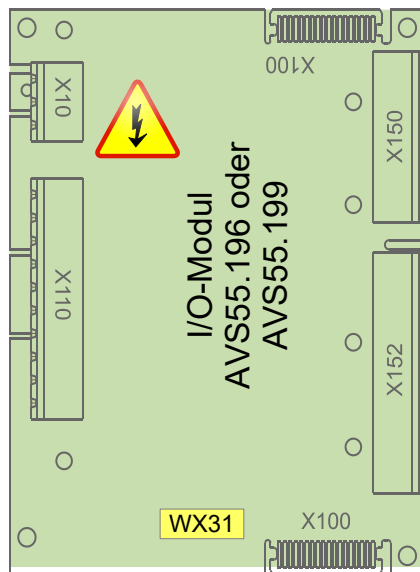

BSB
M
G+
H31
M
H32
GX1
H33
M
BX31
M
BX32
M
BX33
M
BX34
M

- 5V/12V für aktive Fühler
- Durchflussmessung 10V
- Niederdruck 0..10V
- 5V/12V für aktive Fühler
- Hochdruck 0..10V
- B21 WP Vorlauffühler B21
- B81 Heissgasfühler B81
- B85 Sauggasfühler B85
- B83 Kältemittelfühler flüssig B83

- AVS75.390
- AVS75.391
- AVS75.370

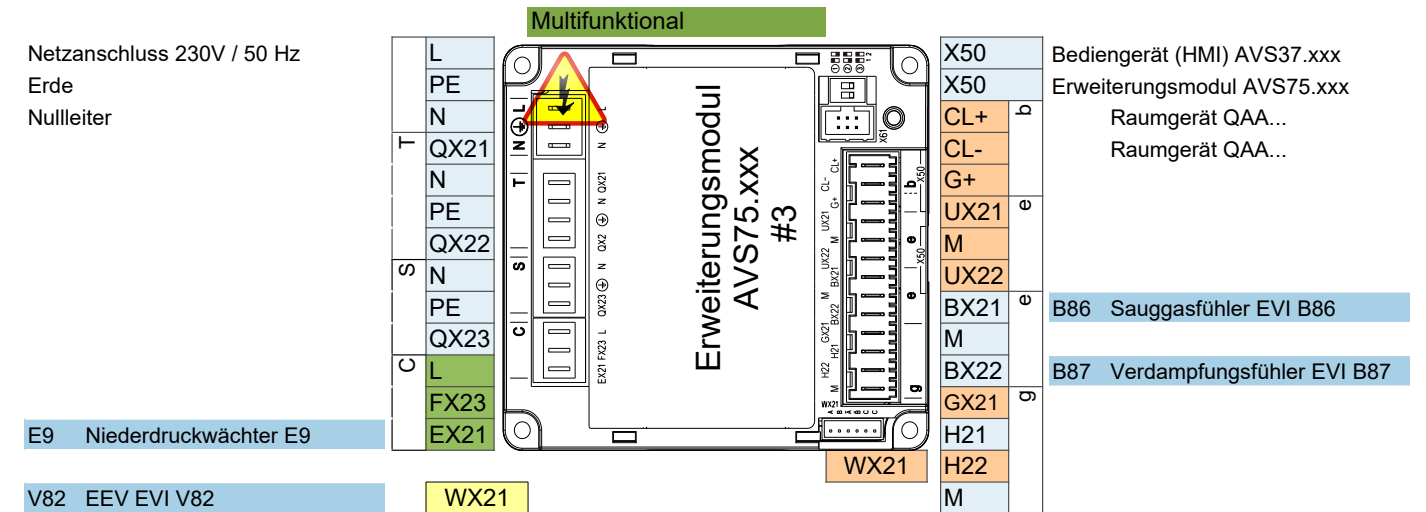
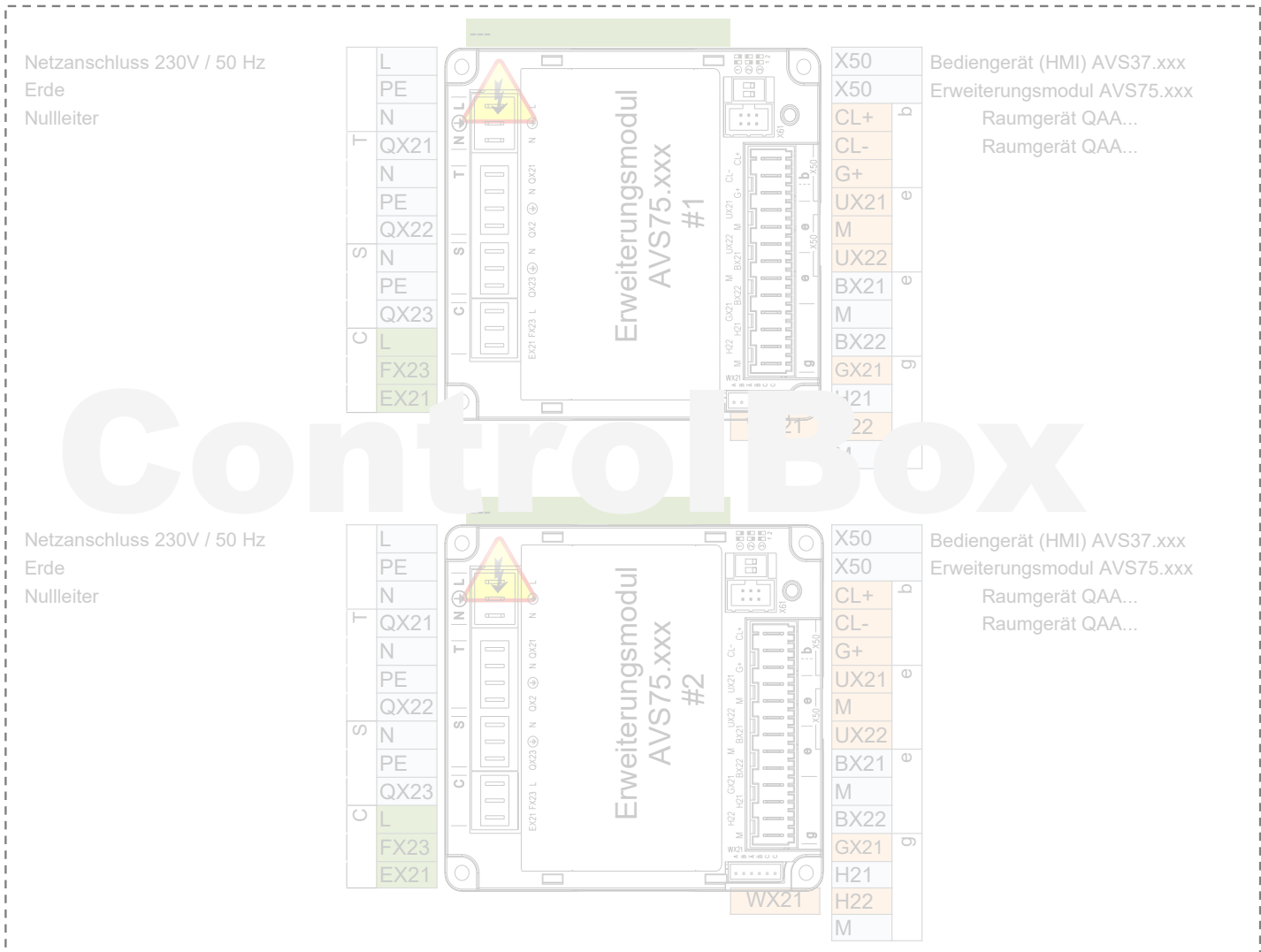

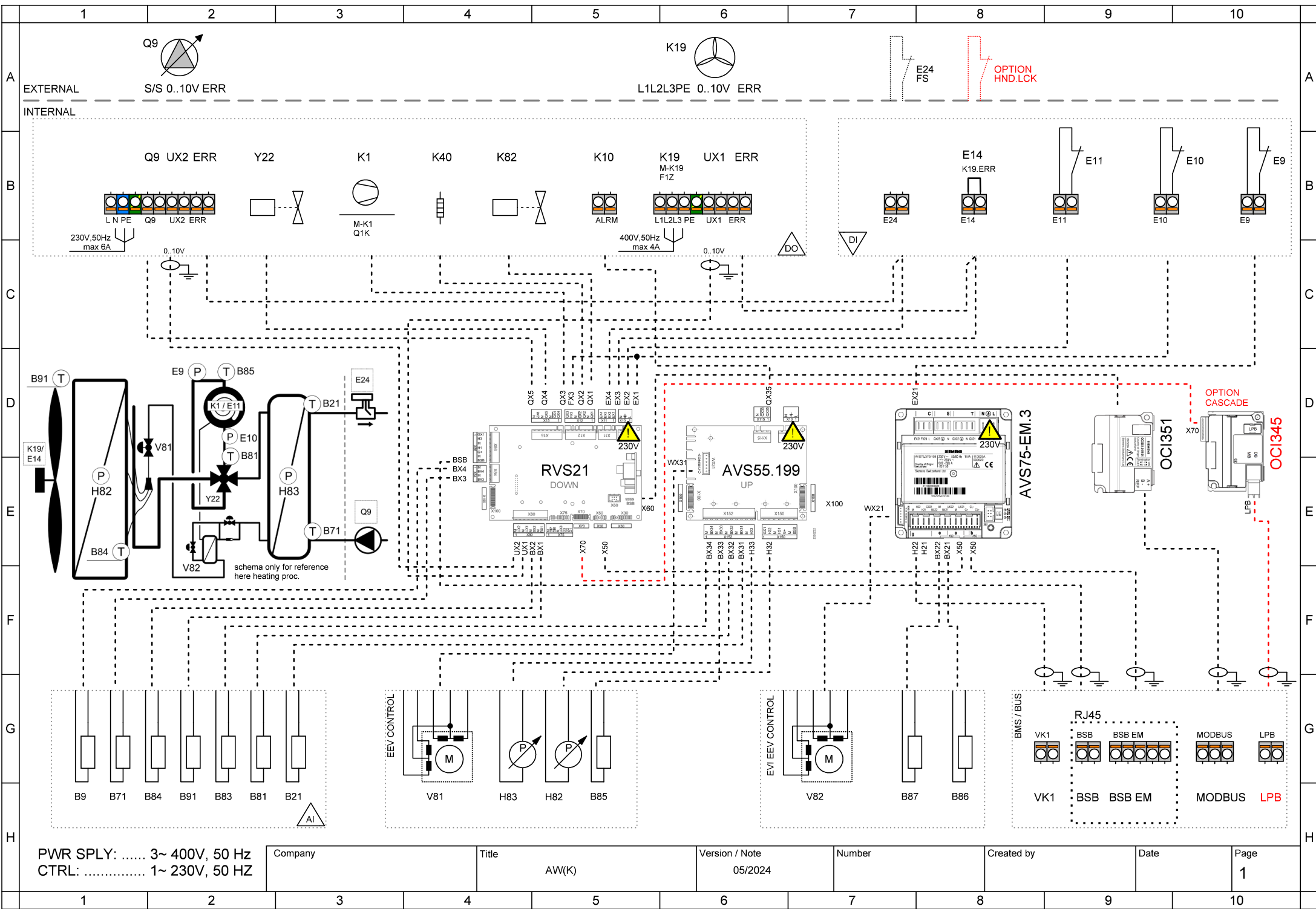

PWR SPLY: ..... 3~ 400V, 50 Hz  
 CTRL: ..... 1~ 230V, 50 HZ

Company	Title	Version / Note	Number	Created by	Date	Page
	AW(K)	05/2024				1

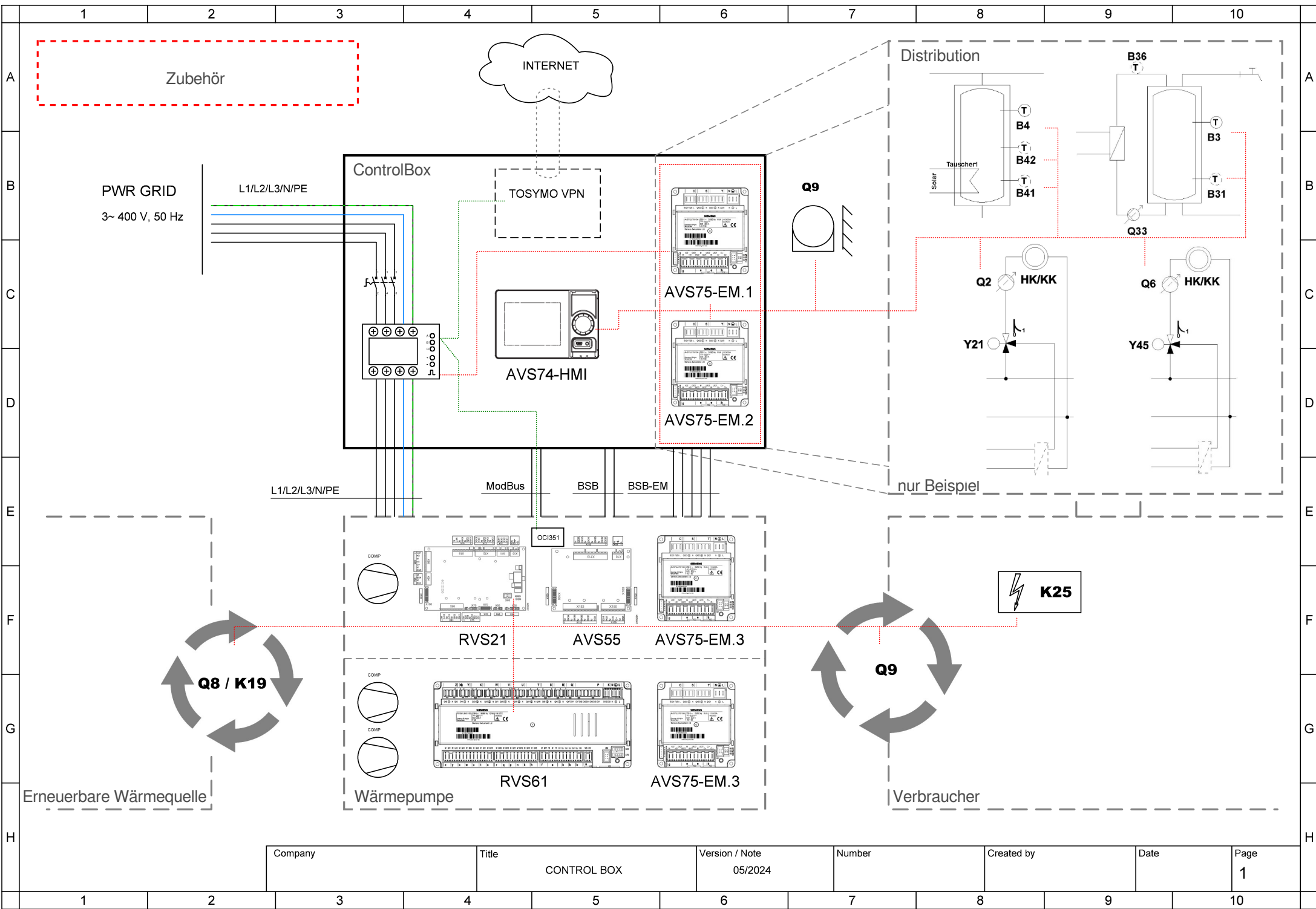

Company	Title	Version / Note	Number	Created by	Date	Page
	CONTROL BOX	05/2024				1

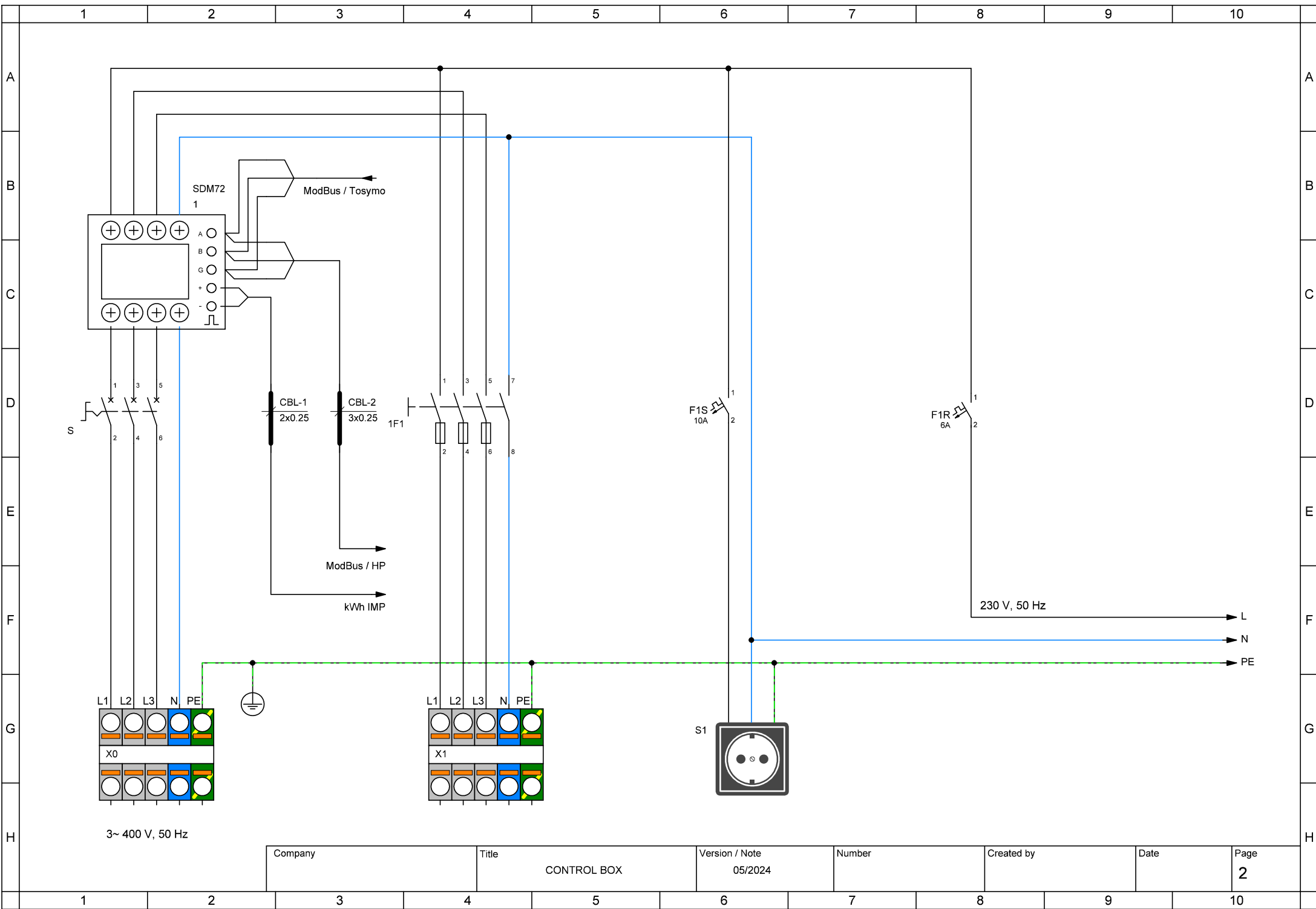

Company	Title	Version / Note	Number	Created by	Date	Page
	CONTROL BOX	05/2024				2



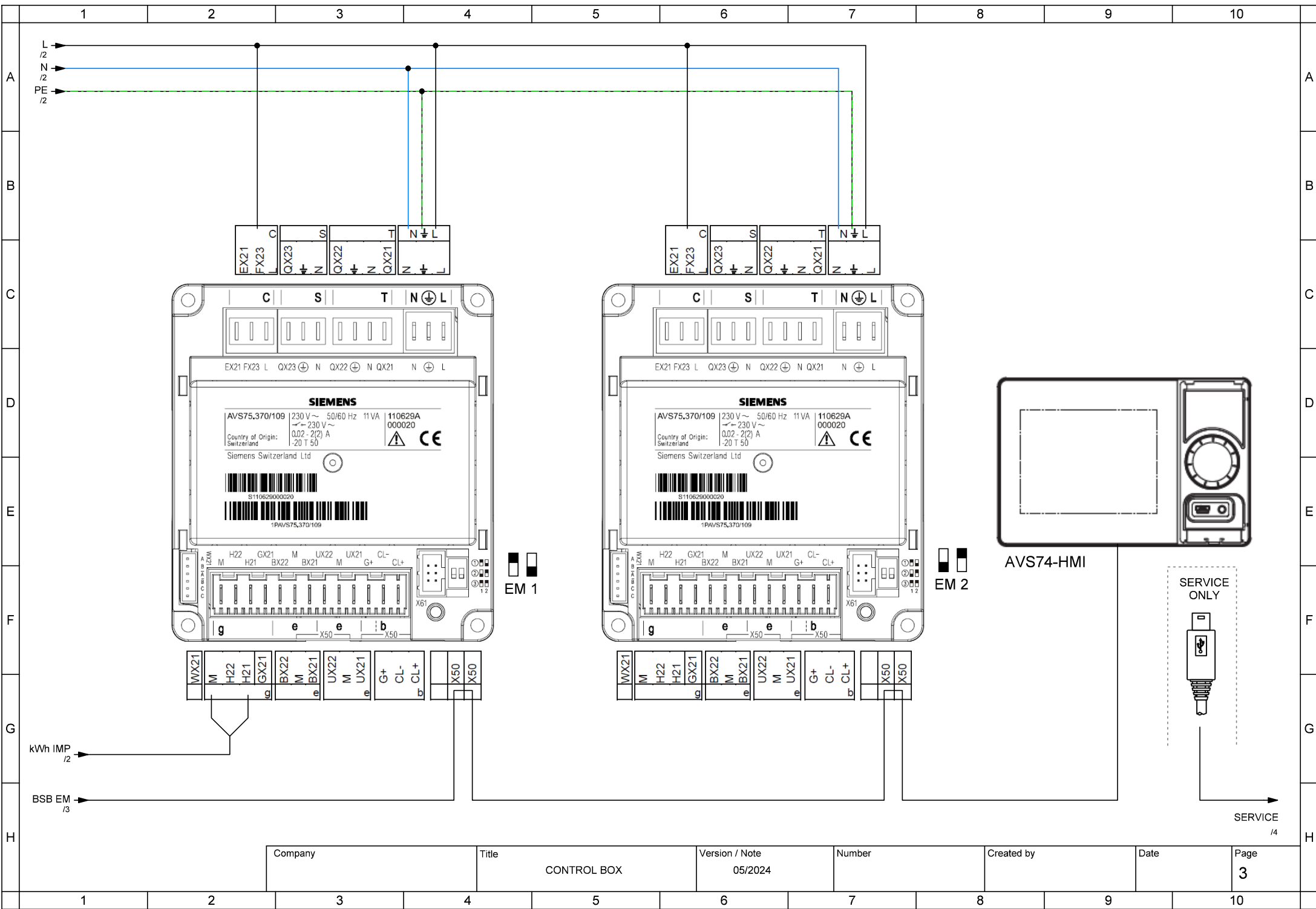

Company	Title	Version / Note	Number	Created by	Date	Page
	CONTROL BOX	05/2024				3

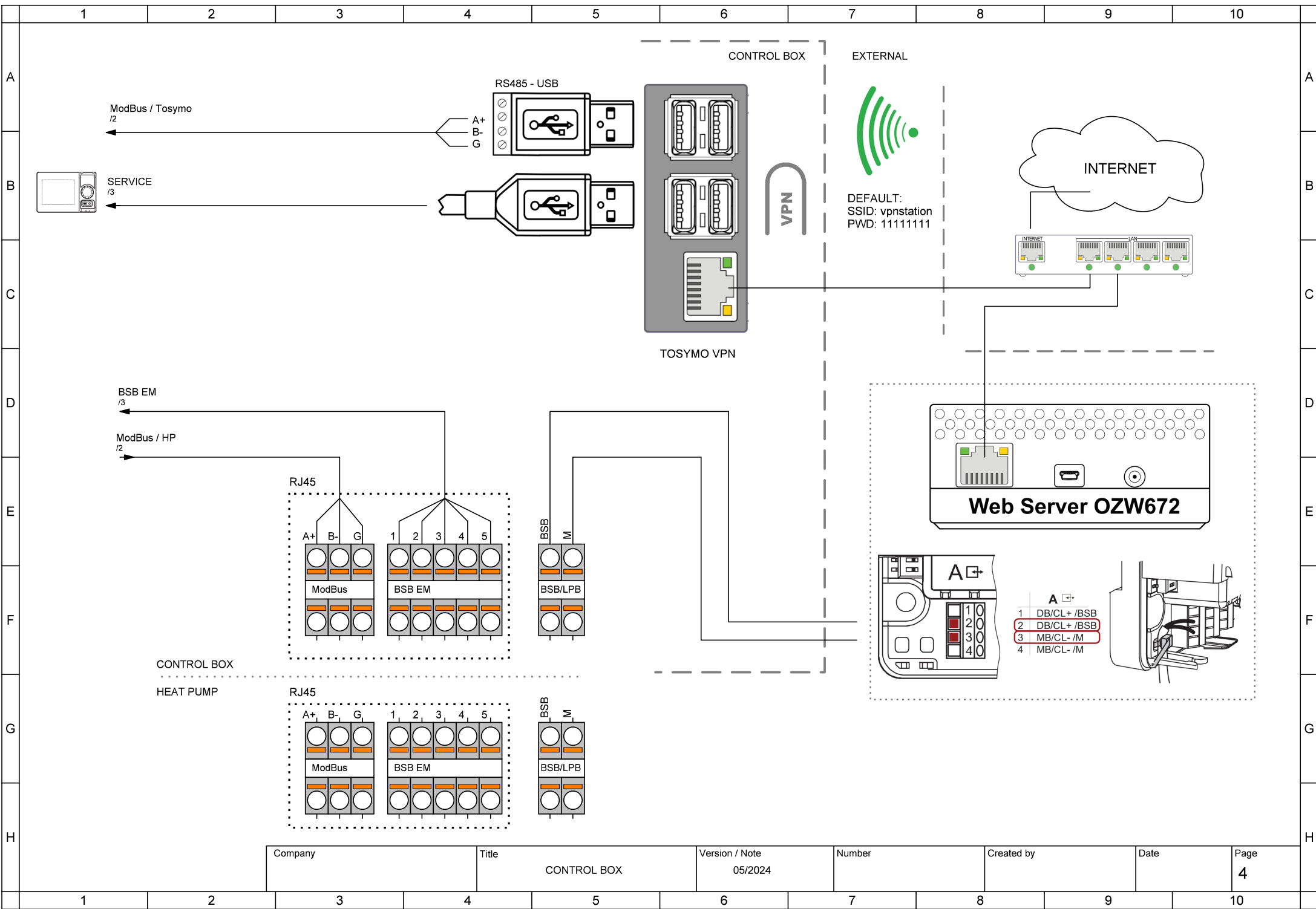

Company	Title	Version / Note	Number	Created by	Date	Page
	CONTROL BOX	05/2024				4



- AVS75.390
- AVS75.391
- AVS75.370

- AVS75.370**  
 Netzanschluss 230V / 50 Hz  
 Erde  
 Nullleiter  
**Y1** Mischer Auf  
  
**Y2** Mischer Zu  
  
**Q2** Heizkreispumpe HK1 Q2  
  
**L** Faze 230V  
**E61** Smart Grid E61

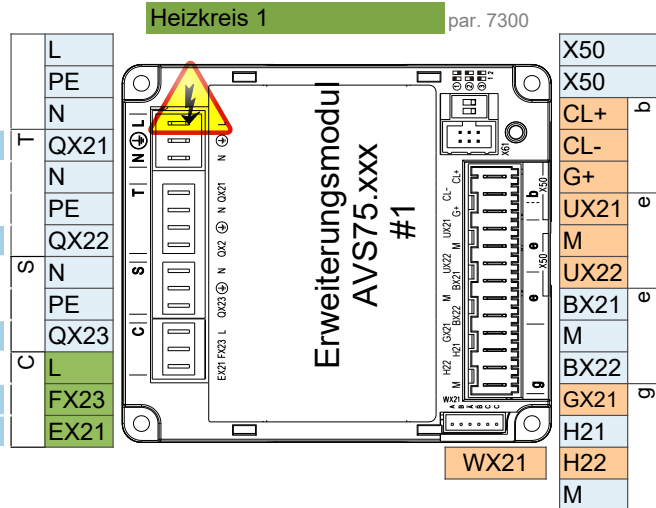

- Erweiterungsmodul AVS75.xxx  
 Raumgerät QAA...  
 Raumgerät QAA...

**B1** Vorlauffühler 1

Impulszählung

- AVS75.370**  
 Netzanschluss 230V / 50 Hz  
 Erde  
 Nullleiter  
**Q3** Trinkwasserstellglied Q3  
  
**K6** Elektroeinsatz TWW K6  
  
**Q6** Heizkreispumpe HK2 Q6  
  
**L** Faze 230V  
**E62** Smart Grid E62

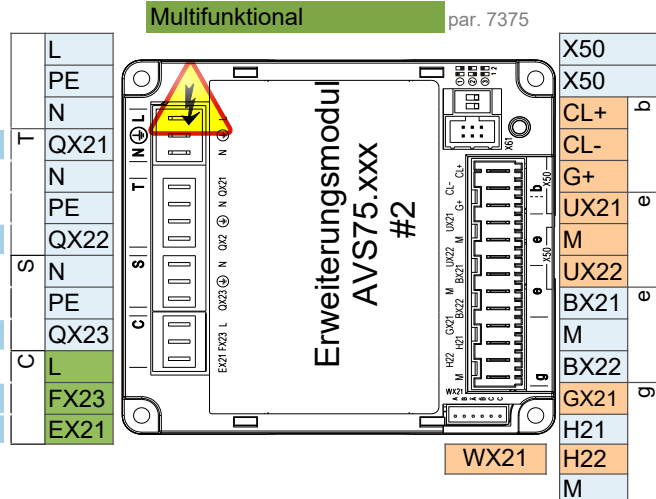

- Bediengerät (HMI) AVS37.xxx  
 Erweiterungsmodul AVS75.xxx  
 Raumgerät QAA...  
 Raumgerät QAA...

**B3** Trinkwasserfühler B3

**B4** Pufferspeicherfühler B4

- Netzanschluss 230V / 50 Hz  
 Erde  
 Nullleiter

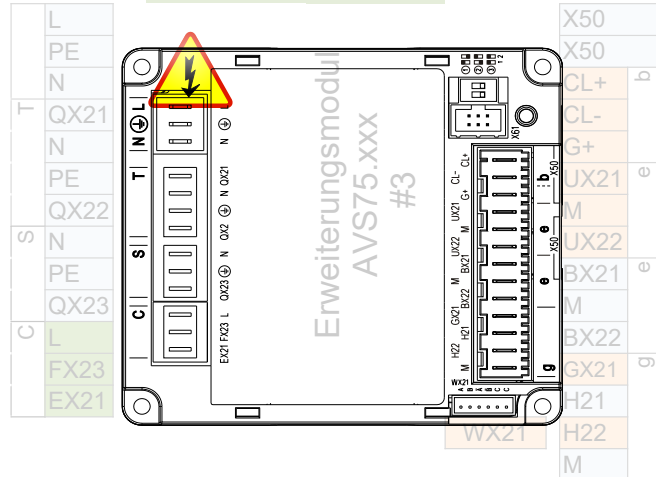

- Bediengerät (HMI) AVS37.xxx  
 Erweiterungsmodul AVS75.xxx  
 Raumgerät QAA...  
 Raumgerät QAA...

Vorsicht: Erweiterungsmodul 3 ist in der Wärmepumpe

## Anschlussmöglichkeiten für die Steuerung

### 1 ControlBox

---

ControlBox, mit zwei eingebauten Erweiterungsmodulen, ermöglicht zahlreiche Optionen für die Anwendungssteuerung auf der Verbraucherseite hinter der Wärmepumpe. Weitere Informationen finden Sie im Schaltplan der ControlBox und im Blatt mit den Anwendungsdiagrammen.

### 2 Fixer Sollwert Vorlauftemperatur - Ein / Aus potentialfreier Kontakt

---

2-adriges abgeschirmtes Kabel 2 x 0,5 mm<sup>2</sup> - Sollwert = 45°C (editierbar über Parameter 1859)

Anschlussklemme - siehe Schaltplan

### 3 Analog 0..10V Vorlauftemperatur-Sollwertregelung

---

2 Adern geschirmtes Kabel 2 x 0,5 mm<sup>2</sup> - Sollwert: 0V = 16°C ~ 10V = 60°C ( editierbar im Parametersatz )

Anschlussklemme - siehe Schaltplan

### 4 ModBus RTU-Kommunikationsbefehl

---

3-adriges abgeschirmtes Kabel min. 3 x 0,25mm<sup>2</sup>

Für die ModBus-Zuordnungstabelle wenden Sie sich bitte an den technischen Support

### 5 MQTT IoT-Kommunikationsprotokoll

---

Für weitere Informationen wenden Sie sich bitte an den technischen Support