

Basic performance data - WAMAK TWW 110 WHR HeavyDuty 2L1

| Heating - EN 14511 | | |
|--|-------------------|----------------------|
| Heating capacity [kW] | W10 / W35 (max) | 60.7 (30.4 / 60.7) |
| | W10 / W35 (min) | 30.4 (30.4 / 60.7) |
| | W10 / W34 | 61.1 (30.5 / 61.1) |
| Electrical power input [kW] | W10 / W35 (max) | 10.3 (5.1 / 10.3) |
| | W10 / W35 (min) | 5.1 (5.1 / 10.3) |
| | W10 / W34 | 10.1 (5.0 / 10.1) |
| Heating efficiency faktor [COP] | W10 / W35 (max) | 5.89 |
| | W10 / W35 (min) | 6.00 |
| | W10 / W34 | 6.04 |
| Seasonal space heating energy efficiency - SCOP EN 14825 | | |
| Average Climate / Low Temperature [35°C] | SCOP | 6.66 |
| | η [%] | 266.5 |
| | Label | A+++ |
| | Qhe [kWh] | 18475.0 |
| | Pdesignh [kW] | 60.7 |
| | Tbivalent [°C] | -7 |
| Cooling | | |
| Cooling capacity - [kW] | A35 / W23-18 | 46.0 |
| | A25 / W23-18 | 51.7 |
| | A35 / W12-7 | 29.9 |
| | A25 / W12-7 | 29.9 |
| Seasonal space cooling energy efficiency - SEER EN 14825 | | |
| [W 23 / 18°C] | SEER | 5.30 |
| | Qce [kWh] | 17940.0 |
| | η_c [%] | 212.1 |
| Sound EN 12102 | | |
| Acoustic power - Lw | dB(A) | 61.6 |
| Acoustic pressure - Lp | 1 m dB(A) | 53.6 |
| | 5 m dB(A) | 39.6 |
| | 10 m dB(A) | 33.6 |
| Mechanical and operational information | | |
| Compressor type (3~ 400/50) | SCROLL / 2 / | On/Off |
| Refrigerant | R513A (GWP - 631) | 11.2 kg |
| Operating limit temperatures heating - (min / max) [°C] | | 45 / 85 |
| Operating limit temperatures source - (min / max) [°C] | | -10 / 50 |
| Weight | | 620 kg |

Main technical data - WAMAK TWW 110 WHR HeavyDuty 2L1

| Enclosure type | | HD2L1 | | Heat energy rejection side data | | |
|--|--------------------|------------|--|--|--------------|--------------|
| Basic dimensions | Height [mm] | 2000 | | Operating limit temperatures heating | MAX [°C] | 85 |
| | Width [mm] | 820 | | | MIN [°C] | 45 |
| | Length [mm] | 1200 | | for more see operating limits diagram | | |
| Weight [kg] | 620 | | Condenser | Port size | VIC 2.1/2 " | |
| Colour | Gray | | | Type | BPHE | |
| Enclosure IP Class | IP20 | | | Count | 1 | |
| Refrigeration cycle | | | | Material | AISI 316 | |
| Compressor | Type | Scroll | | Maximal operating pressure - refrigerant [bar] | | 32 |
| | Number of stages | 2 | | Maximal operating pressure - Water [bar] | | 6 |
| | On/Off | | | Testing pressure [bar] | | 70 |
| | Power factor Cosφ | 0.63 | | Heat transfer medium | | Water |
| | Winding resistance | 1.23 Ohm | | Volume flow @ dT 5K (nom) - Water [m3/h] | | 7.28 ~ 14.55 |
| Refrigerant | | R513A | | Internal pressure drop - Water [kPa] | | 20 |
| | Volme | 11.2 kg | | Temperature difference | @ 35°C (nom) | 5 K |
| | GWP | 631 | | | @ 55°C | 8 K |
| | Safety class | A1 | | | @ 65°C | 10 K |
| Refrigeration oil type | POE RL32-3MAF | | Renewable energy extraction side data | | | |
| | Oil volume | 2 x 3.25 L | | Operating limit temperatures source | MIN [°C] | -10 |
| Maximal pressure - refrigerant [bar] | 32 | | for more see operating limits diagram | | | |
| | PED class | 2 | | Evaporator | MAX [°C] | 50 |
| EVI - vapour injection with economizer | | | Port size | | VIC 2.1/2 " | |
| Electrical connection data | | | Type | | BPHE | |
| Line voltage [#~ V/Hz] | 3~ 400/50 | | Count | 1 | | |
| Current | nominal [A] | 34.44 | | Material | AISI 316 | |
| | maximal [A] | 44.60 | | Maximal operating pressure - refrigerant [bar] | | 20 |
| | starting [A] | 12.9 | | Heat transfer medium | | Water |
| Softstart | - | | Maximal operating pressure - Water [bar] | | 6 | |
| Main safety | C80 | | Volume flow - Water [m3/h] | | 6.84 ~ 13.69 | |
| Control System | | | Internal pressure drop - Water [kPa] | | 20 | |
| Main controller | SIEMENS | RVS 61 | | Temperature difference - Water | | 4 K |
| Extension module | AVS75.3xx | AVS75.3xx | AVS75.372 | | | |
| Bus Clip-In | | | Modbus OCI352 | | | |
| Online connection | Web server OZW672 | | ToSyMo | | | |
| Superheat controller | | | SEC61 | | | |

*** with accessory

WAMAK TWW 110 WHR HeavyDuty 2L1

ErP (EU) No 811/2013: Technical parameters for heat pump space heaters

| Model | TWW 110 WHR HeavyDuty 2L1 |
|--------------------------------------|---------------------------|
| Air-to-water heat pump | no |
| Brine-to-water heat pump | no |
| Water-to-water heat pump | yes |
| Low-temperature heat pump | no |
| Equipped with a supplementary heater | no |
| Heat pump combination heater | no |
| Temperature application | low (35°C - 30°C) |
| Climate conditions | average |

| Item | Symbol | Value | Unit | Item | Symbol | Value | Unit |
|--|-----------------|---------|------|--|-------------|--------------|-------------------|
| Rated heat output at Tdesignh | Prated | 60.7 | kW | Seasonal space heating energy efficiency | η_s | 266.5 | % |
| Declared capacity for heating for part load at indoor temperature 20 °C and outdoor temperature Tj | | | | Declared coefficient of performance or primary energy ratio for part load at indoor temperature 20 °C and outdoor temperature Tj | | | |
| Tj = -7 °C | Pdh | 61.1 | kW | Tj = -7 °C | COPd | 6.04 | - |
| Tj = +2 °C | Pdh | 62.6 | kW | Tj = +2 °C | COPd | 6.6 | - |
| Tj = +7 °C | Pdh | 63.6 | kW | Tj = +7 °C | COPd | 7.3 | - |
| Tj = +12 °C | Pdh | 64.6 | kW | Tj = +12 °C | COPd | 7.8 | - |
| Tj = bivalent temperature | Pdh | 60.7 | kW | Tj = bivalent temperature | COPd | 5.9 | - |
| Tj = operation limit temperature | Pdh | --- | kW | Tj = operation limit temperature | COPd | --- | - |
| Bivalent temperature | Tbiv | -7 | °C | Tj = operation limit temperature | TOL | --- | °C |
| Power consumption in modes other than active mode | | | | Heating water operating limit temperature | WTOL | 85 | °C |
| Off mode | Poff | 0.040 | kW | Supplementary heater | | | |
| Thermostat-off mode | Pto | 0.010 | kW | Rated heat output | Psup | 11.5 | kW |
| Standby mode | Psb | 0.010 | kW | Type of energy input | electricity | | |
| Crankcase heater mode | Pck | 0.050 | kW | | | | |
| Other items | | | | For air-to-water heat pumps: Rated air flow rate, outdoors | - | --- | m ³ /h |
| Capacity control | multi-stage | | | For water- or brine-to-water heat pumps: Rated brine or water flow rate, outdoor heat exchanger | - | 6.84 ~ 13.69 | m ³ /h |
| Sound power level | | | | | | | |
| indoors | Lwa | 62 | dB | | | | |
| outdoors | Lwa | --- | dB | | | | |
| Annual energy consumption | Q _{HE} | 18475.0 | kWh | | | | |

Contact details: WAMAK, s.r.o., Orovnicna 252, 96652, Orovnicna, Slovakia, info@wamak.sk

WAMAK TWW 110 WHR HeavyDuty 2L1

ErP (EU) No 811/2013: Technical parameters for heat pump space heaters

| Model | TWW 110 WHR HeavyDuty 2L1 |
|--------------------------------------|---------------------------|
| Air-to-water heat pump | no |
| Brine-to-water heat pump | no |
| Water-to-water heat pump | yes |
| Low-temperature heat pump | no |
| Equipped with a supplementary heater | no |
| Heat pump combination heater | no |
| Temperature application | middle (55°C - 47°C) |
| Climate conditions | average |

| Item | Symbol | Value | Unit | Item | Symbol | Value | Unit |
|--|-----------------|-------------|------|--|----------|--------------|-------------------|
| Rated heat output at Tdesignh | Prated | 53.0 | kW | Seasonal space heating energy efficiency | η_s | 201.0 | % |
| Declared capacity for heating for part load at indoor temperature 20 °C and outdoor temperature Tj | | | | Declared coefficient of performance or primary energy ratio for part load at indoor temperature 20 °C and outdoor temperature Tj | | | |
| Tj = -7 °C | Pdh | 55.4 | kW | Tj = -7 °C | COPd | 3.97 | - |
| Tj = +2 °C | Pdh | 59.8 | kW | Tj = +2 °C | COPd | 5.3 | - |
| Tj = +7 °C | Pdh | 61.9 | kW | Tj = +7 °C | COPd | 6.2 | - |
| Tj = +12 °C | Pdh | 63.6 | kW | Tj = +12 °C | COPd | 6.9 | - |
| Tj = bivalent temperature | Pdh | 53.0 | kW | Tj = bivalent temperature | COPd | 3.5 | - |
| Tj = operation limit temperature | Pdh | --- | kW | Tj = operation limit temperature | COPd | --- | - |
| Bivalent temperature | Tbiv | -7 | °C | Tj = operation limit temperature | TOL | --- | °C |
| Power consumption in modes other than active mode | | | | Heating water operating limit temperature | WTOL | 85 | °C |
| Off mode | Poff | 0.040 | kW | Supplementary heater | | | |
| Thermostat-off mode | Pto | 0.010 | kW | Rated heat output | Psup | 11.5 | kW |
| Standby mode | Psb | 0.010 | kW | Type of energy input | | | electricity |
| Crankcase heater mode | Pck | 0.050 | kW | | | | |
| Other items | | | | For air-to-water heat pumps: Rated air flow rate, outdoors | - | --- | m ³ /h |
| Capacity control | | multi-stage | | For water- or brine-to-water heat pumps: Rated brine or water flow rate, outdoor heat exchanger | - | 6.84 ~ 13.69 | m ³ /h |
| Sound power level | | | | | | | |
| indoors | Lwa | 62 | dB | | | | |
| outdoors | Lwa | --- | dB | | | | |
| Annual energy consumption | Q _{HE} | 21444.7 | kWh | | | | |

Contact details: WAMAK, s.r.o., Orovnicna 252, 96652, Orovnicna, Slovakia, info@wamak.sk



ENERG Y IJA
 енергия - ενεργεια IE IA



TWW 110 WHR
 HeavyDuty 2L1



55 °C

35 °C



A+++

A+++



62 dB



--- dB

■ 56
 ■ 53
 ■ 52
 kW

■ 62
 ■ 61
 ■ 58
 kW



2019

811/2013

TWW 110 WHR
 HeavyDuty 2L1

ErP Data

| | 55 °C | 35 °C |
|---------------------|-------|-------|
| Energy class | A+++ | A+++ |
| η [%] | 201.0 | 266.5 |
| P_{rated} [kW] | 53 | 61 |
| Q_{HE} [kWh/y] | 21445 | 18475 |
| SCOP [-] | 5.03 | 6.66 |
| $T_{bivalent}$ [°C] | -7 | -7 |

CONTROLLER



+ QAA55/75
 - QAA55/75

class VII
 class III

3.5% ↓
 1.5% ↓

| Heating performance data | | Heat recovery | | |
|--------------------------|--|---------------|------|------|
| Operating conditions | | Qh | P | COP |
| W45 / W80 | | 113.2 | 25.3 | 4.47 |
| W30 / W70 | | 84.1 | 20.8 | 4.04 |
| W25 / W60 | | 93.6 | 17.2 | 5.45 |

Normative data: water - water application

Source - Water [10°C] / Low Temperature [35°C]

| Operating conditions | | Qh | P | COP |
|----------------------|----------------------|------|------|------|
| 1 | W10 / W30-35 | 60.7 | 10.3 | 5.89 |
| 2 | W10 / W30-35 (MIN) | 30.4 | 5.1 | 6.00 |
| A | W10 / Wxx-34 | 61.1 | 10.1 | 6.04 |
| B | W10 / Wxx-30 | 62.6 | 9.4 | 6.65 |
| C | W10 / Wxx-27 | 63.6 | 8.9 | 7.26 |
| D | W10 / Wxx-24 | 64.6 | 8.4 | 7.79 |
| E | W10 / Wxx-35 | 60.7 | 10.3 | 5.89 |
| F | W10 / Wxx-35 | 60.7 | 10.3 | 5.89 |

| SCOP DATA EN 14825:2018 | |
|---|--------|
| Source - Water [10°C] / Low Temperature [35°C] | |
| SCOPon | 6.79 |
| SCOPnet | 6.79 |
| SCOP | 6.66 |
| η [%] | 266.54 |
| Label | A+++ |
| Qh [kWh] | 18475 |
| Pdesignh [kW] | 60.7 |
| Tbivalent [°C] | -7.00 |

Source - Water [10°C] / Medium Temperature [55°C]

| Operating conditions | | Qh | P | COP |
|----------------------|----------------------|------|------|------|
| 1 | W10 / W47-55 | 53.0 | 15.1 | 3.50 |
| 2 | W10 / W47-55 (MIN) | 26.5 | 7.4 | 3.56 |
| A | W10 / Wxx-52 | 55.4 | 14.0 | 3.97 |
| B | W10 / Wxx-42 | 59.8 | 11.3 | 5.29 |
| C | W10 / Wxx-36 | 61.9 | 10.2 | 6.16 |
| D | W10 / Wxx-30 | 63.6 | 9.4 | 6.87 |
| E | W10 / Wxx-55 | 53.0 | 15.1 | 3.50 |
| F | W10 / Wxx-55 | 53.0 | 15.1 | 3.50 |

| SCOP DATA EN 14825:2018 | |
|--|--------|
| Source - Water [10°C] / Medium Temperature [55°C] | |
| SCOPon | 5.11 |
| SCOPnet | 5.11 |
| SCOP | 5.03 |
| η [%] | 201.01 |
| Label | A+++ |
| Qh [kWh] | 21445 |
| Pdesignh [kW] | 53.0 |
| Tbivalent [°C] | -7.00 |

Low temperature cooling W 12 / 7°C

| Operating conditions | | | | Qc | P | EER | SEER DATA EN 14825:2018 [W 12 / 7°C] | |
|----------------------|----------------|------|------|------|------------|--------|--|--|
| A | W30-35 / W12-7 | 32.2 | 10.9 | 2.95 | SEERon | 3.64 | | |
| B | W26-xx / W12-7 | 33.9 | 10.1 | 3.35 | SEER | 3.56 | | |
| C | W22-xx / W12-7 | 35.5 | 9.4 | 3.77 | Qc [kWh] | 17940 | | |
| D | W18-xx / W12-7 | 36.3 | 9.1 | 4.00 | η [%] | 142.41 | | |

Radiant cooling W 23 / 18°C

| Operating conditions | | | | Qc | P | EER | SEER DATA EN 14825:2018 [W 23 / 18°C] | |
|----------------------|-----------------|------|------|------|------------|--------|---|--|
| A | W50-xx / W23-18 | 36.2 | 16.4 | 2.21 | SEERon | 5.48 | | |
| B | W40-xx / W23-18 | 42.9 | 13.3 | 3.23 | SEER | 5.30 | | |
| C | W30-35 / W23-18 | 48.9 | 10.9 | 4.49 | Qc [kWh] | 17940 | | |
| D | W26-xx / W23-18 | 51.2 | 10.1 | 5.06 | η [%] | 212.07 | | |

Performance lines - heating

- Qh-nom-35
- Qh-nom-55
- Qh-nom-60
- Qh-nom-70
- Qh-nom-80
- - - Qh-min-70

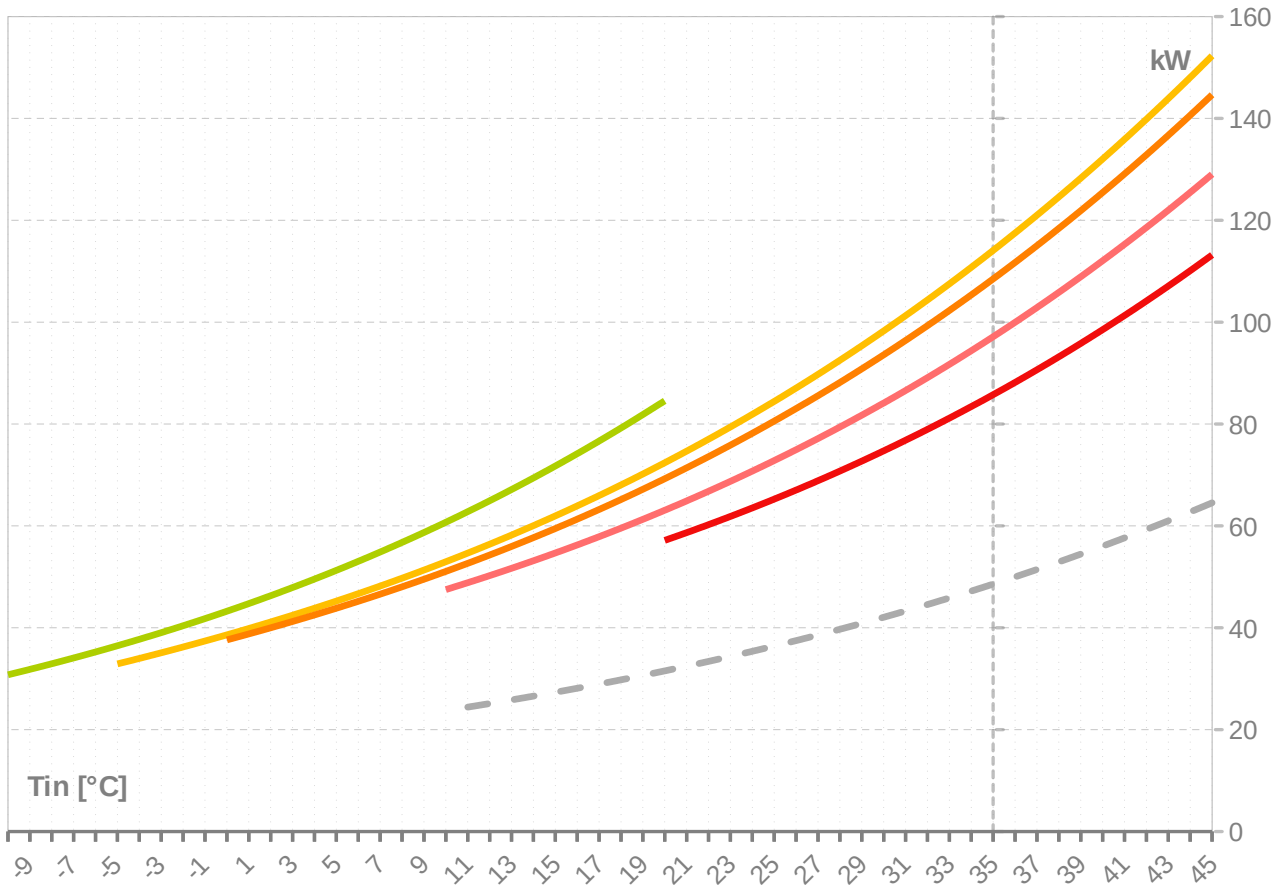

Performance lines - cooling

- Qc-nom-12-7
- Qc-nom-23-18

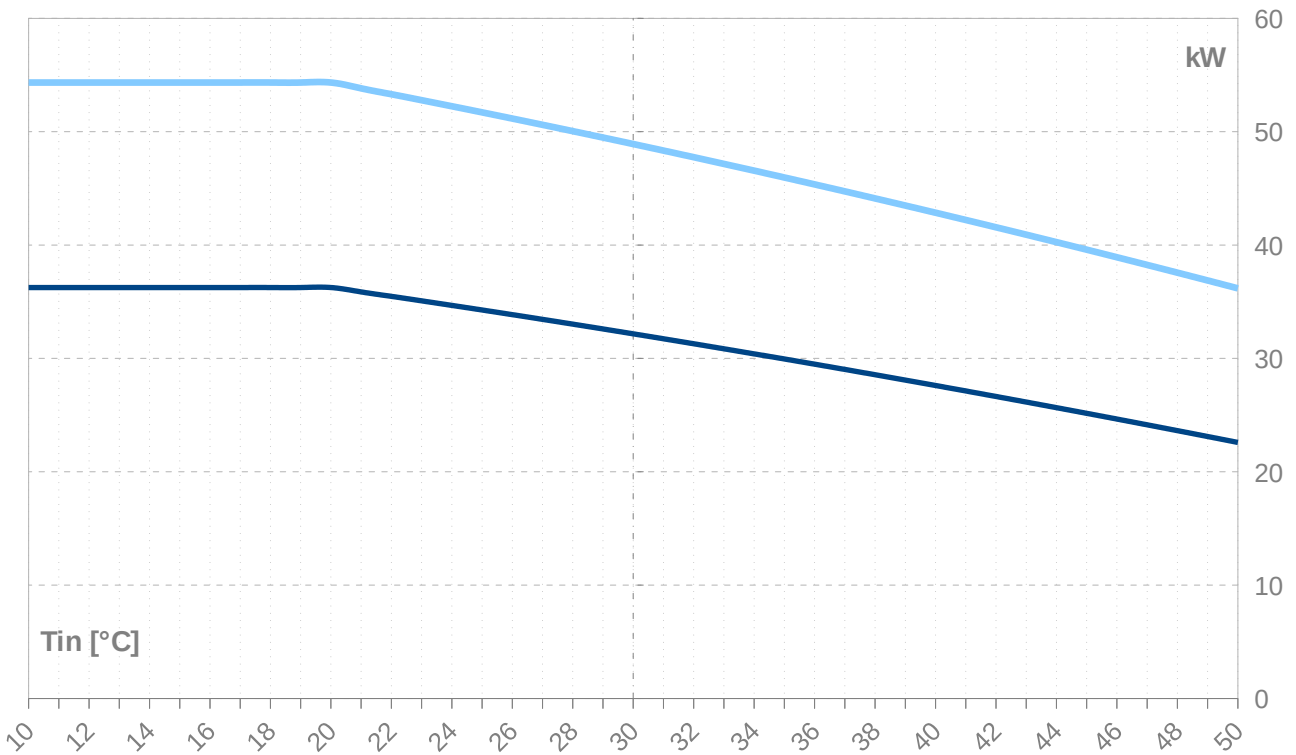

WAMAK TWW 110 WHR HeavyDuty 2L1

| Th -OU | 55 | | | | | | | | | | |
|-----------|--------------|-----------|-----------|-------------|------------|------------|-------------|-----------|-----------|-----------|----------|
| [°C] | Qh nom | Qh min | Qh max | Pin nom | Pin min | Pin max | COP nom | Qc nom | Qc min | Qc max | I nom |
| [°C] | [kW] | [kW] | [kW] | [kW] | [kW] | [kW] | kw / kw | [kW] | [kW] | [kW] | [A] |
| 45 | 152.3 | 76.1 | 152.3 | 16.3 | 8.0 | 16.3 | 9.32 | 137.1 | 68.6 | 137.1 | 29.3 |
| 44 | 148.0 | 74.0 | 148.0 | 16.3 | 8.0 | 16.3 | 9.09 | 132.9 | 66.5 | 132.9 | 29.3 |
| 43 | 143.9 | 71.9 | 143.9 | 16.2 | 8.0 | 16.2 | 8.86 | 128.8 | 64.4 | 128.8 | 29.2 |
| 42 | 139.8 | 69.9 | 139.8 | 16.2 | 8.0 | 16.2 | 8.64 | 124.8 | 62.4 | 124.8 | 29.1 |
| 41 | 135.9 | 67.9 | 135.9 | 16.1 | 7.9 | 16.1 | 8.42 | 120.9 | 60.5 | 120.9 | 29.1 |
| 40 | 132.0 | 66.0 | 132.0 | 16.1 | 7.9 | 16.1 | 8.21 | 117.1 | 58.6 | 117.1 | 29.0 |
| 39 | 128.3 | 64.1 | 128.3 | 16.0 | 7.9 | 16.0 | 8.00 | 113.4 | 56.7 | 113.4 | 29.0 |
| 38 | 124.6 | 62.3 | 124.6 | 16.0 | 7.9 | 16.0 | 7.79 | 109.8 | 54.9 | 109.8 | 28.9 |
| 37 | 121.0 | 60.5 | 121.0 | 15.9 | 7.8 | 15.9 | 7.59 | 106.2 | 53.1 | 106.2 | 28.8 |
| 36 | 117.5 | 58.7 | 117.5 | 15.9 | 7.8 | 15.9 | 7.39 | 102.8 | 51.4 | 102.8 | 28.8 |
| 35 | 114.1 | 57.0 | 114.1 | 15.9 | 7.8 | 15.9 | 7.20 | 99.4 | 49.7 | 99.4 | 28.7 |
| 34 | 110.8 | 55.4 | 110.8 | 15.8 | 7.8 | 15.8 | 7.00 | 96.1 | 48.0 | 96.1 | 28.7 |
| 33 | 107.5 | 53.8 | 107.5 | 15.8 | 7.8 | 15.8 | 6.82 | 92.9 | 46.4 | 92.9 | 28.6 |
| 32 | 104.4 | 52.2 | 104.4 | 15.7 | 7.7 | 15.7 | 6.63 | 89.8 | 44.9 | 89.8 | 28.6 |
| 31 | 101.3 | 50.6 | 101.3 | 15.7 | 7.7 | 15.7 | 6.45 | 86.7 | 43.4 | 86.7 | 28.5 |
| 30 | 98.3 | 49.1 | 98.3 | 15.7 | 7.7 | 15.7 | 6.28 | 83.8 | 41.9 | 83.8 | 28.5 |
| 29 | 95.4 | 47.7 | 95.4 | 15.6 | 7.7 | 15.6 | 6.11 | 80.9 | 40.4 | 80.9 | 28.5 |
| 28 | 92.5 | 46.3 | 92.5 | 15.6 | 7.7 | 15.6 | 5.94 | 78.1 | 39.0 | 78.1 | 28.4 |
| 27 | 89.8 | 44.9 | 89.8 | 15.5 | 7.6 | 15.5 | 5.77 | 75.3 | 37.7 | 75.3 | 28.4 |
| 26 | 87.1 | 43.5 | 87.1 | 15.5 | 7.6 | 15.5 | 5.61 | 72.7 | 36.3 | 72.7 | 28.3 |
| 25 | 84.4 | 42.2 | 84.4 | 15.5 | 7.6 | 15.5 | 5.45 | 70.1 | 35.0 | 70.1 | 28.3 |
| 24 | 81.9 | 40.9 | 81.9 | 15.4 | 7.6 | 15.4 | 5.30 | 67.6 | 33.8 | 67.6 | 28.3 |
| 23 | 79.4 | 39.7 | 79.4 | 15.4 | 7.6 | 15.4 | 5.15 | 65.1 | 32.6 | 65.1 | 28.2 |
| 22 | 77.0 | 38.5 | 77.0 | 15.4 | 7.6 | 15.4 | 5.00 | 62.7 | 31.4 | 62.7 | 28.2 |
| 21 | 74.7 | 37.3 | 74.7 | 15.4 | 7.6 | 15.4 | 4.86 | 60.4 | 30.2 | 60.4 | 28.2 |
| 20 | 72.4 | 36.2 | 72.4 | 15.3 | 7.5 | 15.3 | 4.72 | 58.2 | 29.1 | 58.2 | 28.1 |
| 19 | 70.2 | 35.1 | 70.2 | 15.3 | 7.5 | 15.3 | 4.58 | 56.0 | 28.0 | 56.0 | 28.1 |
| 18 | 68.0 | 34.0 | 68.0 | 15.3 | 7.5 | 15.3 | 4.45 | 53.9 | 26.9 | 53.9 | 28.1 |
| 17 | 65.9 | 33.0 | 65.9 | 15.3 | 7.5 | 15.3 | 4.32 | 51.8 | 25.9 | 51.8 | 28.0 |
| 16 | 63.9 | 32.0 | 63.9 | 15.2 | 7.5 | 15.2 | 4.19 | 49.8 | 24.9 | 49.8 | 28.0 |
| 15 | 62.0 | 31.0 | 62.0 | 15.2 | 7.5 | 15.2 | 4.07 | 47.8 | 23.9 | 47.8 | 28.0 |
| 14 | 60.0 | 30.0 | 60.0 | 15.2 | 7.5 | 15.2 | 3.95 | 45.9 | 23.0 | 45.9 | 28.0 |
| 13 | 58.2 | 29.1 | 58.2 | 15.2 | 7.5 | 15.2 | 3.83 | 44.1 | 22.1 | 44.1 | 27.9 |
| 12 | 56.4 | 28.2 | 56.4 | 15.2 | 7.5 | 15.2 | 3.72 | 42.3 | 21.2 | 42.3 | 27.9 |
| 11 | 54.7 | 27.3 | 54.7 | 15.2 | 7.4 | 15.2 | 3.61 | 40.6 | 20.3 | 40.6 | 27.9 |
| 10 | 53.0 | 26.5 | 53.0 | 15.1 | 7.4 | 15.1 | 3.50 | 38.9 | 19.5 | 38.9 | 27.9 |
| 9 | 51.3 | 25.7 | 51.3 | 15.1 | 7.4 | 15.1 | 3.39 | 37.3 | 18.6 | 37.3 | 27.9 |
| 8 | 49.7 | 24.9 | 49.7 | 15.1 | 7.4 | 15.1 | 3.29 | 35.7 | 17.9 | 35.7 | 27.9 |
| 7 | 48.2 | 24.1 | 48.2 | 15.1 | 7.4 | 15.1 | 3.19 | 34.2 | 17.1 | 34.2 | 27.9 |
| 6 | 46.7 | 23.3 | 46.7 | 15.1 | 7.4 | 15.1 | 3.09 | 32.7 | 16.3 | 32.7 | 27.8 |
| 5 | 45.2 | 22.6 | 45.2 | 15.1 | 7.4 | 15.1 | 3.00 | 31.3 | 15.6 | 31.3 | 27.8 |
| 4 | 43.8 | 21.9 | 43.8 | 15.1 | 7.4 | 15.1 | 2.91 | 29.9 | 14.9 | 29.9 | 27.8 |
| 3 | 42.5 | 21.2 | 42.5 | 15.1 | 7.4 | 15.1 | 2.82 | 28.5 | 14.2 | 28.5 | 27.8 |
| 2 | 41.1 | 20.6 | 41.1 | 15.1 | 7.4 | 15.1 | 2.73 | 27.2 | 13.6 | 27.2 | 27.8 |
| 1 | 39.9 | 19.9 | 39.9 | 15.1 | 7.4 | 15.1 | 2.65 | 25.9 | 12.9 | 25.9 | 27.8 |
| 0 | 38.6 | 19.3 | 38.6 | 15.1 | 7.4 | 15.1 | 2.57 | 24.6 | 12.3 | 24.6 | 27.8 |
| -1 | 37.4 | 18.7 | 37.4 | 15.0 | 7.4 | 15.0 | 2.48 | 23.4 | 11.7 | 23.4 | 27.8 |
| -2 | 36.2 | 18.1 | 36.2 | 15.0 | 7.4 | 15.0 | 2.41 | 22.3 | 11.1 | 22.3 | 27.8 |
| -3 | 35.1 | 17.5 | 35.1 | 15.0 | 7.4 | 15.0 | 2.33 | 21.1 | 10.6 | 21.1 | 27.8 |
| -4 | 34.0 | 17.0 | 34.0 | 15.1 | 7.4 | 15.1 | 2.26 | 20.0 | 10.0 | 20.0 | 27.8 |
| -5 | 32.9 | 16.4 | 32.9 | 15.1 | 7.4 | 15.1 | 2.19 | 18.9 | 9.5 | 18.9 | 27.8 |

-- attention: operating limits not reflected in performance table

ZR144KRE-TFD_R513A_2_WHR

WAMAK TWW 110 WHR HeavyDuty 2L1

| Th -OU | 60 | | | | | | | | | | |
|-----------|--------------|-----------|-----------|-------------|------------|------------|-------------|-----------|-----------|-----------|----------|
| [°C] | Qh nom | Qh min | Qh max | Pin nom | Pin min | Pin max | COP nom | Qc nom | Qc min | Qc max | I nom |
| [°C] | [kW] | [kW] | [kW] | [kW] | [kW] | [kW] | kw / kw | [kW] | [kW] | [kW] | [A] |
| 45 | 144.6 | 72.3 | 144.6 | 17.7 | 8.7 | 17.7 | 8.16 | 128.2 | 64.1 | 128.2 | 31.0 |
| 44 | 140.6 | 70.3 | 140.6 | 17.7 | 8.7 | 17.7 | 7.95 | 124.2 | 62.1 | 124.2 | 31.0 |
| 43 | 136.7 | 68.3 | 136.7 | 17.6 | 8.7 | 17.6 | 7.75 | 120.3 | 60.2 | 120.3 | 30.9 |
| 42 | 132.8 | 66.4 | 132.8 | 17.6 | 8.6 | 17.6 | 7.55 | 116.5 | 58.3 | 116.5 | 30.8 |
| 41 | 129.1 | 64.6 | 129.1 | 17.6 | 8.6 | 17.6 | 7.36 | 112.8 | 56.4 | 112.8 | 30.8 |
| 40 | 125.5 | 62.7 | 125.5 | 17.5 | 8.6 | 17.5 | 7.16 | 109.2 | 54.6 | 109.2 | 30.7 |
| 39 | 121.9 | 60.9 | 121.9 | 17.5 | 8.6 | 17.5 | 6.98 | 105.7 | 52.8 | 105.7 | 30.7 |
| 38 | 118.4 | 59.2 | 118.4 | 17.4 | 8.6 | 17.4 | 6.79 | 102.2 | 51.1 | 102.2 | 30.7 |
| 37 | 115.0 | 57.5 | 115.0 | 17.4 | 8.6 | 17.4 | 6.61 | 98.9 | 49.4 | 98.9 | 30.6 |
| 36 | 111.7 | 55.9 | 111.7 | 17.4 | 8.5 | 17.4 | 6.44 | 95.6 | 47.8 | 95.6 | 30.6 |
| 35 | 108.5 | 54.2 | 108.5 | 17.3 | 8.5 | 17.3 | 6.26 | 92.4 | 46.2 | 92.4 | 30.5 |
| 34 | 105.4 | 52.7 | 105.4 | 17.3 | 8.5 | 17.3 | 6.09 | 89.3 | 44.7 | 89.3 | 30.5 |
| 33 | 102.3 | 51.1 | 102.3 | 17.3 | 8.5 | 17.3 | 5.93 | 86.3 | 43.1 | 86.3 | 30.4 |
| 32 | 99.3 | 49.7 | 99.3 | 17.2 | 8.5 | 17.2 | 5.77 | 83.3 | 41.7 | 83.3 | 30.4 |
| 31 | 96.4 | 48.2 | 96.4 | 17.2 | 8.5 | 17.2 | 5.61 | 80.5 | 40.2 | 80.5 | 30.4 |
| 30 | 93.6 | 46.8 | 93.6 | 17.2 | 8.4 | 17.2 | 5.45 | 77.7 | 38.8 | 77.7 | 30.3 |
| 29 | 90.8 | 45.4 | 90.8 | 17.1 | 8.4 | 17.1 | 5.30 | 74.9 | 37.5 | 74.9 | 30.3 |
| 28 | 88.2 | 44.1 | 88.2 | 17.1 | 8.4 | 17.1 | 5.15 | 72.3 | 36.1 | 72.3 | 30.3 |
| 27 | 85.6 | 42.8 | 85.6 | 17.1 | 8.4 | 17.1 | 5.01 | 69.7 | 34.9 | 69.7 | 30.2 |
| 26 | 83.0 | 41.5 | 83.0 | 17.1 | 8.4 | 17.1 | 4.87 | 67.2 | 33.6 | 67.2 | 30.2 |
| 25 | 80.6 | 40.3 | 80.6 | 17.0 | 8.4 | 17.0 | 4.73 | 64.8 | 32.4 | 64.8 | 30.2 |
| 24 | 78.2 | 39.1 | 78.2 | 17.0 | 8.4 | 17.0 | 4.60 | 62.4 | 31.2 | 62.4 | 30.1 |
| 23 | 75.8 | 37.9 | 75.8 | 17.0 | 8.3 | 17.0 | 4.47 | 60.1 | 30.0 | 60.1 | 30.1 |
| 22 | 73.6 | 36.8 | 73.6 | 17.0 | 8.3 | 17.0 | 4.34 | 57.9 | 28.9 | 57.9 | 30.1 |
| 21 | 71.4 | 35.7 | 71.4 | 16.9 | 8.3 | 16.9 | 4.21 | 55.7 | 27.8 | 55.7 | 30.1 |
| 20 | 69.3 | 34.6 | 69.3 | 16.9 | 8.3 | 16.9 | 4.09 | 53.6 | 26.8 | 53.6 | 30.0 |
| 19 | 67.2 | 33.6 | 67.2 | 16.9 | 8.3 | 16.9 | 3.97 | 51.5 | 25.7 | 51.5 | 30.0 |
| 18 | 65.2 | 32.6 | 65.2 | 16.9 | 8.3 | 16.9 | 3.86 | 49.5 | 24.8 | 49.5 | 30.0 |
| 17 | 63.2 | 31.6 | 63.2 | 16.9 | 8.3 | 16.9 | 3.75 | 47.6 | 23.8 | 47.6 | 30.0 |
| 16 | 61.3 | 30.7 | 61.3 | 16.9 | 8.3 | 16.9 | 3.64 | 45.7 | 22.8 | 45.7 | 30.0 |
| 15 | 59.5 | 29.7 | 59.5 | 16.8 | 8.3 | 16.8 | 3.53 | 43.9 | 21.9 | 43.9 | 30.0 |
| 14 | 57.7 | 28.8 | 57.7 | 16.8 | 8.3 | 16.8 | 3.43 | 42.1 | 21.0 | 42.1 | 29.9 |
| 13 | 56.0 | 28.0 | 56.0 | 16.8 | 8.3 | 16.8 | 3.33 | 40.4 | 20.2 | 40.4 | 29.9 |
| 12 | 54.3 | 27.1 | 54.3 | 16.8 | 8.3 | 16.8 | 3.23 | 38.7 | 19.3 | 38.7 | 29.9 |
| 11 | 52.6 | 26.3 | 52.6 | 16.8 | 8.3 | 16.8 | 3.13 | 37.1 | 18.5 | 37.1 | 29.9 |
| 10 | 51.1 | 25.5 | 51.1 | 16.8 | 8.3 | 16.8 | 3.04 | 35.5 | 17.7 | 35.5 | 29.9 |
| 9 | 49.5 | 24.8 | 49.5 | 16.8 | 8.3 | 16.8 | 2.95 | 34.0 | 17.0 | 34.0 | 29.9 |
| 8 | 48.0 | 24.0 | 48.0 | 16.8 | 8.2 | 16.8 | 2.86 | 32.5 | 16.2 | 32.5 | 29.9 |
| 7 | 46.6 | 23.3 | 46.6 | 16.8 | 8.2 | 16.8 | 2.78 | 31.0 | 15.5 | 31.0 | 29.9 |
| 6 | 45.2 | 22.6 | 45.2 | 16.8 | 8.2 | 16.8 | 2.69 | 29.6 | 14.8 | 29.6 | 29.9 |
| 5 | 43.8 | 21.9 | 43.8 | 16.8 | 8.2 | 16.8 | 2.61 | 28.3 | 14.1 | 28.3 | 29.9 |
| 4 | 42.5 | 21.3 | 42.5 | 16.8 | 8.2 | 16.8 | 2.54 | 27.0 | 13.5 | 27.0 | 29.9 |
| 3 | 41.2 | 20.6 | 41.2 | 16.8 | 8.2 | 16.8 | 2.46 | 25.7 | 12.8 | 25.7 | 29.9 |
| 2 | 40.0 | 20.0 | 40.0 | 16.8 | 8.2 | 16.8 | 2.39 | 24.4 | 12.2 | 24.4 | 29.9 |
| 1 | 38.8 | 19.4 | 38.8 | 16.8 | 8.2 | 16.8 | 2.31 | 23.2 | 11.6 | 23.2 | 29.9 |
| 0 | 37.6 | 18.8 | 37.6 | 16.8 | 8.2 | 16.8 | 2.24 | 22.1 | 11.0 | 22.1 | 29.9 |
| -1 | | | | | | | | | | | |
| -2 | | | | | | | | | | | |
| -3 | | | | | | | | | | | |
| -4 | | | | | | | | | | | |
| -5 | | | | | | | | | | | |

-- attention: operating limits not reflected in performance table

WAMAK TWW 110 WHR HeavyDuty 2L1

| Th -OU | [°C] | 70 | | | | | | | | | |
|-----------|--------------|-------------------|-------------------|-------------------|-------------------|--------------------|--------------------|--------------------|-----------------------|-------------------|-------------------|
| | | Ts -IN [°C] | Qh nom [kW] | Qh min [kW] | Qh max [kW] | Pin nom [kW] | Pin min [kW] | Pin max [kW] | COP nom kW / kW | Qc nom [kW] | Qc min [kW] |
| 45 | 129.0 | 64.5 | 129.0 | 21.0 | 10.3 | 21.0 | 6.13 | 109.5 | 54.8 | 109.5 | 35.3 |
| 44 | 125.5 | 62.7 | 125.5 | 21.0 | 10.3 | 21.0 | 5.97 | 106.0 | 53.0 | 106.0 | 35.2 |
| 43 | 122.0 | 61.0 | 122.0 | 21.0 | 10.3 | 21.0 | 5.81 | 102.5 | 51.3 | 102.5 | 35.2 |
| 42 | 118.6 | 59.3 | 118.6 | 21.0 | 10.3 | 21.0 | 5.65 | 99.1 | 49.6 | 99.1 | 35.2 |
| 41 | 115.3 | 57.6 | 115.3 | 21.0 | 10.3 | 21.0 | 5.50 | 95.8 | 47.9 | 95.8 | 35.2 |
| 40 | 112.1 | 56.0 | 112.1 | 20.9 | 10.3 | 20.9 | 5.35 | 92.6 | 46.3 | 92.6 | 35.1 |
| 39 | 108.9 | 54.5 | 108.9 | 20.9 | 10.3 | 20.9 | 5.20 | 89.5 | 44.7 | 89.5 | 35.1 |
| 38 | 105.9 | 52.9 | 105.9 | 20.9 | 10.3 | 20.9 | 5.06 | 86.4 | 43.2 | 86.4 | 35.1 |
| 37 | 102.9 | 51.4 | 102.9 | 20.9 | 10.3 | 20.9 | 4.92 | 83.5 | 41.7 | 83.5 | 35.1 |
| 36 | 100.0 | 50.0 | 100.0 | 20.9 | 10.3 | 20.9 | 4.79 | 80.6 | 40.3 | 80.6 | 35.1 |
| 35 | 97.1 | 48.6 | 97.1 | 20.9 | 10.3 | 20.9 | 4.65 | 77.8 | 38.9 | 77.8 | 35.0 |
| 34 | 94.4 | 47.2 | 94.4 | 20.9 | 10.3 | 20.9 | 4.52 | 75.0 | 37.5 | 75.0 | 35.0 |
| 33 | 91.7 | 45.9 | 91.7 | 20.9 | 10.2 | 20.9 | 4.40 | 72.4 | 36.2 | 72.4 | 35.0 |
| 32 | 89.1 | 44.6 | 89.1 | 20.8 | 10.2 | 20.8 | 4.28 | 69.8 | 34.9 | 69.8 | 35.0 |
| 31 | 86.6 | 43.3 | 86.6 | 20.8 | 10.2 | 20.8 | 4.16 | 67.3 | 33.6 | 67.3 | 35.0 |
| 30 | 84.1 | 42.1 | 84.1 | 20.8 | 10.2 | 20.8 | 4.04 | 64.8 | 32.4 | 64.8 | 35.0 |
| 29 | 81.7 | 40.9 | 81.7 | 20.8 | 10.2 | 20.8 | 3.93 | 62.4 | 31.2 | 62.4 | 35.0 |
| 28 | 79.4 | 39.7 | 79.4 | 20.8 | 10.2 | 20.8 | 3.82 | 60.1 | 30.1 | 60.1 | 35.0 |
| 27 | 77.1 | 38.6 | 77.1 | 20.8 | 10.2 | 20.8 | 3.71 | 57.9 | 28.9 | 57.9 | 34.9 |
| 26 | 74.9 | 37.5 | 74.9 | 20.8 | 10.2 | 20.8 | 3.60 | 55.7 | 27.8 | 55.7 | 34.9 |
| 25 | 72.8 | 36.4 | 72.8 | 20.8 | 10.2 | 20.8 | 3.50 | 53.5 | 26.8 | 53.5 | 34.9 |
| 24 | 70.7 | 35.4 | 70.7 | 20.8 | 10.2 | 20.8 | 3.40 | 51.5 | 25.7 | 51.5 | 34.9 |
| 23 | 68.7 | 34.4 | 68.7 | 20.8 | 10.2 | 20.8 | 3.31 | 49.5 | 24.7 | 49.5 | 34.9 |
| 22 | 66.8 | 33.4 | 66.8 | 20.8 | 10.2 | 20.8 | 3.21 | 47.5 | 23.8 | 47.5 | 34.9 |
| 21 | 64.9 | 32.4 | 64.9 | 20.8 | 10.2 | 20.8 | 3.12 | 45.6 | 22.8 | 45.6 | 34.9 |
| 20 | 63.1 | 31.5 | 63.1 | 20.8 | 10.2 | 20.8 | 3.03 | 43.8 | 21.9 | 43.8 | 34.9 |
| 19 | 61.3 | 30.6 | 61.3 | 20.8 | 10.2 | 20.8 | 2.95 | 42.0 | 21.0 | 42.0 | 34.9 |
| 18 | 59.6 | 29.8 | 59.6 | 20.8 | 10.2 | 20.8 | 2.87 | 40.3 | 20.1 | 40.3 | 34.9 |
| 17 | 57.9 | 28.9 | 57.9 | 20.8 | 10.2 | 20.8 | 2.78 | 38.6 | 19.3 | 38.6 | 34.9 |
| 16 | 56.3 | 28.1 | 56.3 | 20.8 | 10.2 | 20.8 | 2.71 | 37.0 | 18.5 | 37.0 | 35.0 |
| 15 | 54.7 | 27.3 | 54.7 | 20.8 | 10.2 | 20.8 | 2.63 | 35.4 | 17.7 | 35.4 | 35.0 |
| 14 | 53.2 | 26.6 | 53.2 | 20.8 | 10.2 | 20.8 | 2.55 | 33.9 | 16.9 | 33.9 | 35.0 |
| 13 | 51.7 | 25.8 | 51.7 | 20.8 | 10.2 | 20.8 | 2.48 | 32.4 | 16.2 | 32.4 | 35.0 |
| 12 | 50.2 | 25.1 | 50.2 | 20.8 | 10.2 | 20.8 | 2.41 | 30.9 | 15.5 | 30.9 | 35.0 |
| 11 | 48.8 | 24.4 | 48.8 | 20.8 | 10.2 | 20.8 | 2.35 | 29.5 | 14.8 | 29.5 | 35.0 |
| 10 | 47.5 | 23.7 | 47.5 | 20.8 | 10.2 | 20.8 | 2.28 | 28.2 | 14.1 | 28.2 | 35.0 |
| 9 | | | | | | | | | | | |
| 8 | | | | | | | | | | | |
| 7 | | | | | | | | | | | |
| 6 | | | | | | | | | | | |
| 5 | | | | | | | | | | | |

-- attention: operating limits not reflected in performance table

WAMAK TWW 110 WHR HeavyDuty 2L1

| Th -OU | 80 | | | | | | | | | | |
|-----------|--------------|-----------|-----------|-------------|------------|------------|-------------|-----------|-----------|-----------|----------|
| [°C] | Qh nom | Qh min | Qh max | Pin nom | Pin min | Pin max | COP nom | Qc nom | Qc min | Qc max | I nom |
| [°C] | [kW] | [kW] | [kW] | [kW] | [kW] | [kW] | kW / kW | [kW] | [kW] | [kW] | [A] |
| 45 | 113.2 | 56.6 | 113.2 | 25.3 | 12.4 | 25.3 | 4.47 | 89.7 | 44.9 | 89.7 | 41.0 |
| 44 | 110.1 | 55.1 | 110.1 | 25.3 | 12.4 | 25.3 | 4.35 | 86.6 | 43.3 | 86.6 | 41.0 |
| 43 | 107.1 | 53.5 | 107.1 | 25.3 | 12.4 | 25.3 | 4.23 | 83.6 | 41.8 | 83.6 | 41.0 |
| 42 | 104.2 | 52.1 | 104.2 | 25.3 | 12.5 | 25.3 | 4.11 | 80.7 | 40.3 | 80.7 | 41.0 |
| 41 | 101.3 | 50.7 | 101.3 | 25.3 | 12.5 | 25.3 | 4.00 | 77.8 | 38.9 | 77.8 | 41.0 |
| 40 | 98.5 | 49.3 | 98.5 | 25.4 | 12.5 | 25.4 | 3.89 | 75.0 | 37.5 | 75.0 | 41.0 |
| 39 | 95.8 | 47.9 | 95.8 | 25.4 | 12.5 | 25.4 | 3.78 | 72.3 | 36.2 | 72.3 | 41.1 |
| 38 | 93.2 | 46.6 | 93.2 | 25.4 | 12.5 | 25.4 | 3.67 | 69.7 | 34.8 | 69.7 | 41.1 |
| 37 | 90.6 | 45.3 | 90.6 | 25.4 | 12.5 | 25.4 | 3.57 | 67.1 | 33.6 | 67.1 | 41.1 |
| 36 | 88.2 | 44.1 | 88.2 | 25.4 | 12.5 | 25.4 | 3.47 | 64.6 | 32.3 | 64.6 | 41.1 |
| 35 | 85.8 | 42.9 | 85.8 | 25.4 | 12.5 | 25.4 | 3.37 | 62.2 | 31.1 | 62.2 | 41.1 |
| 34 | 83.4 | 41.7 | 83.4 | 25.4 | 12.5 | 25.4 | 3.28 | 59.8 | 29.9 | 59.8 | 41.1 |
| 33 | 81.1 | 40.6 | 81.1 | 25.4 | 12.5 | 25.4 | 3.19 | 57.5 | 28.8 | 57.5 | 41.2 |
| 32 | 78.9 | 39.5 | 78.9 | 25.5 | 12.5 | 25.5 | 3.10 | 55.3 | 27.7 | 55.3 | 41.2 |
| 31 | 76.8 | 38.4 | 76.8 | 25.5 | 12.5 | 25.5 | 3.01 | 53.2 | 26.6 | 53.2 | 41.2 |
| 30 | 74.7 | 37.4 | 74.7 | 25.5 | 12.5 | 25.5 | 2.93 | 51.1 | 25.5 | 51.1 | 41.2 |
| 29 | 72.7 | 36.4 | 72.7 | 25.5 | 12.5 | 25.5 | 2.85 | 49.0 | 24.5 | 49.0 | 41.2 |
| 28 | 70.8 | 35.4 | 70.8 | 25.5 | 12.6 | 25.5 | 2.77 | 47.1 | 23.5 | 47.1 | 41.3 |
| 27 | 68.9 | 34.4 | 68.9 | 25.6 | 12.6 | 25.6 | 2.69 | 45.2 | 22.6 | 45.2 | 41.3 |
| 26 | 67.0 | 33.5 | 67.0 | 25.6 | 12.6 | 25.6 | 2.62 | 43.3 | 21.7 | 43.3 | 41.3 |
| 25 | 65.2 | 32.6 | 65.2 | 25.6 | 12.6 | 25.6 | 2.55 | 41.5 | 20.8 | 41.5 | 41.3 |
| 24 | 63.5 | 31.8 | 63.5 | 25.6 | 12.6 | 25.6 | 2.48 | 39.8 | 19.9 | 39.8 | 41.4 |
| 23 | 61.9 | 30.9 | 61.9 | 25.6 | 12.6 | 25.6 | 2.41 | 38.1 | 19.0 | 38.1 | 41.4 |
| 22 | 60.2 | 30.1 | 60.2 | 25.7 | 12.6 | 25.7 | 2.35 | 36.4 | 18.2 | 36.4 | 41.4 |
| 21 | 58.7 | 29.3 | 58.7 | 25.7 | 12.6 | 25.7 | 2.28 | 34.8 | 17.4 | 34.8 | 41.5 |
| 20 | 57.2 | 28.6 | 57.2 | 25.7 | 12.6 | 25.7 | 2.22 | 33.3 | 16.6 | 33.3 | 41.5 |
| 19 | | | | | | | | | | | |
| 18 | | | | | | | | | | | |
| 17 | | | | | | | | | | | |
| 16 | | | | | | | | | | | |
| 15 | | | | | | | | | | | |
| 14 | | | | | | | | | | | |
| 13 | | | | | | | | | | | |
| 12 | | | | | | | | | | | |
| 11 | | | | | | | | | | | |
| 10 | | | | | | | | | | | |
| 9 | | | | | | | | | | | |
| 8 | | | | | | | | | | | |
| 7 | | | | | | | | | | | |
| 6 | | | | | | | | | | | |
| 5 | | | | | | | | | | | |

-- attention: operating limits not reflected in performance table

WAMAK TWW 110 WHR HeavyDuty 2L1

| Tc -OU | | W 12 / 7 °C | | | | | | | | | | |
|-----------|-------------|-------------|-----------|-------------|------------|------------|-------------|-----------|-----------|-----------|----------|--|
| [°C] | Qc nom | Qc min | Qc max | Pin nom | Pin min | Pin max | EER | Qh nom | Qh min | Qh max | I nom | |
| [°C] | [kW] | [kW] | [kW] | [kW] | [kW] | [kW] | kW / kW | [kW] | [kW] | [kW] | [A] | |
| 40 | 27.6 | 13.8 | 27.6 | 13.3 | 6.5 | 13.3 | 2.08 | 39.9 | 20.0 | 39.9 | 25.7 | |
| 39 | 28.1 | 14.0 | 28.1 | 13.0 | 6.4 | 13.0 | 2.16 | 40.1 | 20.1 | 40.1 | 25.4 | |
| 38 | 28.6 | 14.3 | 28.6 | 12.7 | 6.3 | 12.7 | 2.24 | 40.4 | 20.2 | 40.4 | 25.1 | |
| 37 | 29.0 | 14.5 | 29.0 | 12.5 | 6.1 | 12.5 | 2.32 | 40.6 | 20.3 | 40.6 | 24.9 | |
| 36 | 29.5 | 14.7 | 29.5 | 12.2 | 6.0 | 12.2 | 2.41 | 40.8 | 20.4 | 40.8 | 24.6 | |
| 35 | 29.9 | 15.0 | 29.9 | 12.0 | 5.9 | 12.0 | 2.49 | 41.1 | 20.5 | 41.1 | 24.3 | |
| 34 | 30.4 | 15.2 | 30.4 | 11.8 | 5.8 | 11.8 | 2.58 | 41.3 | 20.7 | 41.3 | 24.1 | |
| 33 | 30.8 | 15.4 | 30.8 | 11.5 | 5.7 | 11.5 | 2.67 | 41.6 | 20.8 | 41.6 | 23.8 | |
| 32 | 31.3 | 15.6 | 31.3 | 11.3 | 5.6 | 11.3 | 2.76 | 41.8 | 20.9 | 41.8 | 23.6 | |
| 31 | 31.7 | 15.9 | 31.7 | 11.1 | 5.5 | 11.1 | 2.86 | 42.0 | 21.0 | 42.0 | 23.4 | |
| 30 | 32.2 | 16.1 | 32.2 | 10.9 | 5.4 | 10.9 | 2.95 | 42.3 | 21.1 | 42.3 | 23.2 | |
| 29 | 32.6 | 16.3 | 32.6 | 10.7 | 5.3 | 10.7 | 3.05 | 42.5 | 21.3 | 42.5 | 23.0 | |
| 28 | 33.0 | 16.5 | 33.0 | 10.5 | 5.2 | 10.5 | 3.15 | 42.8 | 21.4 | 42.8 | 22.8 | |
| 27 | 33.4 | 16.7 | 33.4 | 10.3 | 5.1 | 10.3 | 3.25 | 43.0 | 21.5 | 43.0 | 22.6 | |
| 26 | 33.9 | 16.9 | 33.9 | 10.1 | 5.0 | 10.1 | 3.35 | 43.2 | 21.6 | 43.2 | 22.4 | |
| 25 | 34.3 | 17.1 | 34.3 | 9.9 | 4.9 | 9.9 | 3.45 | 43.5 | 21.7 | 43.5 | 22.2 | |
| 24 | 34.7 | 17.3 | 34.7 | 9.8 | 4.8 | 9.8 | 3.56 | 43.7 | 21.9 | 43.7 | 22.0 | |
| 23 | 35.1 | 17.5 | 35.1 | 9.6 | 4.7 | 9.6 | 3.66 | 44.0 | 22.0 | 44.0 | 21.9 | |
| 22 | 35.5 | 17.7 | 35.5 | 9.4 | 4.6 | 9.4 | 3.77 | 44.2 | 22.1 | 44.2 | 21.7 | |
| 21 | 35.9 | 17.9 | 35.9 | 9.2 | 4.5 | 9.2 | 3.88 | 44.4 | 22.2 | 44.4 | 21.6 | |
| 20 | 36.3 | 18.1 | 36.3 | 9.1 | 4.5 | 9.1 | 4.00 | 44.7 | 22.3 | 44.7 | 21.4 | |

| Tc [°C] | | W 23 / 18 °C | | | | | | | | | | |
|---------|-------------|--------------|-----------|-------------|------------|------------|-------------|-----------|-----------|-----------|----------|--|
| 0 | Qc nom | Qc min | Qc max | Pin nom | Pin min | Pin max | EER | Qh nom | Qh min | Qh max | I nom | |
| [°C] | [kW] | [kW] | [kW] | [kW] | [kW] | [kW] | kW / kW | [kW] | [kW] | [kW] | [A] | |
| 40 | 42.9 | 21.4 | 42.9 | 13.3 | 6.5 | 13.3 | 3.23 | 55.3 | 27.6 | 51.4 | 25.9 | |
| 39 | 43.5 | 21.7 | 43.5 | 13.0 | 6.4 | 13.0 | 3.34 | 55.7 | 27.8 | 51.8 | 25.6 | |
| 38 | 44.1 | 22.1 | 44.1 | 12.7 | 6.3 | 12.7 | 3.46 | 56.1 | 28.0 | 52.2 | 25.3 | |
| 37 | 44.7 | 22.4 | 44.7 | 12.5 | 6.1 | 12.5 | 3.58 | 56.5 | 28.2 | 52.6 | 25.0 | |
| 36 | 45.4 | 22.7 | 45.4 | 12.2 | 6.0 | 12.2 | 3.70 | 56.9 | 28.4 | 53.0 | 24.8 | |
| 35 | 46.0 | 23.0 | 46.0 | 12.0 | 5.9 | 12.0 | 3.83 | 57.3 | 28.6 | 53.3 | 24.5 | |
| 34 | 46.6 | 23.3 | 46.6 | 11.8 | 5.8 | 11.8 | 3.95 | 57.6 | 28.8 | 53.7 | 24.3 | |
| 33 | 47.2 | 23.6 | 47.2 | 11.5 | 5.7 | 11.5 | 4.08 | 58.0 | 29.0 | 54.1 | 24.0 | |
| 32 | 47.7 | 23.9 | 47.7 | 11.3 | 5.6 | 11.3 | 4.22 | 58.4 | 29.2 | 54.5 | 23.8 | |
| 31 | 48.3 | 24.2 | 48.3 | 11.1 | 5.5 | 11.1 | 4.35 | 58.8 | 29.4 | 54.9 | 23.6 | |
| 30 | 48.9 | 24.5 | 48.9 | 10.9 | 5.4 | 10.9 | 4.49 | 59.2 | 29.6 | 55.3 | 23.4 | |
| 29 | 49.5 | 24.7 | 49.5 | 10.7 | 5.3 | 10.7 | 4.63 | 59.6 | 29.8 | 55.7 | 23.2 | |
| 28 | 50.0 | 25.0 | 50.0 | 10.5 | 5.2 | 10.5 | 4.77 | 60.0 | 30.0 | 56.1 | 23.0 | |
| 27 | 50.6 | 25.3 | 50.6 | 10.3 | 5.1 | 10.3 | 4.91 | 60.3 | 30.2 | 56.5 | 22.8 | |
| 26 | 51.2 | 25.6 | 51.2 | 10.1 | 5.0 | 10.1 | 5.06 | 60.7 | 30.4 | 56.9 | 22.6 | |
| 25 | 51.7 | 25.9 | 51.7 | 9.9 | 4.9 | 9.9 | 5.21 | 61.1 | 30.5 | 57.3 | 22.4 | |
| 24 | 52.2 | 26.1 | 52.2 | 9.8 | 4.8 | 9.8 | 5.36 | 61.5 | 30.7 | 57.6 | 22.2 | |
| 23 | 52.8 | 26.4 | 52.8 | 9.6 | 4.7 | 9.6 | 5.51 | 61.8 | 30.9 | 58.0 | 22.0 | |
| 22 | 53.3 | 26.7 | 53.3 | 9.4 | 4.6 | 9.4 | 5.67 | 62.2 | 31.1 | 58.4 | 21.9 | |
| 21 | 53.8 | 26.9 | 53.8 | 9.2 | 4.5 | 9.2 | 5.83 | 62.6 | 31.3 | 58.8 | 21.7 | |
| 20 | 54.3 | 27.2 | 54.3 | 9.1 | 4.5 | 9.1 | 5.99 | 62.9 | 31.5 | 59.2 | 21.6 | |

-- attention: operating limits not reflected in performance table

LEGEND:



Ts-IN: Temperature renewable source - inlet [°C]
Th-OU: Temperature heating - outlet (flow) [°C]
Tc-OU: Temperature cooling - outlet (flow) [°C]
Qh nom: Heating capacity nominal
Qh min: Heating capacity minimal
Qh max: Heating capacity maximal
Pin nom: Power input at nominal heating capacity
Pin min: Power input at minimal heating capacity
Pin max: Power input at maximal heating capacity
COP nom: coefficient of performance at nominal heating capacity
Qc nom: cooling / heat extraction capacity at nominal heating capacity
Qc min: cooling / heat extraction at minimal heating capacity
Qc max: cooling / heat extraction at maximal heating capacity
I nom: Current at nominal heating capacity
EER: energy efficiency ratio at nominal cooling capacity

Operating limits

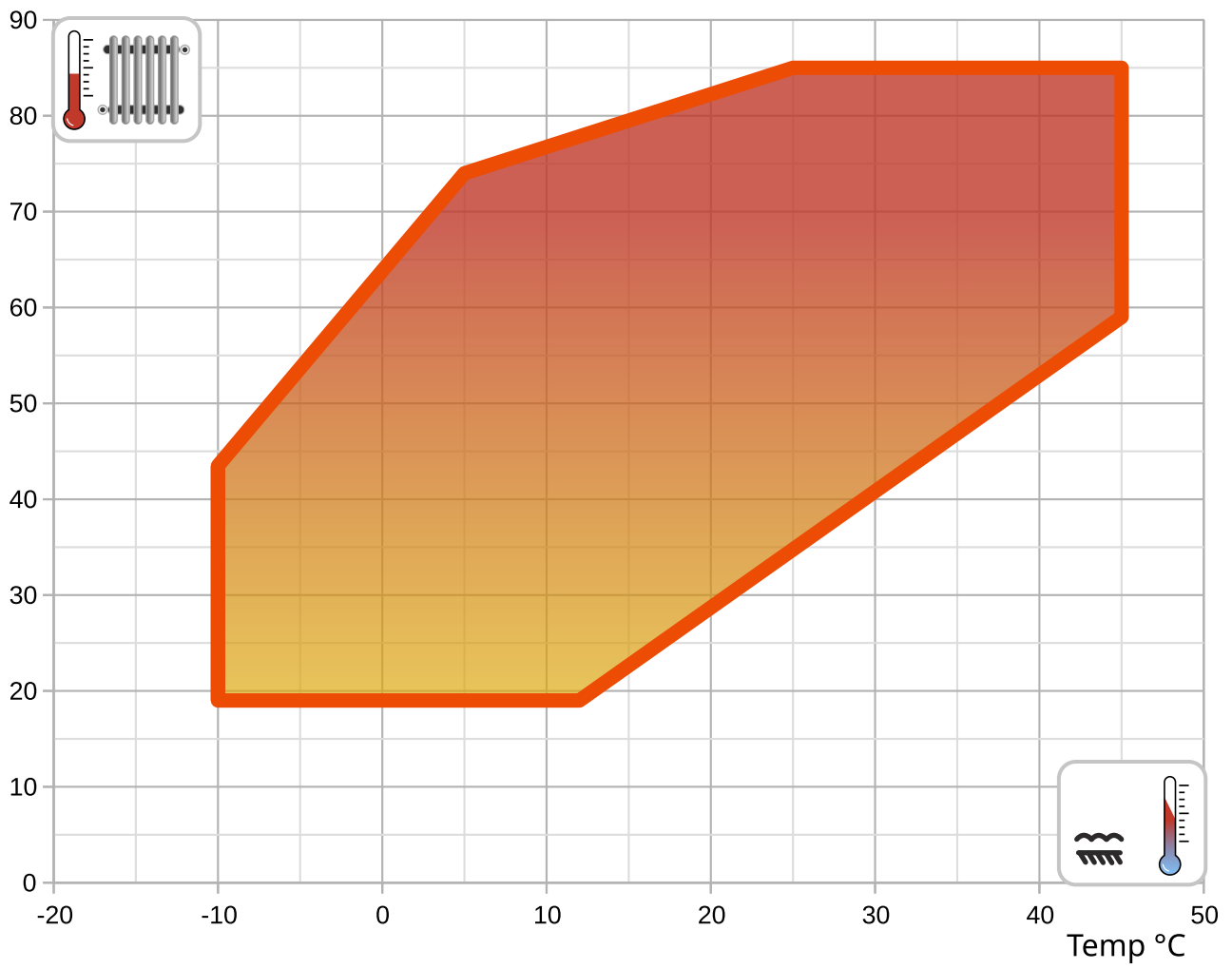
Temp °C

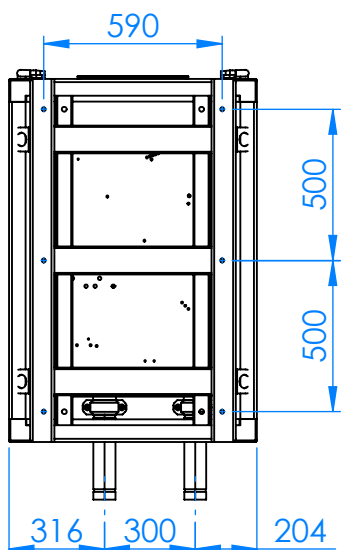
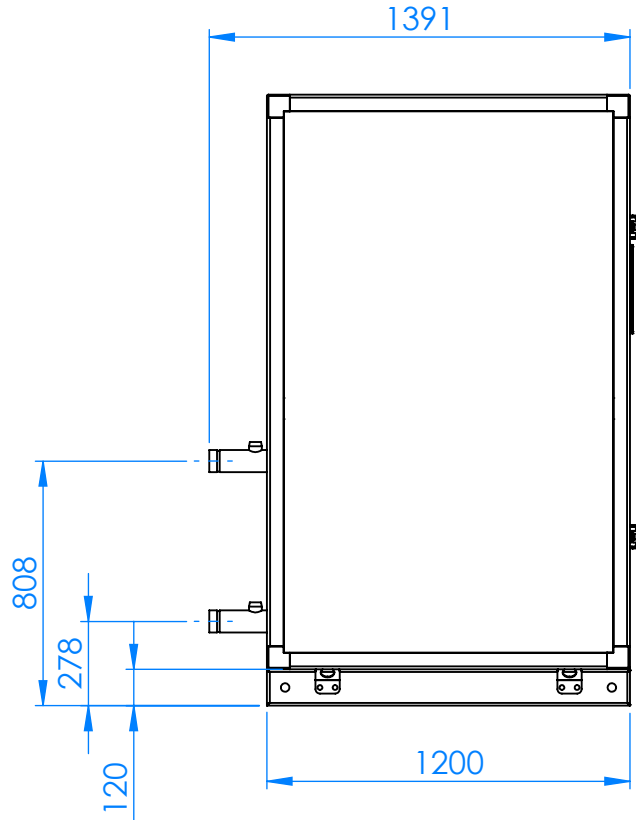
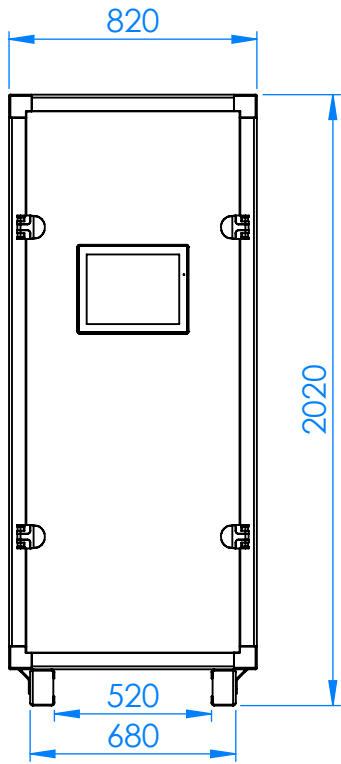

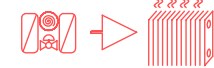
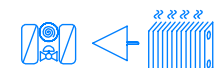
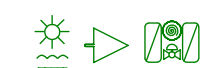

- A - 
- B - 
- D - 
- E - 

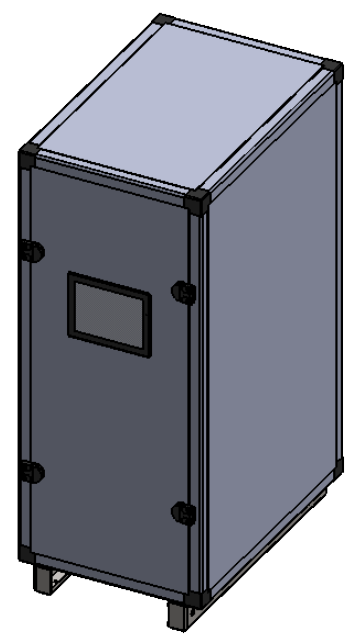
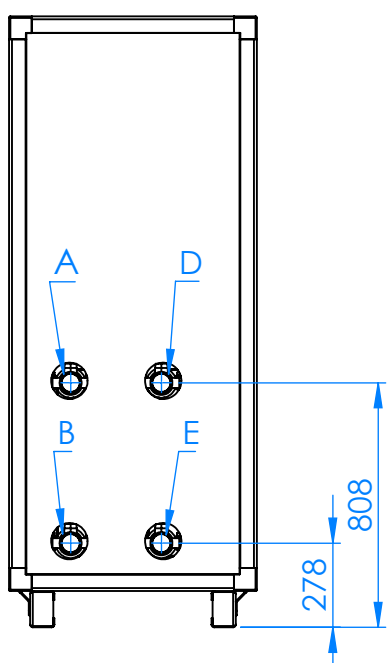

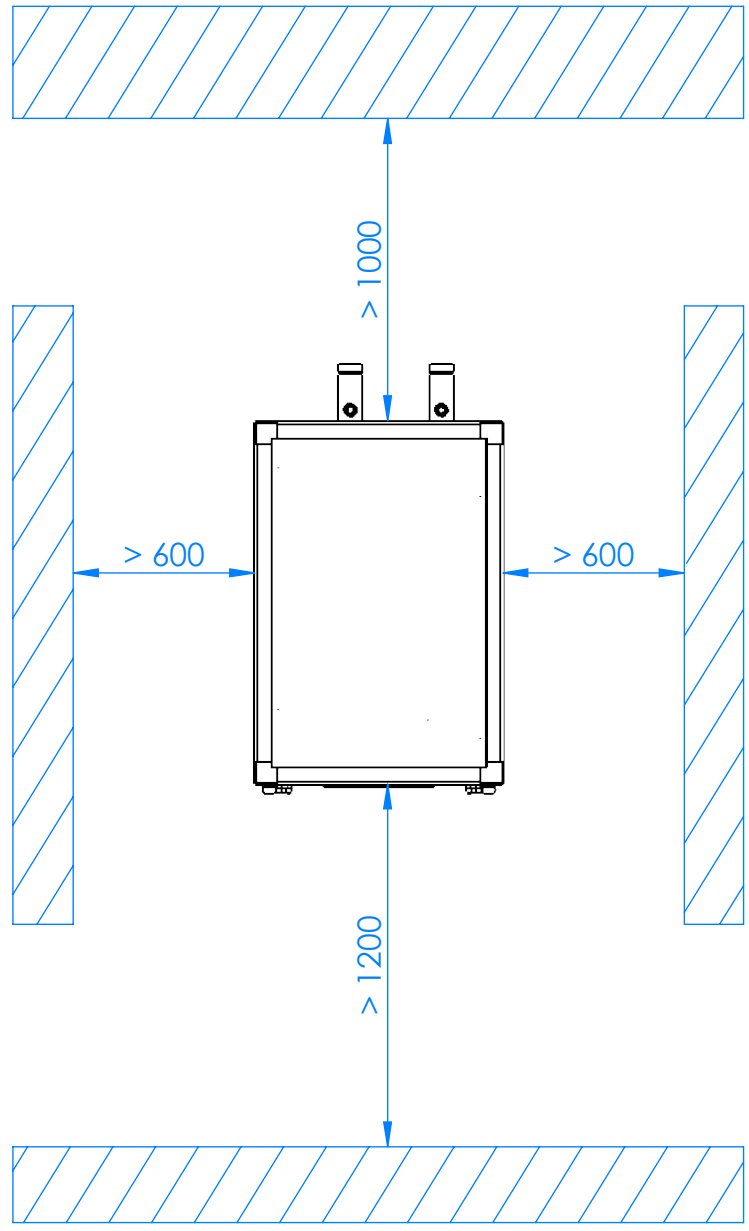

WAMAK TWW 110 WHR HeavyDuty 2L1

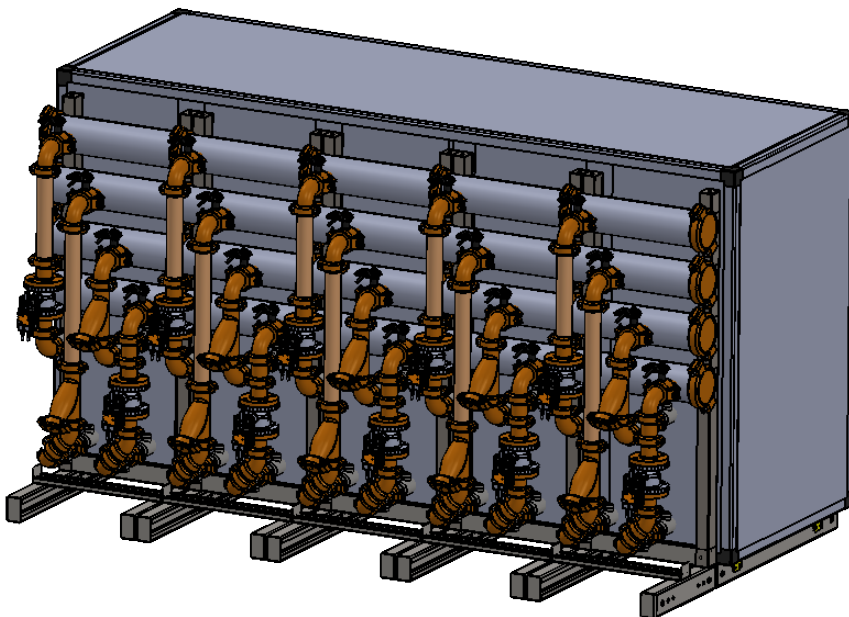
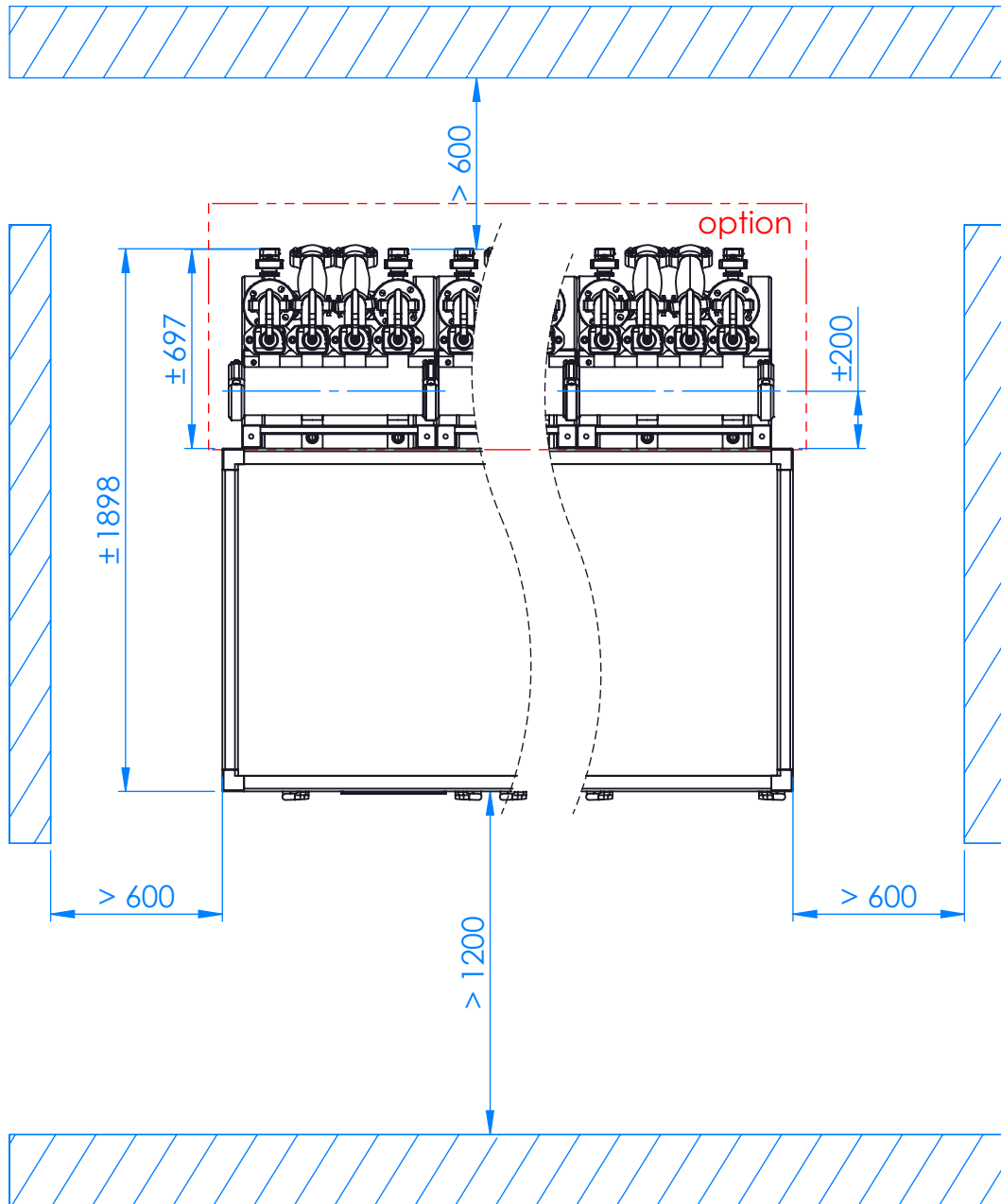

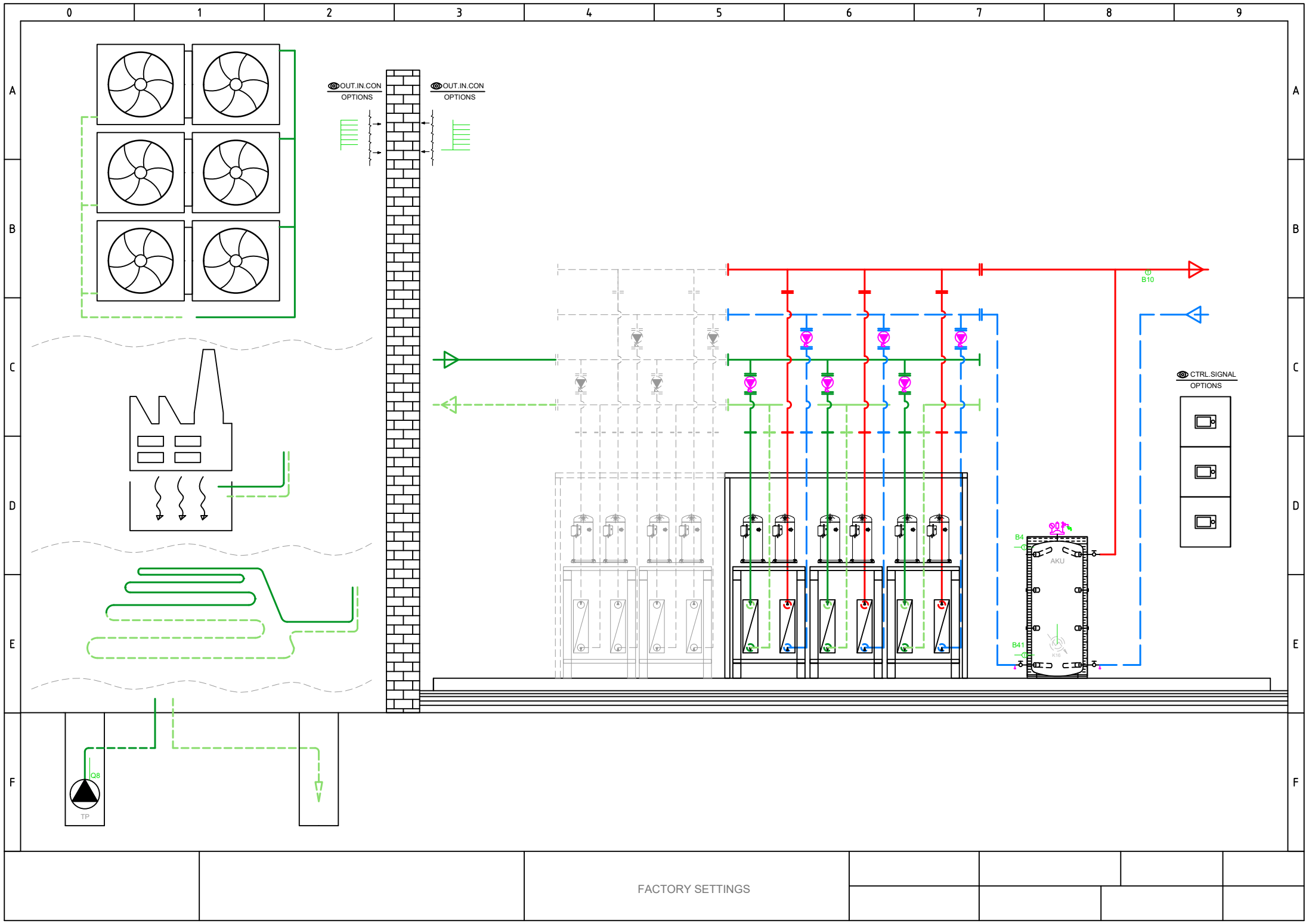

Total: max 6A
1 x QX...: max 2A

Main power supply 230V / 50 Hz
Ground
Neutral conductor

- E9 Low-pressure switch E9
- E10 High-pressure switch E10
- E15 Flow switch source E15
- E24 Flow switch consumers E24
- E6 Electrical utility lock E6
- E12 Overload compressor 2 E12
- E21 Mains supervision E21
- E22 Mains supervision E22
- E23 Mains supervision E23
- E11 Overload compressor 1 E11
- K1 Compressor stage 1 K1

Q8 Source pump Q8

Q9 Condenser pump Q9

K10 Alarm output K10

K40 Crankcase heater K40

K81 Valve evaporator K81

K82 Valve EVI K82

K2 Compressor stage 2 K2

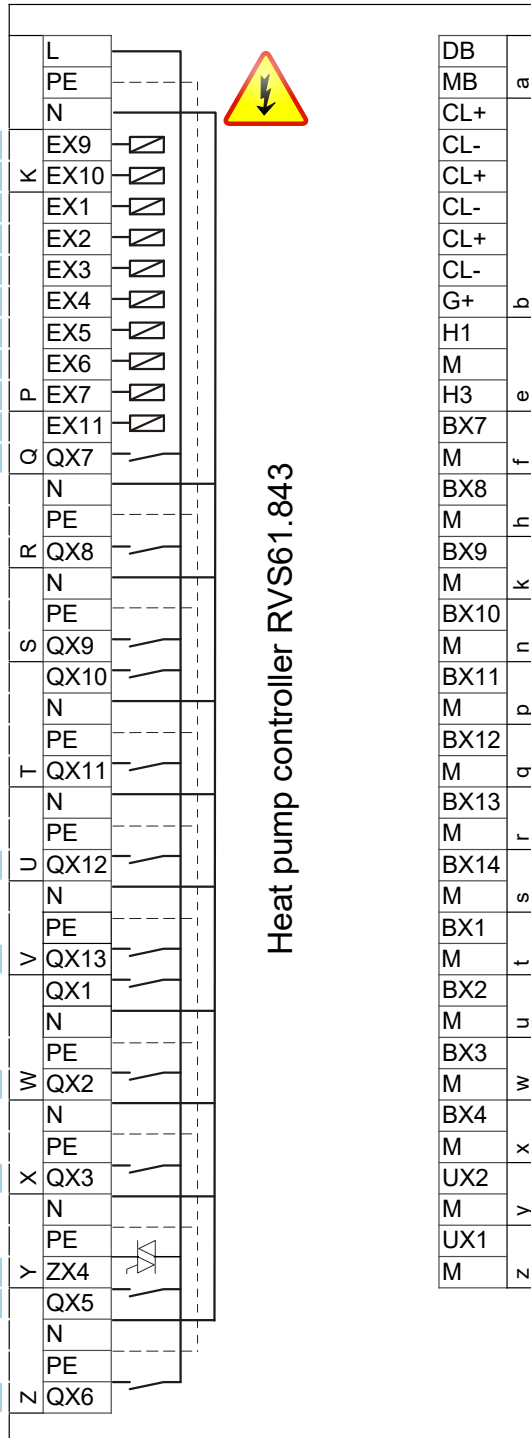

- DB LPB Bus data
- MB LPB Bus GND
- CL+ Room unit QAA...
- CL- Room unit QAA...
- CL+ Room unit QAA... 2.
- CL- Room unit QAA... 2.
- CL+ Room unit QAA... 3.
- CL- Room unit QAA... 3.
- G+ 12V supply → OUT
- H1
- M
- H3 Consumer request VK1
- BX7 B81 Hot-gas sensor K1 B81
- M
- BX8
- M
- BX9
- M
- BX10 B21 HP flow sensor B21
- M
- BX11
- M
- BX12 B71 HP return sensor B71
- M
- BX13 B91 Source inlet sensor B91
- M
- BX14 B84 Source outl sens B92/B84
- M
- BX1
- M
- BX2
- M
- BX3 B83 Refrig sensor liquid B83
- M
- BX4 B82 Hot-gas sensor K2 B82
- M
- UX2 Condenser pump Q9
- M
- UX1 0..10 V Signal
- M
- UX1 Source pump Q8
- M
- UX1 0..10 V Signal



- AVS75.390
- AVS75.391
- AVS75.370

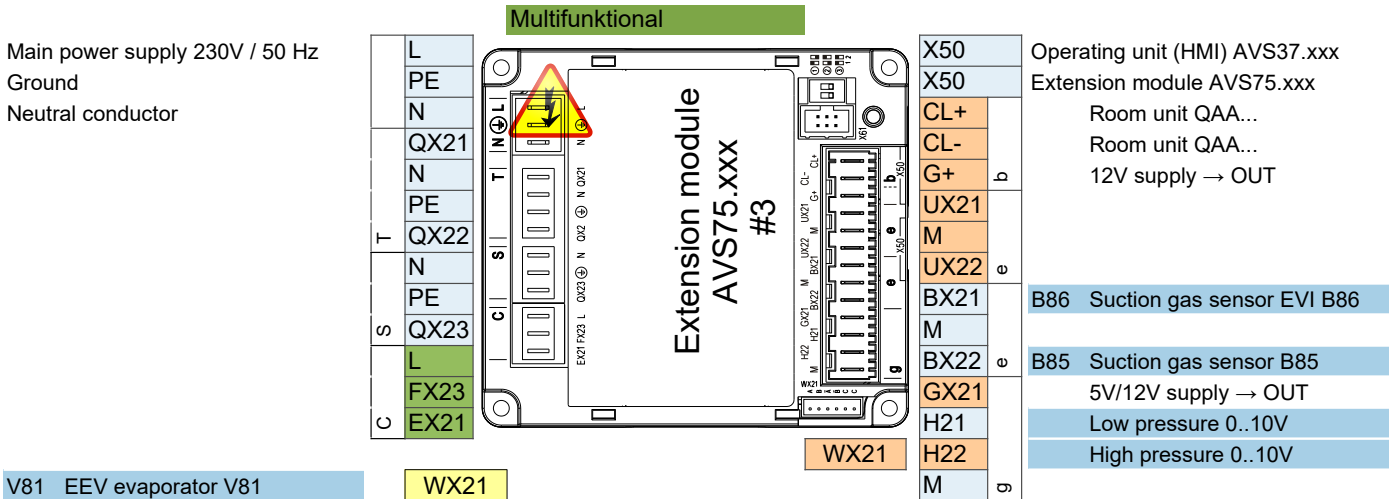
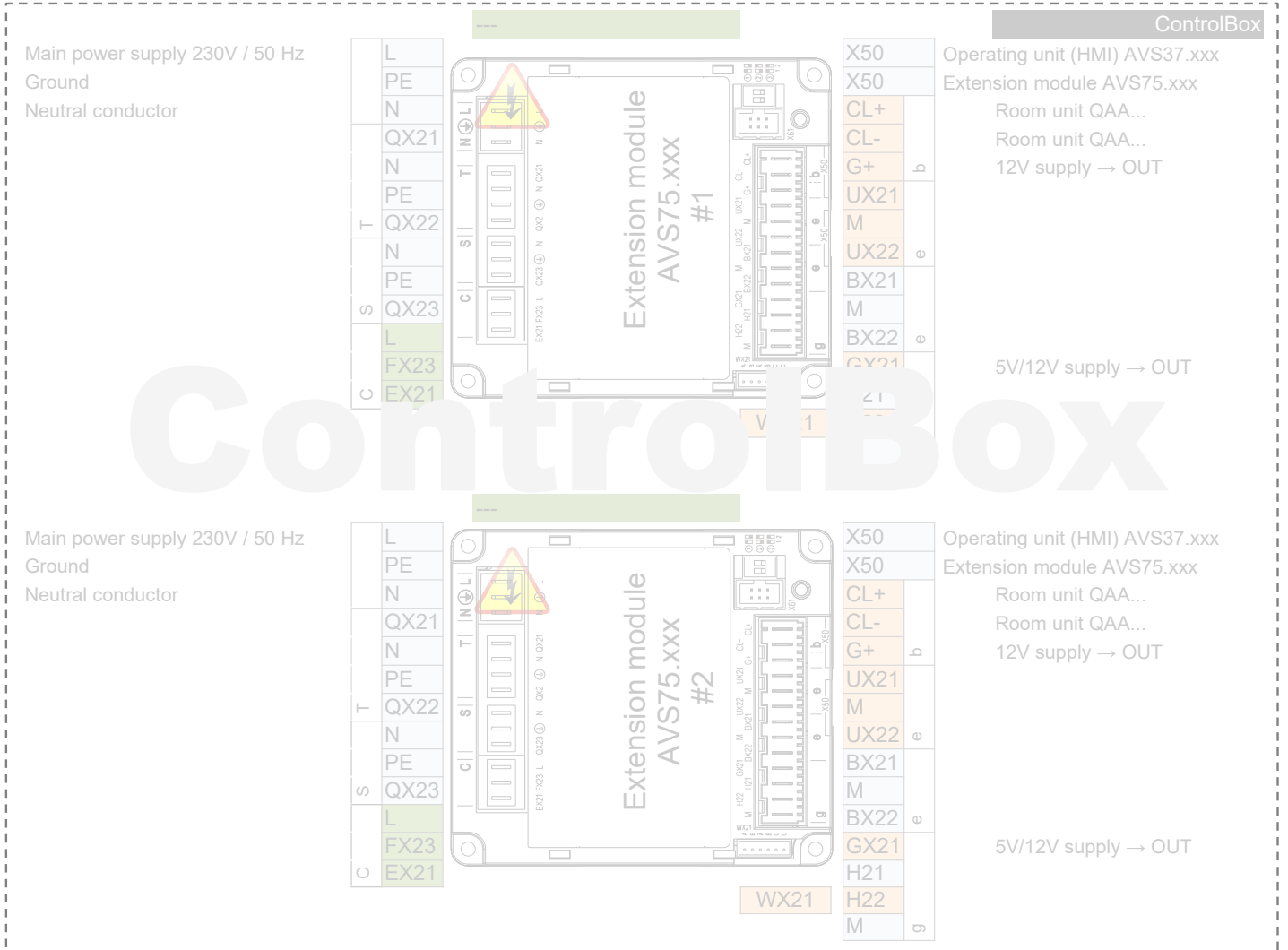

HEAT PUMP

EXTERNAL
INTERNAL

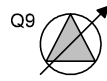
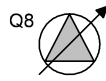

K1

K2

K82

K81

K40

K10

Q8 UX1

Q9 UX2

E11
KRW1
F1K
E11

E12
KRW2
F2K
E12

E6

Q9.ERR
F1S
E24

Q8.ERR
F1Z
E15

E10

E9

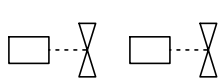

230V,50Hz
max 6A

0...10V



230V,50Hz
max 6A

0...10V

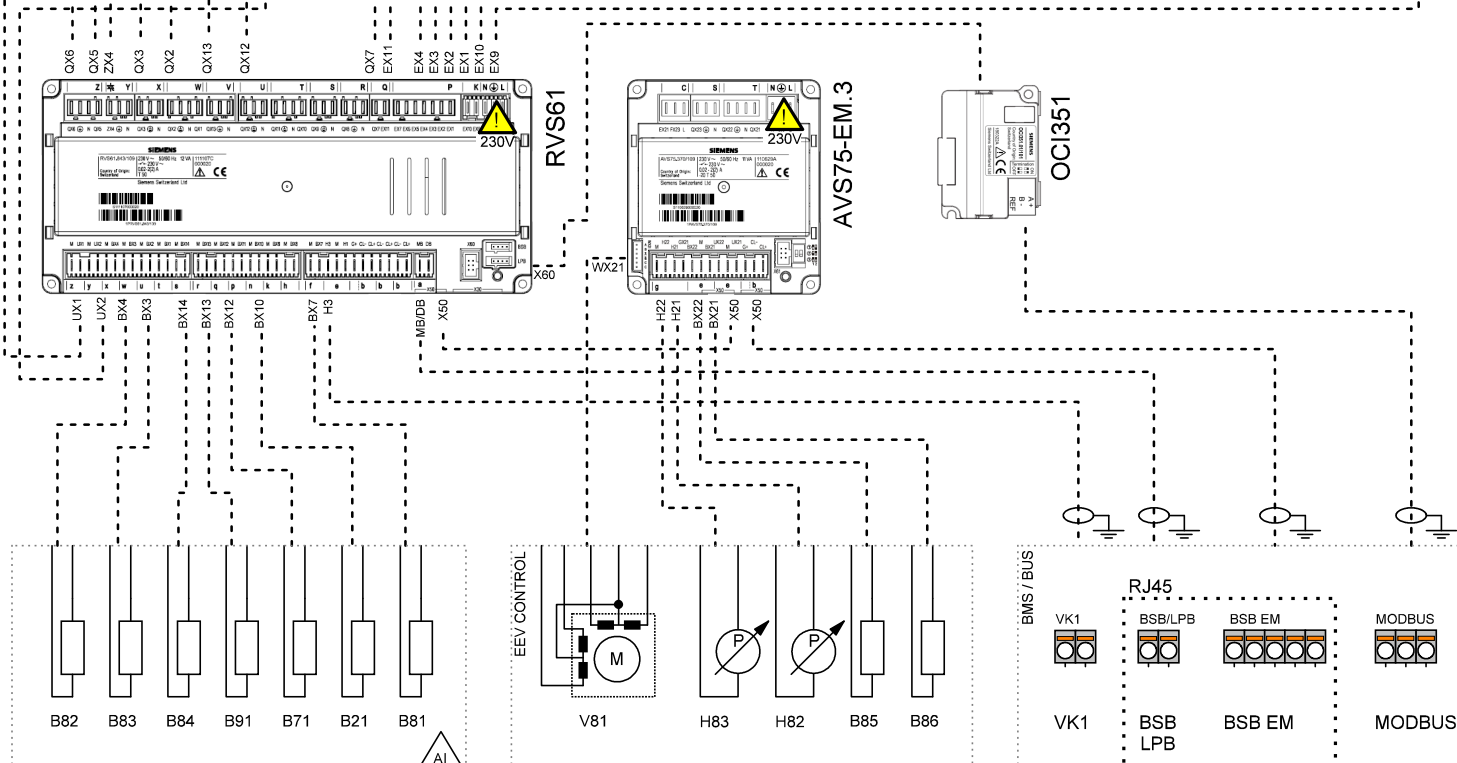
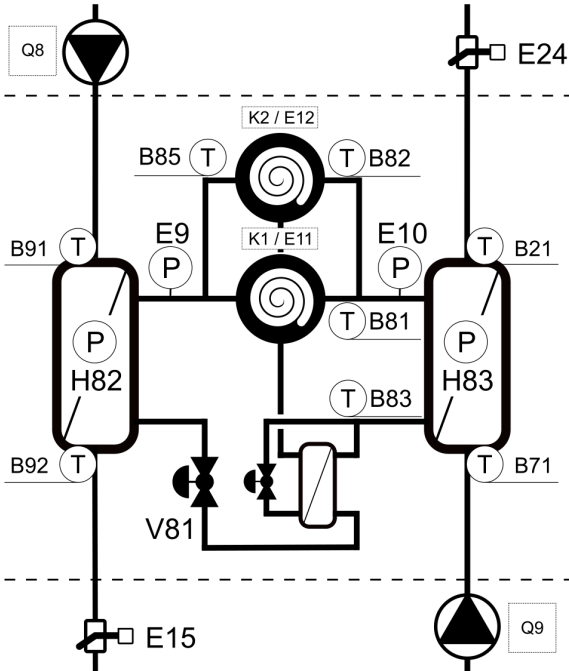

PWR SPLY: 3~ 400V, 50 Hz
CTRL: 1~ 230V, 50 HZ

| | | | | | | |
|---------|---------|----------------|--------|------------|------|------|
| Company | Title | Version / Note | Number | Created by | Date | Page |
| | TBW-TWW | 05/2024 | | | | 1 |

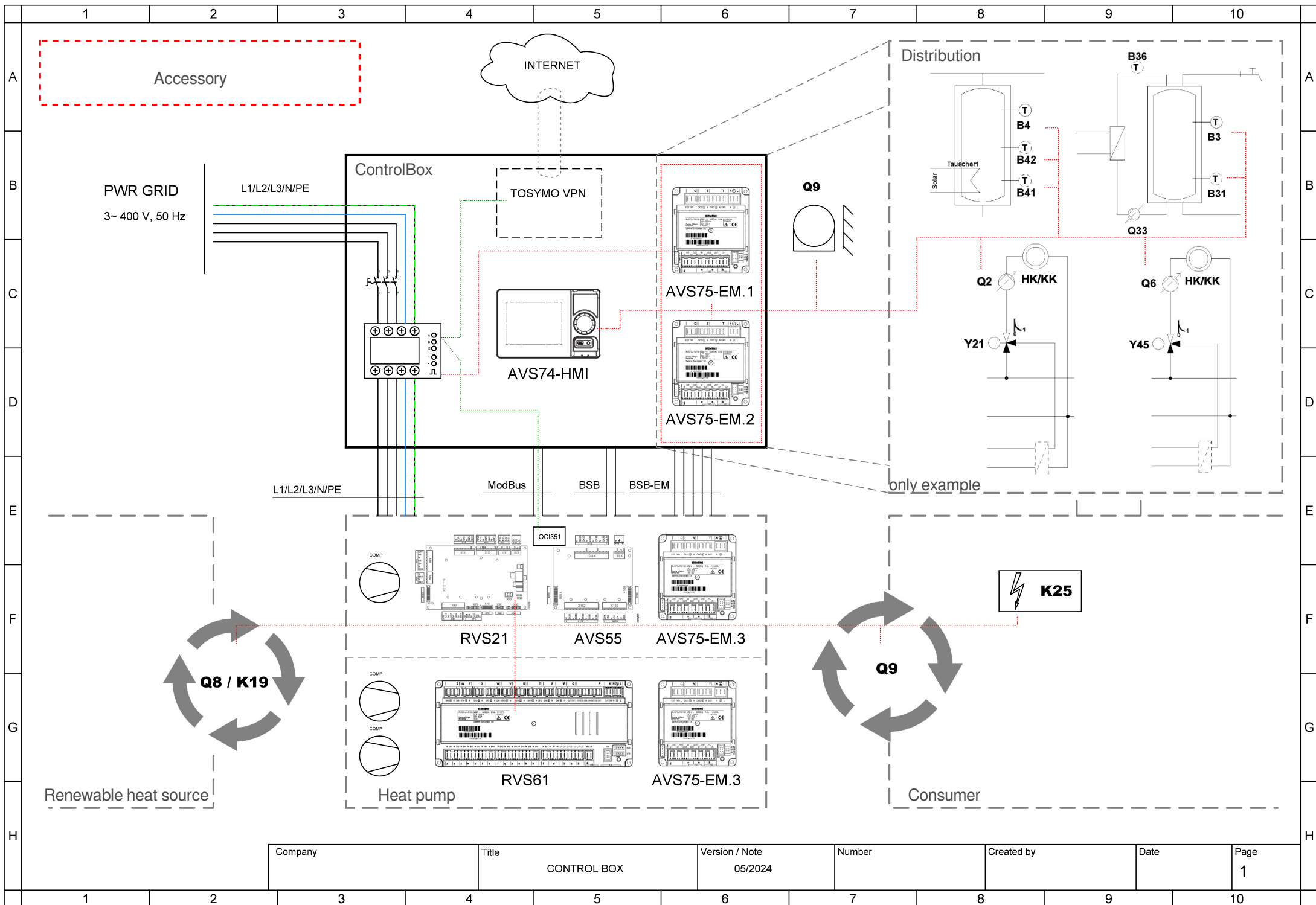

| | | | | | | |
|---------|-------------|----------------|--------|------------|------|------|
| Company | Title | Version / Note | Number | Created by | Date | Page |
| | CONTROL BOX | 05/2024 | | | | 1 |



| | | | | | | |
|---------|-------------|----------------|--------|------------|------|------|
| Company | Title | Version / Note | Number | Created by | Date | Page |
| | CONTROL BOX | 05/2024 | | | | 2 |



| | | | | | | |
|---------|-------------|----------------|--------|------------|------|------|
| Company | Title | Version / Note | Number | Created by | Date | Page |
| | CONTROL BOX | 05/2024 | | | | 3 |



| | | | | | | |
|---------|-------------|----------------|--------|------------|------|------|
| Company | Title | Version / Note | Number | Created by | Date | Page |
| | CONTROL BOX | 05/2024 | | | | 4 |

- AVS75.390
- AVS75.391
- AVS75.370

- AVS75.370**
 Main power supply 230V / 50 Hz
 Ground
 Neutral conductor
Y1 Mixing valve Open

Y2 Mixing valve Close

Q2 Heat circuit pump HC1 Q2

L Phase 230V
E61 Smart grid E61

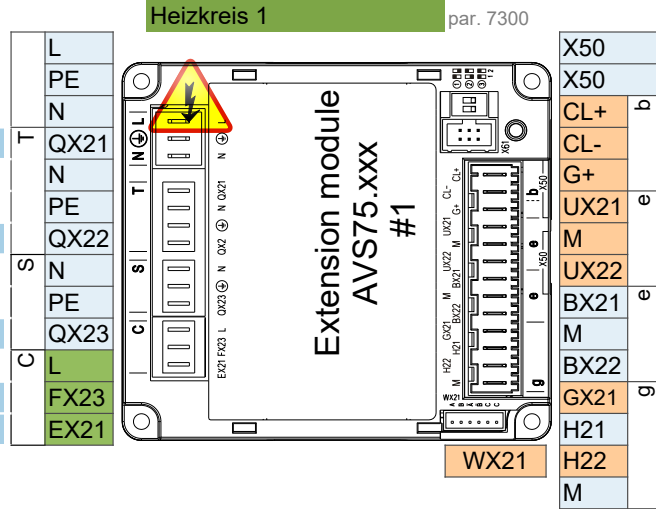

- Extension module AVS75.xxx
 Room unit QAA...
 Room unit QAA...

B1 Flow sensor 1

 Pulse count

- AVS75.370**
 Main power supply 230V / 50 Hz
 Ground
 Neutral conductor
Q3 DHW ctrl elem Q3

K6 El imm heater DHW K6

Q6 Heat circuit pump HC2 Q6

L Phase 230V
E62 Smart grid E62

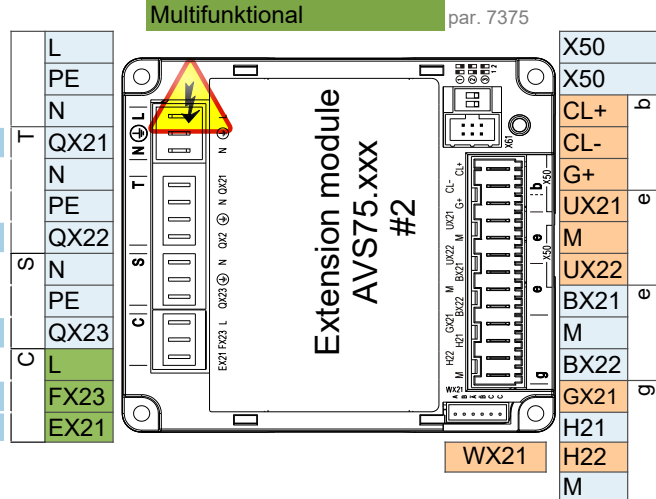

- Operating unit (HMI) AVS37.xxx
 Extension module AVS75.xxx
 Room unit QAA...
 Room unit QAA...

B3 DHW sensor B3

B4 Buffer sensor B4

- Main power supply 230V / 50 Hz
 Ground
 Neutral conductor

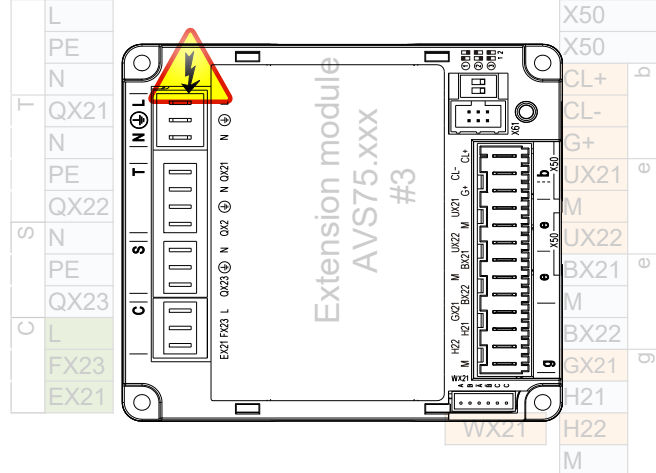

- Operating unit (HMI) AVS37.xxx
 Extension module AVS75.xxx
 Room unit QAA...
 Room unit QAA...

Attention: Extension module 3 is inside the heat pump

Control connection options

1 ControlBox

ControlBox, with two built-in extension modules, enables numerous options for application control on the consumer side behind the heat pump. For more, see the ControlBox schematic and the application diagrams sheet.

2 Fix flow temperature setpoint - On / Off dry (potential free) contact

2 wire shielded cable 2 x 0.5 mm² - Setpoint = 45°C (editable by param. 1859)

Connection terminal - see wiring diagram

3 Analog 0..10V flow temperature setpoint control

2 wire shielded cable 2 x 0.5 mm² - Setpoint: 0V = 16°C ~ 10V = 60°C (editable in parameter set)

Connection terminal - see wiring diagram

4 ModBus RTU communication command

3 wire shielded cable min. 3 x 0.25mm²

For ModBus mapping table contact technical support

5 MQTT IoT communication protocol

For more information contact technical support