

Basic performance data - WAMAK TWW 550 WHR HeavyDuty 2L5

Heating - EN 14511		
Heating capacity [kW]	W10 / W35 (max)	303.6 (30.4 / 303.6)
	W10 / W35 (min)	30.4 (30.4 / 303.6)
	W10 / W34	305.4 (30.5 / 305.4)
Electrical power input [kW]	W10 / W35 (max)	51.5 (5.0 / 51.5)
	W10 / W35 (min)	5.0 (5.0 / 51.5)
	W10 / W34	50.6 (4.9 / 50.6)
Heating efficiency faktor [COP]	W10 / W35 (max)	5.89
	W10 / W35 (min)	6.08
	W10 / W34	6.04
Seasonal space heating energy efficiency - SCOP EN 14825		
Average Climate / Low Temperature [35°C]	SCOP	6.79
	η [%]	271.8
	Label	A+++
	Qhe [kWh]	91963.1
	Pdesignh [kW]	303.6
	Tbivalent [°C]	-7
Cooling		
Cooling capacity - [kW]	A35 / W23-18	229.8
	A25 / W23-18	258.5
	A35 / W12-7	149.7
	A25 / W12-7	149.7
Seasonal space cooling energy efficiency - SEER EN 14825		
[W 23 / 18°C]	SEER	5.44
	Qce [kWh]	89820.0
	η_c [%]	217.6
Sound EN 12102		
Acoustic power - Lw	dB(A)	75.1
Acoustic pressure - Lp	1 m dB(A)	67.1
	5 m dB(A)	53.1
	10 m dB(A)	47.1
Mechanical and operational information		
Compressor type (3~ 400/50)	SCROLL / 10 /	On/Off
Refrigerant	R513A (GWP - 631)	5 x 11.2 kg
Operating limit temperatures heating - (min / max) [°C]		45 / 85
Operating limit temperatures source - (min / max) [°C]		-10 / 50
Weight		3100 kg

Main technical data - WAMAK TWW 550 WHR HeavyDuty 2L5

Enclosure type		HD2L5		Heat energy rejection side data			
Basic dimensions	Height [mm]	2000		Operating limit temperatures heating	MAX [°C]	85	
	Width [mm]	3450			MIN [°C]	45	
	Length [mm]	1200		for more see operating limits diagram			
Weight [kg]	3100		Condenser	Port size	5 x VIC 2.1/2 "		
Colour	Gray			Type	BPHE		
Enclosure IP Class	IP20			Count	5		
				Material	AISI 316		
Refrigeration cycle			Maximal operating pressure - refrigerant [bar]				32
Compressor	Type	Scroll		Maximal operating pressure - Water [bar]			6
	Number of stages	10		Testing pressure [bar]			70
	On/Off			Heat transfer medium			Water
	Power factor Cosφ	0.63		Volume flow @ dT 5K (nom) - Water [m3/h]			7.27 ~ 72.66
	Winding resistance	1.23 Ohm		Internal pressure drop - Water [kPa]			5 x 20
Refrigerant		R513A		Temperature difference @ 35°C (nom)			5 K
	Volme	5 x 11.2 kg		@ 55°C			8 K
	GWP	631		@ 65°C			10 K
	Safety class	A1					
Refrigeration oil type	POE RL32-3MAF		Renewable energy extraction side data				
	Oil volume	10 x 3.25 L		Operating limit temperatures source	MIN [°C]	-10	
Maximal pressure - refrigerant [bar]	32		for more see operating limits diagram				
	PED class	2		Evaporator	MAX [°C]	50	
EVI - vapour injection with economizer			Port size		5 x VIC 2.1/2 "		
Electrical connection data			Type		BPHE		
Line voltage [#~ V/Hz]	3~ 400/50		Count	5			
Current	nominal [A]	172.20		Material	AISI 316		
	maximal [A]	223.00		Maximal operating pressure - refrigerant [bar]			20
	starting [A]	12.9		Heat transfer medium			Water
Softstart	-		Maximal operating pressure - Water [bar]			6	
Main safety	C240		Volume flow - Water [m3/h]			6.84 ~ 68.41	
Control System			Internal pressure drop - Water [kPa]			5 x 20	
Main controller	SIEMENS	RVS 61		Temperature difference - Water			4 K
Extension module	AVS75.3xx	AVS75.3xx	AVS75.372				
Bus Clip-In			Modbus OCI352				
Online connection	Web server OZW672		ToSyMo				
Superheat controller			SEC61				

*** with accessory

WAMAK TWW 550 WHR HeavyDuty 2L5

ErP (EU) No 811/2013: Technical parameters for heat pump space heaters

Model	TWW 550 WHR HeavyDuty 2L5
Air-to-water heat pump	no
Brine-to-water heat pump	no
Water-to-water heat pump	yes
Low-temperature heat pump	no
Equipped with a supplementary heater	no
Heat pump combination heater	no
Temperature application	low (35°C - 30°C)
Climate conditions	average

Item	Symbol	Value	Unit	Item	Symbol	Value	Unit
Rated heat output at Tdesignh	Prated	303.6	kW	Seasonal space heating energy efficiency	η_s	271.8	%
Declared capacity for heating for part load at indoor temperature 20 °C and outdoor temperature Tj				Declared coefficient of performance or primary energy ratio for part load at indoor temperature 20 °C and outdoor temperature Tj			
Tj = -7 °C	Pdh	305.4	kW	Tj = -7 °C	COPd	6.04	-
Tj = +2 °C	Pdh	312.8	kW	Tj = +2 °C	COPd	6.6	-
Tj = +7 °C	Pdh	318.1	kW	Tj = +7 °C	COPd	7.4	-
Tj = +12 °C	Pdh	323.2	kW	Tj = +12 °C	COPd	7.9	-
Tj = bivalent temperature	Pdh	303.6	kW	Tj = bivalent temperature	COPd	5.9	-
Tj = operation limit temperature	Pdh	---	kW	Tj = operation limit temperature	COPd	---	-
Bivalent temperature	Tbiv	-7	°C	Tj = operation limit temperature	TOL	---	°C
Power consumption in modes other than active mode				Heating water operating limit temperature	WTOL	85	°C
Off mode	Poff	0.040	kW	Supplementary heater			
Thermostat-off mode	Pto	0.010	kW	Rated heat output	Psup	57.6	kW
Standby mode	Psb	0.010	kW	Type of energy input	electricity		
Crankcase heater mode	Pck	0.050	kW				
Other items				For air-to-water heat pumps: Rated air flow rate, outdoors	-	---	m ³ /h
Capacity control	multi-stage			For water- or brine-to-water heat pumps: Rated brine or water flow rate, outdoor heat exchanger	-	6.84 ~ 68.41	m ³ /h
Sound power level							
indoors	Lwa	75	dB				
outdoors	Lwa	---	dB				
Annual energy consumption	Q _{HE}	91963.1	kWh				

Contact details: WAMAK, s.r.o., Orovnicna 252, 96652, Orovnicna, Slovakia, info@wamak.sk

WAMAK TWW 550 WHR HeavyDuty 2L5

ErP (EU) No 811/2013: Technical parameters for heat pump space heaters

Model	TWW 550 WHR HeavyDuty 2L5
Air-to-water heat pump	no
Brine-to-water heat pump	no
Water-to-water heat pump	yes
Low-temperature heat pump	no
Equipped with a supplementary heater	no
Heat pump combination heater	no
Temperature application	middle (55°C - 47°C)
Climate conditions	average

Item	Symbol	Value	Unit	Item	Symbol	Value	Unit
Rated heat output at Tdesignh	Prated	264.8	kW	Seasonal space heating energy efficiency	η_s	204.5	%
Declared capacity for heating for part load at indoor temperature 20 °C and outdoor temperature Tj				Declared coefficient of performance or primary energy ratio for part load at indoor temperature 20 °C and outdoor temperature Tj			
Tj = -7 °C	Pdh	277.0	kW	Tj = -7 °C	COPd	3.97	-
Tj = +2 °C	Pdh	299.0	kW	Tj = +2 °C	COPd	5.3	-
Tj = +7 °C	Pdh	309.7	kW	Tj = +7 °C	COPd	6.3	-
Tj = +12 °C	Pdh	318.1	kW	Tj = +12 °C	COPd	7.0	-
Tj = bivalent temperature	Pdh	264.8	kW	Tj = bivalent temperature	COPd	3.5	-
Tj = operation limit temperature	Pdh	---	kW	Tj = operation limit temperature	COPd	---	-
Bivalent temperature	Tbiv	-7	°C	Tj = operation limit temperature	TOL	---	°C
Power consumption in modes other than active mode				Heating water operating limit temperature	WTOL	85	°C
Off mode	Poff	0.040	kW	Supplementary heater			
Thermostat-off mode	Pto	0.010	kW	Rated heat output	Psup	57.6	kW
Standby mode	Psb	0.010	kW	Type of energy input	electricity		
Crankcase heater mode	Pck	0.050	kW	For air-to-water heat pumps:			
Other items				Rated air flow rate, outdoors	-	---	m ³ /h
Capacity control	multi-stage			For water- or brine-to-water heat pumps: Rated brine or water flow rate, outdoor heat exchanger			
Sound power level							
indoors	Lwa	75	dB				
outdoors	Lwa	---	dB				
Annual energy consumption	Q _{HE}	106635.6	kWh				

Contact details: WAMAK, s.r.o., Orovnic 252, 96652, Orovnic, Slovakia, info@wamak.sk



ENERG Y IIA
 енергия - ενεργεια IE IA



TWW 550 WHR
 HeavyDuty 2L5



55 °C

35 °C



A+++

A+++



75 dB



--- dB

■ 279	■ 310
■ 265	■ 304
■ 260	■ 289
kW	kW



2019

811/2013

TWW 550 WHR
 HeavyDuty 2L5

ErP Data

	55 °C	35 °C
Energy class	A+++	A+++
η [%]	204.5	271.8
P_{rated} [kW]	265	304
Q_{HE} [kWh/y]	106636	91964
SCOP [-]	5.11	6.79
$T_{bivalent}$ [°C]	-7	-7

CONTROLLER



+ QAA55/75	class VII	3.5% ↓
- QAA55/75	class III	1.5% ↓

Heating performance data		Heat recovery		
Operating conditions		Qh	P	COP
W45 / W80		566.0	126.5	4.47
W30 / W70		420.6	104.1	4.04
W25 / W60		467.9	85.8	5.45

Normative data: water - water application

Source - Water [10°C] / Low Temperature [35°C]

Operating conditions		Qh	P	COP
1	W10 / W30-35	303.6	51.5	5.89
2	W10 / W30-35 (MIN)	30.4	5.0	6.08
A	W10 / Wxx-34	305.4	50.6	6.04
B	W10 / Wxx-30	312.8	47.1	6.65
C	W10 / Wxx-27	318.1	44.6	7.36
D	W10 / Wxx-24	323.2	42.2	7.90
E	W10 / Wxx-35	303.6	51.5	5.89
F	W10 / Wxx-35	303.6	51.5	5.89

SCOP DATA EN 14825:2018	
Source - Water [10°C] / Low Temperature [35°C]	
SCOPon	6.82
SCOPnet	6.82
SCOP	6.79
η [%]	271.76
Label	A+++
Qh [kWh]	91963
Pdesignh [kW]	303.6
Tbivalent [°C]	-7.00

Source - Water [10°C] / Medium Temperature [55°C]

Operating conditions		Qh	P	COP
1	W10 / W47-55	264.8	75.7	3.50
2	W10 / W47-55 (MIN)	26.5	7.3	3.61
A	W10 / Wxx-52	277.0	69.8	3.97
B	W10 / Wxx-42	299.0	56.5	5.29
C	W10 / Wxx-36	309.7	51.1	6.25
D	W10 / Wxx-30	318.1	47.1	6.96
E	W10 / Wxx-55	264.8	75.7	3.50
F	W10 / Wxx-55	264.8	75.7	3.50

SCOP DATA EN 14825:2018	
Source - Water [10°C] / Medium Temperature [55°C]	
SCOPon	5.13
SCOPnet	5.13
SCOP	5.11
η [%]	204.52
Label	A+++
Qh [kWh]	106636
Pdesignh [kW]	264.8
Tbivalent [°C]	-7.00

Low temperature cooling W 12 / 7°C

Operating conditions					SEER DATA EN 14825:2018 [W 12 / 7°C]	
		Qc	P	EER		
A	W30-35 / W12-7	160.8	54.5	2.95	SEERon	3.64
B	W26-xx / W12-7	169.3	50.6	3.35	SEER	3.62
C	W22-xx / W12-7	177.4	47.0	3.77	Qc [kWh]	89820
D	W18-xx / W12-7	181.3	45.4	4.00	η [%]	144.91

Radiant cooling W 23 / 18°C

Operating conditions					SEER DATA EN 14825:2018 [W 23 / 18°C]	
		Qc	P	EER		
A	W50-xx / W23-18	180.9	82.0	2.21	SEERon	5.48
B	W40-xx / W23-18	214.3	66.4	3.23	SEER	5.44
C	W30-35 / W23-18	244.6	54.5	4.49	Qc [kWh]	89820
D	W26-xx / W23-18	255.8	50.6	5.06	η [%]	217.65

Performance lines - heating

- Qh-nom-35
- Qh-nom-55
- Qh-nom-60
- Qh-nom-70
- Qh-nom-80
- - - Qh-min-70

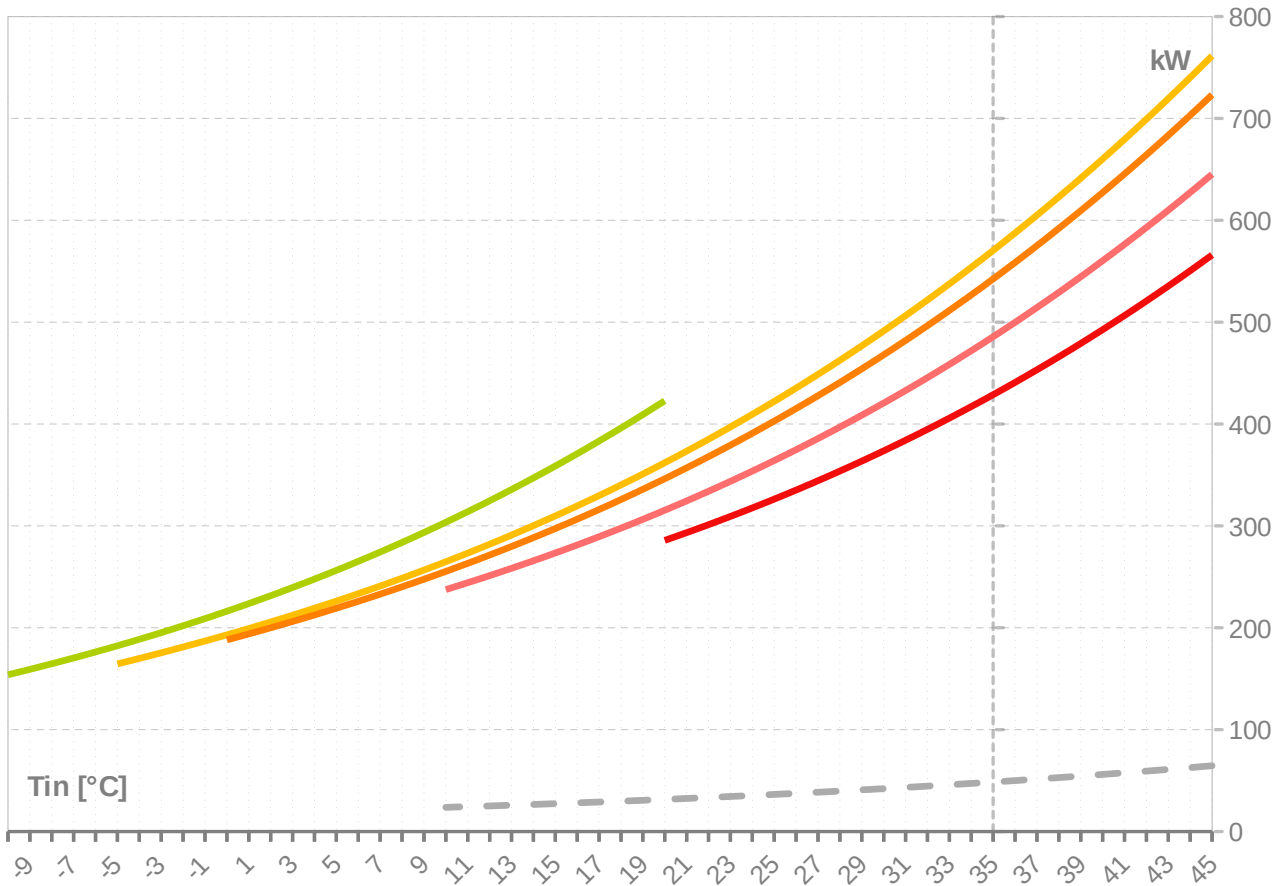

Performance lines - cooling

- Qc-nom-12-7
- Qc-nom-23-18

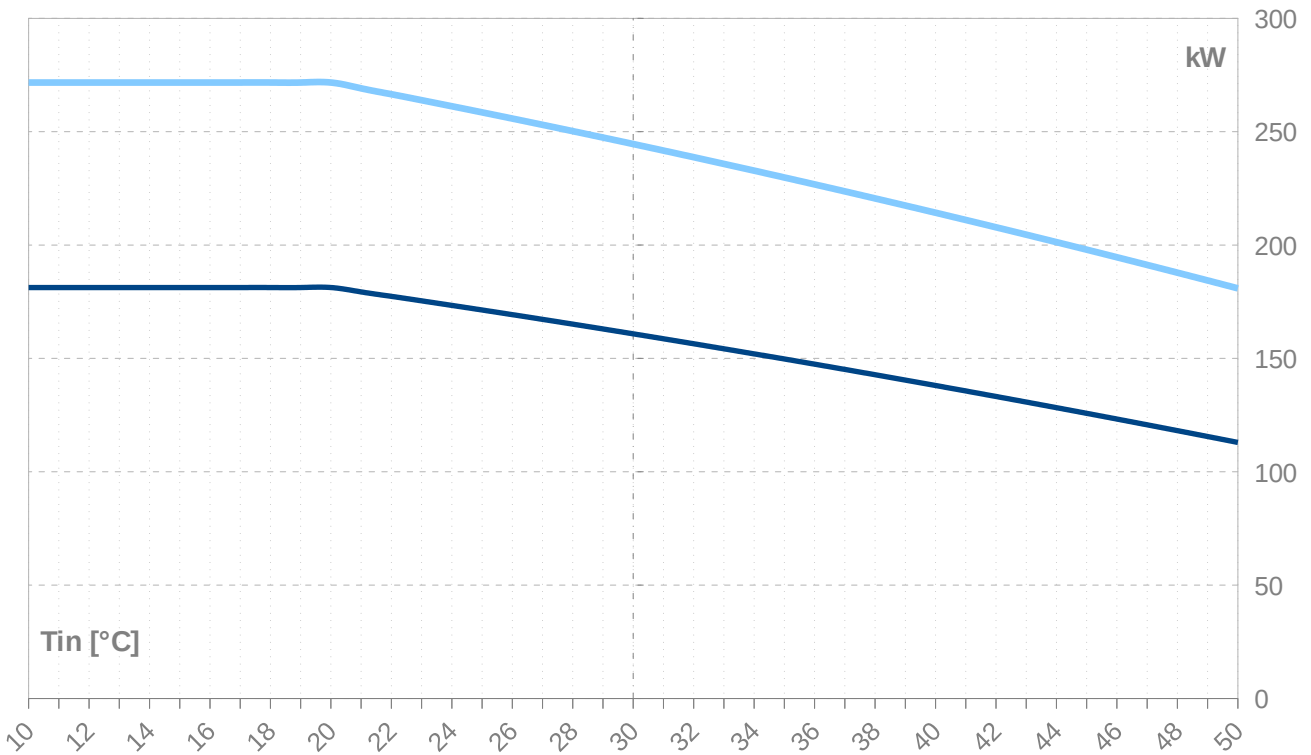

WAMAK TWW 550 WHR HeavyDuty 2L5

Th -OU	[°C]	55									
		Ts -IN [°C]	Qh nom [kW]	Qh min [kW]	Qh max [kW]	Pin nom [kW]	Pin min [kW]	Pin max [kW]	COP nom kW / kW	Qc nom [kW]	Qc min [kW]
45	761.4	76.1	761.4	81.7	7.9	81.7	9.32	685.6	68.6	685.6	146.6
44	740.2	74.0	740.2	81.5	7.9	81.5	9.09	664.7	66.5	664.7	146.3
43	719.5	71.9	719.5	81.2	7.9	81.2	8.86	644.2	64.4	644.2	146.0
42	699.2	69.9	699.2	80.9	7.8	80.9	8.64	624.2	62.4	624.2	145.7
41	679.5	67.9	679.5	80.7	7.8	80.7	8.42	604.6	60.5	604.6	145.4
40	660.2	66.0	660.2	80.4	7.8	80.4	8.21	585.6	58.6	585.6	145.1
39	641.3	64.1	641.3	80.2	7.8	80.2	8.00	566.9	56.7	566.9	144.8
38	622.9	62.3	622.9	80.0	7.8	80.0	7.79	548.8	54.9	548.8	144.5
37	605.0	60.5	605.0	79.7	7.7	79.7	7.59	531.1	53.1	531.1	144.2
36	587.5	58.7	587.5	79.5	7.7	79.5	7.39	513.8	51.4	513.8	143.9
35	570.4	57.0	570.4	79.3	7.7	79.3	7.20	496.9	49.7	496.9	143.7
34	553.8	55.4	553.8	79.1	7.7	79.1	7.00	480.5	48.0	480.5	143.4
33	537.6	53.8	537.6	78.9	7.6	78.9	6.82	464.5	46.4	464.5	143.2
32	521.8	52.2	521.8	78.7	7.6	78.7	6.63	448.8	44.9	448.8	142.9
31	506.4	50.6	506.4	78.5	7.6	78.5	6.45	433.6	43.4	433.6	142.7
30	491.4	49.1	491.4	78.3	7.6	78.3	6.28	418.8	41.9	418.8	142.5
29	476.8	47.7	476.8	78.1	7.6	78.1	6.11	404.4	40.4	404.4	142.3
28	462.6	46.3	462.6	77.9	7.6	77.9	5.94	390.3	39.0	390.3	142.0
27	448.8	44.9	448.8	77.7	7.5	77.7	5.77	376.7	37.7	376.7	141.8
26	435.3	43.5	435.3	77.6	7.5	77.6	5.61	363.4	36.3	363.4	141.6
25	422.2	42.2	422.2	77.4	7.5	77.4	5.45	350.4	35.0	350.4	141.5
24	409.5	40.9	409.5	77.2	7.5	77.2	5.30	337.8	33.8	337.8	141.3
23	397.1	39.7	397.1	77.1	7.5	77.1	5.15	325.6	32.6	325.6	141.1
22	385.0	38.5	385.0	76.9	7.5	76.9	5.00	313.7	31.4	313.7	140.9
21	373.3	37.3	373.3	76.8	7.4	76.8	4.86	302.1	30.2	302.1	140.8
20	361.9	36.2	361.9	76.7	7.4	76.7	4.72	290.8	29.1	290.8	140.6
19	350.9	35.1	350.9	76.6	7.4	76.6	4.58	279.9	28.0	279.9	140.5
18	340.2	34.0	340.2	76.4	7.4	76.4	4.45	269.3	26.9	269.3	140.3
17	329.7	33.0	329.7	76.3	7.4	76.3	4.32	258.9	25.9	258.9	140.2
16	319.6	32.0	319.6	76.2	7.4	76.2	4.19	248.9	24.9	248.9	140.1
15	309.8	31.0	309.8	76.1	7.4	76.1	4.07	239.2	23.9	239.2	140.0
14	300.2	30.0	300.2	76.0	7.4	76.0	3.95	229.7	23.0	229.7	139.8
13	291.0	29.1	291.0	75.9	7.4	75.9	3.83	220.6	22.1	220.6	139.7
12	282.0	28.2	282.0	75.8	7.4	75.8	3.72	211.6	21.2	211.6	139.6
11	273.3	27.3	273.3	75.8	7.3	75.8	3.61	203.0	20.3	203.0	139.6
10	264.8	26.5	264.8	75.7	7.3	75.7	3.50	194.6	19.5	194.6	139.5
9	256.6	25.7	256.6	75.6	7.3	75.6	3.39	186.5	18.6	186.5	139.4
8	248.6	24.9	248.6	75.5	7.3	75.5	3.29	178.6	17.9	178.6	139.3
7	240.9	24.1	240.9	75.5	7.3	75.5	3.19	170.9	17.1	170.9	139.3
6	233.4	23.3	233.4	75.4	7.3	75.4	3.09	163.5	16.3	163.5	139.2
5	226.2	22.6	226.2	75.4	7.3	75.4	3.00	156.3	15.6	156.3	139.2
4	219.1	21.9	219.1	75.4	7.3	75.4	2.91	149.3	14.9	149.3	139.1
3	212.3	21.2	212.3	75.3	7.3	75.3	2.82	142.5	14.2	142.5	139.1
2	205.7	20.6	205.7	75.3	7.3	75.3	2.73	135.9	13.6	135.9	139.0
1	199.3	19.9	199.3	75.3	7.3	75.3	2.65	129.5	12.9	129.5	139.0
0	193.0	19.3	193.0	75.3	7.3	75.3	2.57	123.2	12.3	123.2	139.0
-1	187.0	18.7	187.0	75.2	7.3	75.2	2.48	117.2	11.7	117.2	139.0
-2	181.1	18.1	181.1	75.2	7.3	75.2	2.41	111.3	11.1	111.3	139.0
-3	175.4	17.5	175.4	75.2	7.3	75.2	2.33	105.6	10.6	105.6	139.0
-4	169.9	17.0	169.9	75.3	7.3	75.3	2.26	100.1	10.0	100.1	139.0
-5	164.5	16.4	164.5	75.3	7.3	75.3	2.19	94.7	9.5	94.7	139.0

-- attention: operating limits not reflected in performance table

ZR144KRE-TFD_R513A_10_WHR

WAMAK TWW 550 WHR HeavyDuty 2L5

Th -OU	60										
[°C]	Qh nom	Qh min	Qh max	Pin nom	Pin min	Pin max	COP nom	Qc nom	Qc min	Qc max	I nom
[°C]	[kW]	[kW]	[kW]	[kW]	[kW]	[kW]	kw / kw	[kW]	[kW]	[kW]	[A]
45	723.2	72.3	723.2	88.6	8.6	88.6	8.16	641.0	64.1	641.0	155.1
44	703.1	70.3	703.1	88.4	8.6	88.4	7.95	621.1	62.1	621.1	154.8
43	683.4	68.3	683.4	88.2	8.5	88.2	7.75	601.6	60.2	601.6	154.5
42	664.2	66.4	664.2	88.0	8.5	88.0	7.55	582.7	58.3	582.7	154.2
41	645.5	64.6	645.5	87.8	8.5	87.8	7.36	564.1	56.4	564.1	154.0
40	627.3	62.7	627.3	87.5	8.5	87.5	7.16	546.0	54.6	546.0	153.7
39	609.4	60.9	609.4	87.4	8.5	87.4	6.98	528.4	52.8	528.4	153.5
38	592.0	59.2	592.0	87.2	8.5	87.2	6.79	511.2	51.1	511.2	153.3
37	575.1	57.5	575.1	87.0	8.4	87.0	6.61	494.4	49.4	494.4	153.0
36	558.6	55.9	558.6	86.8	8.4	86.8	6.44	478.1	47.8	478.1	152.8
35	542.5	54.2	542.5	86.6	8.4	86.6	6.26	462.1	46.2	462.1	152.6
34	526.8	52.7	526.8	86.4	8.4	86.4	6.09	446.6	44.7	446.6	152.4
33	511.5	51.1	511.5	86.3	8.4	86.3	5.93	431.4	43.1	431.4	152.2
32	496.6	49.7	496.6	86.1	8.4	86.1	5.77	416.7	41.7	416.7	152.0
31	482.1	48.2	482.1	86.0	8.3	86.0	5.61	402.3	40.2	402.3	151.8
30	467.9	46.8	467.9	85.8	8.3	85.8	5.45	388.3	38.8	388.3	151.6
29	454.2	45.4	454.2	85.7	8.3	85.7	5.30	374.7	37.5	374.7	151.5
28	440.8	44.1	440.8	85.5	8.3	85.5	5.15	361.5	36.1	361.5	151.3
27	427.8	42.8	427.8	85.4	8.3	85.4	5.01	348.6	34.9	348.6	151.1
26	415.1	41.5	415.1	85.3	8.3	85.3	4.87	336.0	33.6	336.0	151.0
25	402.8	40.3	402.8	85.2	8.3	85.2	4.73	323.8	32.4	323.8	150.8
24	390.9	39.1	390.9	85.0	8.2	85.0	4.60	312.0	31.2	312.0	150.7
23	379.2	37.9	379.2	84.9	8.2	84.9	4.47	300.5	30.0	300.5	150.6
22	367.9	36.8	367.9	84.8	8.2	84.8	4.34	289.3	28.9	289.3	150.5
21	356.9	35.7	356.9	84.7	8.2	84.7	4.21	278.4	27.8	278.4	150.3
20	346.3	34.6	346.3	84.6	8.2	84.6	4.09	267.8	26.8	267.8	150.2
19	335.9	33.6	335.9	84.5	8.2	84.5	3.97	257.5	25.7	257.5	150.1
18	325.8	32.6	325.8	84.5	8.2	84.5	3.86	247.5	24.8	247.5	150.0
17	316.1	31.6	316.1	84.4	8.2	84.4	3.75	237.8	23.8	237.8	149.9
16	306.6	30.7	306.6	84.3	8.2	84.3	3.64	228.4	22.8	228.4	149.9
15	297.4	29.7	297.4	84.2	8.2	84.2	3.53	219.3	21.9	219.3	149.8
14	288.5	28.8	288.5	84.2	8.2	84.2	3.43	210.4	21.0	210.4	149.7
13	279.8	28.0	279.8	84.1	8.2	84.1	3.33	201.8	20.2	201.8	149.6
12	271.4	27.1	271.4	84.1	8.2	84.1	3.23	193.4	19.3	193.4	149.6
11	263.2	26.3	263.2	84.0	8.1	84.0	3.13	185.3	18.5	185.3	149.5
10	255.3	25.5	255.3	84.0	8.1	84.0	3.04	177.4	17.7	177.4	149.5
9	247.6	24.8	247.6	83.9	8.1	83.9	2.95	169.8	17.0	169.8	149.5
8	240.2	24.0	240.2	83.9	8.1	83.9	2.86	162.4	16.2	162.4	149.4
7	233.0	23.3	233.0	83.9	8.1	83.9	2.78	155.2	15.5	155.2	149.4
6	226.0	22.6	226.0	83.9	8.1	83.9	2.69	148.2	14.8	148.2	149.4
5	219.2	21.9	219.2	83.8	8.1	83.8	2.61	141.4	14.1	141.4	149.4
4	212.6	21.3	212.6	83.8	8.1	83.8	2.54	134.8	13.5	134.8	149.4
3	206.2	20.6	206.2	83.8	8.1	83.8	2.46	128.4	12.8	128.4	149.4
2	200.0	20.0	200.0	83.8	8.1	83.8	2.39	122.2	12.2	122.2	149.4
1	193.9	19.4	193.9	83.8	8.1	83.8	2.31	116.2	11.6	116.2	149.4
0	188.1	18.8	188.1	83.9	8.1	83.9	2.24	110.3	11.0	110.3	149.4
-1											
-2											
-3											
-4											
-5											

-- attention: operating limits not reflected in performance table

WAMAK TWW 550 WHR HeavyDuty 2L5

Th -OU	70										
Th -OU	Qh nom	Qh min	Qh max	Pin nom	Pin min	Pin max	COP nom	Qc nom	Qc min	Qc max	I nom
[°C]	[kW]	[kW]	[kW]	[kW]	[kW]	[kW]	kW / kW	[kW]	[kW]	[kW]	[A]
45	645.2	64.5	645.2	105.2	10.2	105.2	6.13	547.6	54.8	547.6	176.4
44	627.3	62.7	627.3	105.1	10.2	105.1	5.97	529.8	53.0	529.8	176.2
43	609.9	61.0	609.9	105.0	10.2	105.0	5.81	512.5	51.3	512.5	176.1
42	592.9	59.3	592.9	104.9	10.2	104.9	5.65	495.6	49.6	495.6	175.9
41	576.4	57.6	576.4	104.8	10.2	104.8	5.50	479.2	47.9	479.2	175.8
40	560.3	56.0	560.3	104.7	10.2	104.7	5.35	463.1	46.3	463.1	175.7
39	544.6	54.5	544.6	104.7	10.1	104.7	5.20	447.5	44.7	447.5	175.6
38	529.3	52.9	529.3	104.6	10.1	104.6	5.06	432.2	43.2	432.2	175.5
37	514.3	51.4	514.3	104.5	10.1	104.5	4.92	417.4	41.7	417.4	175.4
36	499.8	50.0	499.8	104.4	10.1	104.4	4.79	403.0	40.3	403.0	175.3
35	485.7	48.6	485.7	104.4	10.1	104.4	4.65	388.9	38.9	388.9	175.2
34	472.0	47.2	472.0	104.3	10.1	104.3	4.52	375.2	37.5	375.2	175.1
33	458.6	45.9	458.6	104.3	10.1	104.3	4.40	361.9	36.2	361.9	175.1
32	445.6	44.6	445.6	104.2	10.1	104.2	4.28	348.9	34.9	348.9	175.0
31	432.9	43.3	432.9	104.1	10.1	104.1	4.16	336.3	33.6	336.3	174.9
30	420.6	42.1	420.6	104.1	10.1	104.1	4.04	324.0	32.4	324.0	174.9
29	408.6	40.9	408.6	104.1	10.1	104.1	3.93	312.1	31.2	312.1	174.8
28	397.0	39.7	397.0	104.0	10.1	104.0	3.82	300.5	30.1	300.5	174.8
27	385.7	38.6	385.7	104.0	10.1	104.0	3.71	289.3	28.9	289.3	174.7
26	374.7	37.5	374.7	104.0	10.1	104.0	3.60	278.3	27.8	278.3	174.7
25	364.1	36.4	364.1	104.0	10.1	104.0	3.50	267.7	26.8	267.7	174.7
24	353.7	35.4	353.7	103.9	10.1	103.9	3.40	257.3	25.7	257.3	174.7
23	343.7	34.4	343.7	103.9	10.1	103.9	3.31	247.3	24.7	247.3	174.7
22	334.0	33.4	334.0	103.9	10.1	103.9	3.21	237.6	23.8	237.6	174.7
21	324.5	32.4	324.5	103.9	10.1	103.9	3.12	228.1	22.8	228.1	174.7
20	315.3	31.5	315.3	103.9	10.1	103.9	3.03	218.9	21.9	218.9	174.7
19	306.4	30.6	306.4	103.9	10.1	103.9	2.95	210.0	21.0	210.0	174.7
18	297.8	29.8	297.8	103.9	10.1	103.9	2.87	201.4	20.1	201.4	174.7
17	289.4	28.9	289.4	103.9	10.1	103.9	2.78	193.0	19.3	193.0	174.7
16	281.3	28.1	281.3	104.0	10.1	104.0	2.71	184.8	18.5	184.8	174.8
15	273.4	27.3	273.4	104.0	10.1	104.0	2.63	176.9	17.7	176.9	174.8
14	265.8	26.6	265.8	104.0	10.1	104.0	2.55	169.3	16.9	169.3	174.8
13	258.3	25.8	258.3	104.0	10.1	104.0	2.48	161.8	16.2	161.8	174.9
12	251.2	25.1	251.2	104.1	10.1	104.1	2.41	154.6	15.5	154.6	174.9
11	244.2	24.4	244.2	104.1	10.1	104.1	2.35	147.6	14.8	147.6	175.0
10	237.5	23.7	237.5	104.2	10.1	104.2	2.28	140.8	14.1	140.8	175.1
9											
8											
7											
6											
5											

-- attention: operating limits not reflected in performance table

WAMAK TWW 550 WHR HeavyDuty 2L5

Th -OU	80										
[°C]	Qh nom	Qh min	Qh max	Pin nom	Pin min	Pin max	COP nom	Qc nom	Qc min	Qc max	I nom
[°C]	[kW]	[kW]	[kW]	[kW]	[kW]	[kW]	kW / kW	[kW]	[kW]	[kW]	[A]
45	566.0	56.6	566.0	126.5	12.3	126.5	4.47	448.6	44.9	448.6	205.0
44	550.5	55.1	550.5	126.6	12.3	126.6	4.35	433.1	43.3	433.1	205.1
43	535.4	53.5	535.4	126.6	12.3	126.6	4.23	418.0	41.8	418.0	205.1
42	520.8	52.1	520.8	126.7	12.3	126.7	4.11	403.3	40.3	403.3	205.1
41	506.5	50.7	506.5	126.7	12.3	126.7	4.00	389.0	38.9	389.0	205.2
40	492.6	49.3	492.6	126.8	12.3	126.8	3.89	375.1	37.5	375.1	205.2
39	479.1	47.9	479.1	126.8	12.3	126.8	3.78	361.5	36.2	361.5	205.3
38	466.0	46.6	466.0	126.9	12.3	126.9	3.67	348.3	34.8	348.3	205.4
37	453.2	45.3	453.2	126.9	12.3	126.9	3.57	335.5	33.6	335.5	205.4
36	440.9	44.1	440.9	127.0	12.3	127.0	3.47	323.0	32.3	323.0	205.5
35	428.8	42.9	428.8	127.1	12.3	127.1	3.37	310.9	31.1	310.9	205.6
34	417.1	41.7	417.1	127.2	12.3	127.2	3.28	299.2	29.9	299.2	205.7
33	405.7	40.6	405.7	127.2	12.3	127.2	3.19	287.7	28.8	287.7	205.8
32	394.7	39.5	394.7	127.3	12.3	127.3	3.10	276.6	27.7	276.6	205.9
31	384.0	38.4	384.0	127.4	12.4	127.4	3.01	265.8	26.6	265.8	206.0
30	373.6	37.4	373.6	127.5	12.4	127.5	2.93	255.4	25.5	255.4	206.1
29	363.6	36.4	363.6	127.6	12.4	127.6	2.85	245.2	24.5	245.2	206.2
28	353.8	35.4	353.8	127.7	12.4	127.7	2.77	235.4	23.5	235.4	206.3
27	344.3	34.4	344.3	127.8	12.4	127.8	2.69	225.8	22.6	225.8	206.4
26	335.1	33.5	335.1	127.9	12.4	127.9	2.62	216.5	21.7	216.5	206.6
25	326.2	32.6	326.2	128.0	12.4	128.0	2.55	207.5	20.8	207.5	206.7
24	317.6	31.8	317.6	128.1	12.4	128.1	2.48	198.8	19.9	198.8	206.9
23	309.3	30.9	309.3	128.2	12.4	128.2	2.41	190.3	19.0	190.3	207.0
22	301.2	30.1	301.2	128.3	12.4	128.3	2.35	182.1	18.2	182.1	207.2
21	293.3	29.3	293.3	128.5	12.5	128.5	2.28	174.2	17.4	174.2	207.3
20	285.8	28.6	285.8	128.6	12.5	128.6	2.22	166.5	16.6	166.5	207.5
19											
18											
17											
16											
15											
14											
13											
12											
11											
10											
9											
8											
7											
6											
5											

-- attention: operating limits not reflected in performance table

WAMAK TWW 550 WHR HeavyDuty 2L5

Tc -OU		W 12 / 7 °C									
°C	Qc nom	Qc min	Qc max	Pin nom	Pin min	Pin max	EER	Qh nom	Qh min	Qh max	I nom
[°C]	[kW]	[kW]	[kW]	[kW]	[kW]	[kW]	kW / kW	[kW]	[kW]	[kW]	[A]
40	138.0	13.8	138.0	66.4	6.4	66.4	2.08	199.6	20.0	199.6	128.7
39	140.4	14.0	140.4	65.0	6.3	65.0	2.16	200.7	20.1	200.7	127.2
38	142.8	14.3	142.8	63.7	6.2	63.7	2.24	201.9	20.2	201.9	125.7
37	145.1	14.5	145.1	62.5	6.1	62.5	2.32	203.1	20.3	203.1	124.3
36	147.4	14.7	147.4	61.2	5.9	61.2	2.41	204.2	20.4	204.2	123.0
35	149.7	15.0	149.7	60.0	5.8	60.0	2.49	205.4	20.5	205.4	121.7
34	152.0	15.2	152.0	58.9	5.7	58.9	2.58	206.6	20.7	206.6	120.4
33	154.2	15.4	154.2	57.7	5.6	57.7	2.67	207.8	20.8	207.8	119.2
32	156.5	15.6	156.5	56.6	5.5	56.6	2.76	209.0	20.9	209.0	118.1
31	158.7	15.9	158.7	55.5	5.4	55.5	2.86	210.2	21.0	210.2	117.0
30	160.8	16.1	160.8	54.5	5.3	54.5	2.95	211.4	21.1	211.4	115.9
29	163.0	16.3	163.0	53.5	5.2	53.5	3.05	212.6	21.3	212.6	114.8
28	165.1	16.5	165.1	52.5	5.1	52.5	3.15	213.8	21.4	213.8	113.8
27	167.2	16.7	167.2	51.5	5.0	51.5	3.25	215.0	21.5	215.0	112.9
26	169.3	16.9	169.3	50.6	4.9	50.6	3.35	216.2	21.6	216.2	111.9
25	171.4	17.1	171.4	49.7	4.8	49.7	3.45	217.4	21.7	217.4	111.1
24	173.4	17.3	173.4	48.8	4.7	48.8	3.56	218.6	21.9	218.6	110.2
23	175.4	17.5	175.4	47.9	4.6	47.9	3.66	219.8	22.0	219.8	109.4
22	177.4	17.7	177.4	47.0	4.6	47.0	3.77	221.0	22.1	221.0	108.5
21	179.3	17.9	179.3	46.2	4.5	46.2	3.88	222.2	22.2	222.2	107.8
20	181.3	18.1	181.3	45.4	4.4	45.4	4.00	223.3	22.3	223.3	107.0

Tc [°C]		W 23 / 18 °C									
0	Qc nom	Qc min	Qc max	Pin nom	Pin min	Pin max	EER	Qh nom	Qh min	Qh max	I nom
[°C]	[kW]	[kW]	[kW]	[kW]	[kW]	[kW]	kW / kW	[kW]	[kW]	[kW]	[A]
40	214.3	21.4	214.3	66.4	6.4	66.4	3.23	276.5	27.6	257.2	129.5
39	217.4	21.7	217.4	65.0	6.3	65.0	3.34	278.4	27.8	259.1	128.0
38	220.6	22.1	220.6	63.7	6.2	63.7	3.46	280.4	28.0	261.0	126.6
37	223.7	22.4	223.7	62.5	6.1	62.5	3.58	282.3	28.2	262.9	125.2
36	226.8	22.7	226.8	61.2	5.9	61.2	3.70	284.3	28.4	264.8	123.9
35	229.8	23.0	229.8	60.0	5.8	60.0	3.83	286.3	28.6	266.7	122.6
34	232.8	23.3	232.8	58.9	5.7	58.9	3.95	288.2	28.8	268.7	121.4
33	235.8	23.6	235.8	57.7	5.6	57.7	4.08	290.2	29.0	270.6	120.2
32	238.7	23.9	238.7	56.6	5.5	56.6	4.22	292.1	29.2	272.6	119.1
31	241.7	24.2	241.7	55.5	5.4	55.5	4.35	294.0	29.4	274.5	117.9
30	244.6	24.5	244.6	54.5	5.3	54.5	4.49	296.0	29.6	276.5	116.9
29	247.4	24.7	247.4	53.5	5.2	53.5	4.63	297.9	29.8	278.4	115.8
28	250.2	25.0	250.2	52.5	5.1	52.5	4.77	299.8	30.0	280.4	114.8
27	253.0	25.3	253.0	51.5	5.0	51.5	4.91	301.7	30.2	282.3	113.8
26	255.8	25.6	255.8	50.6	4.9	50.6	5.06	303.6	30.4	284.3	112.9
25	258.5	25.9	258.5	49.7	4.8	49.7	5.21	305.4	30.5	286.3	112.0
24	261.2	26.1	261.2	48.8	4.7	48.8	5.36	307.3	30.7	288.2	111.1
23	263.9	26.4	263.9	47.9	4.6	47.9	5.51	309.1	30.9	290.2	110.2
22	266.5	26.7	266.5	47.0	4.6	47.0	5.67	310.9	31.1	292.1	109.4
21	269.1	26.9	269.1	46.2	4.5	46.2	5.83	312.8	31.3	294.0	108.6
20	271.7	27.2	271.7	45.4	4.4	45.4	5.99	314.5	31.5	296.0	107.8

-- attention: operating limits not reflected in performance table

LEGEND:

Ts-IN: Temperature renewable source - inlet [°C]
Th-OU: Temperature heating - outlet (flow) [°C]
Tc-OU: Temperature cooling - outlet (flow) [°C]
Qh nom: Heating capacity nominal
Qh min: Heating capacity minimal
Qh max: Heating capacity maximal
Pin nom: Power input at nominal heating capacity
Pin min: Power input at minimal heating capacity
Pin max: Power input at maximal heating capacity
COP nom: coefficient of performance at nominal heating capacity
Qc nom: cooling / heat extraction capacity at nominal heating capacity
Qc min: cooling / heat extraction at minimal heating capacity
Qc max: cooling / heat extraction at maximal heating capacity
I nom: Current at nominal heating capacity
EER: energy efficiency ratio at nominal cooling capacity

Operating limits

Temp °C

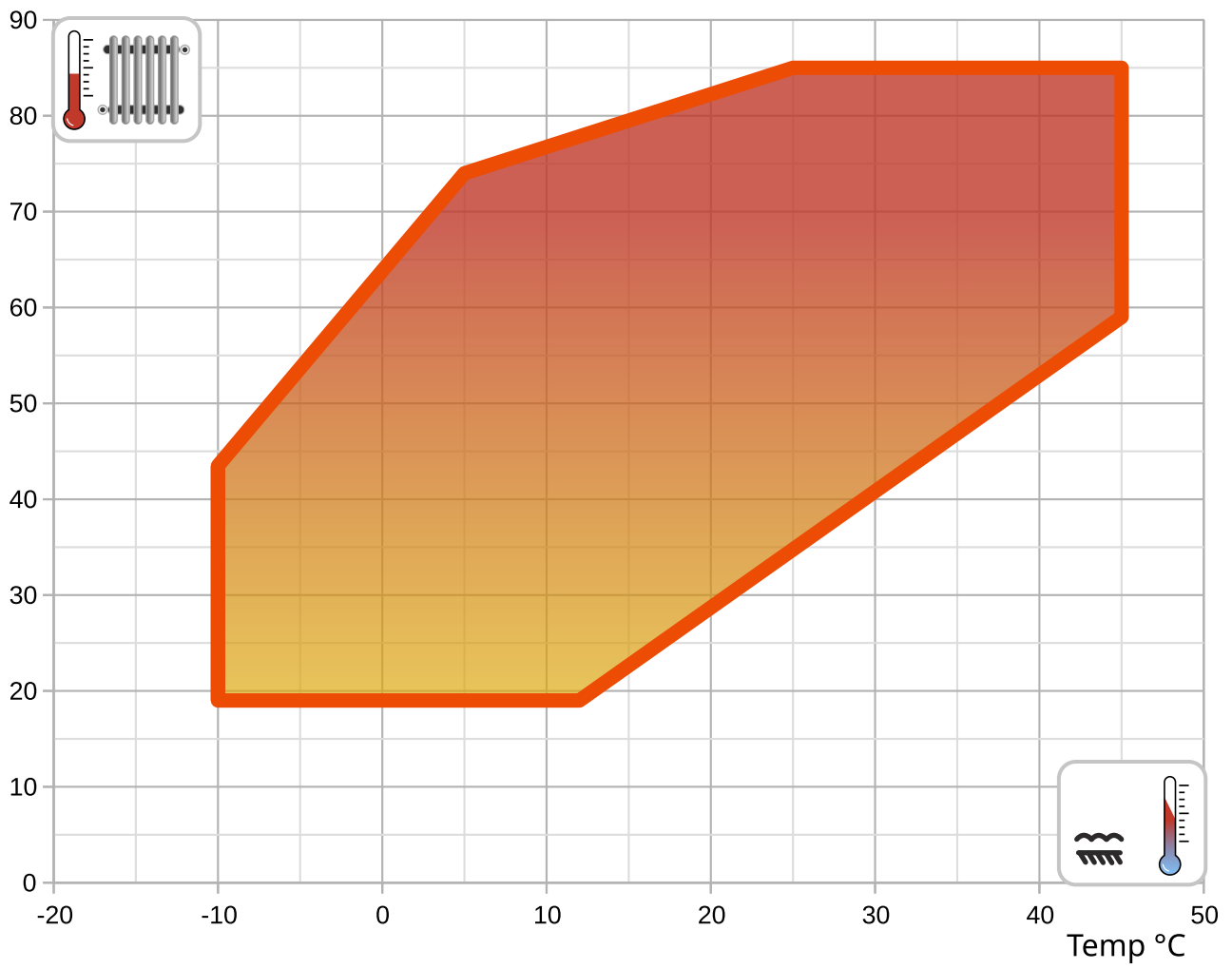

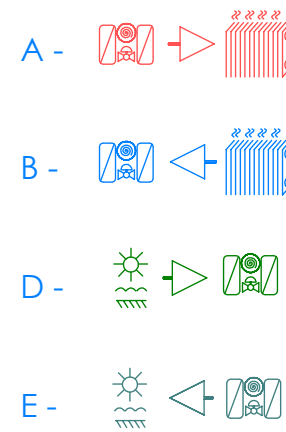
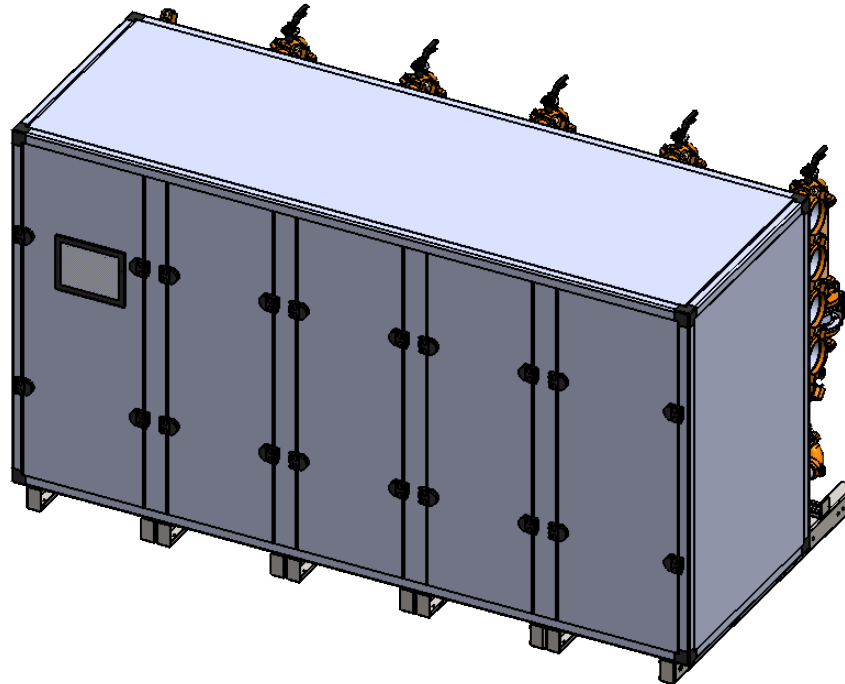
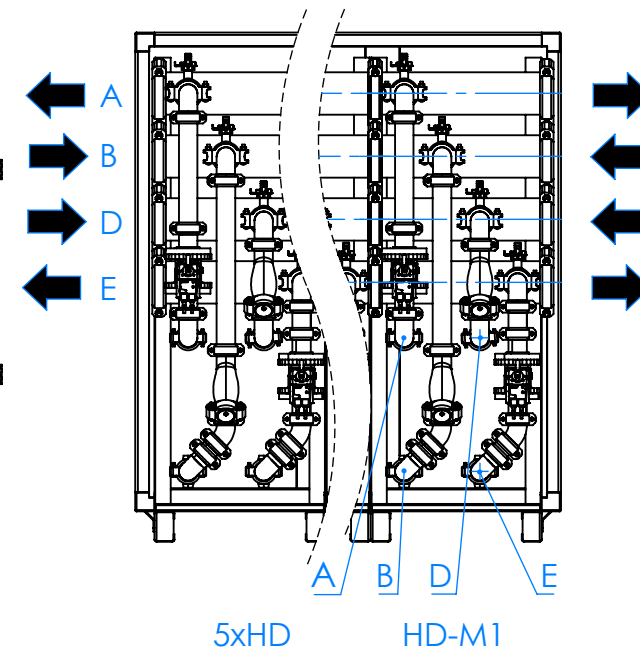
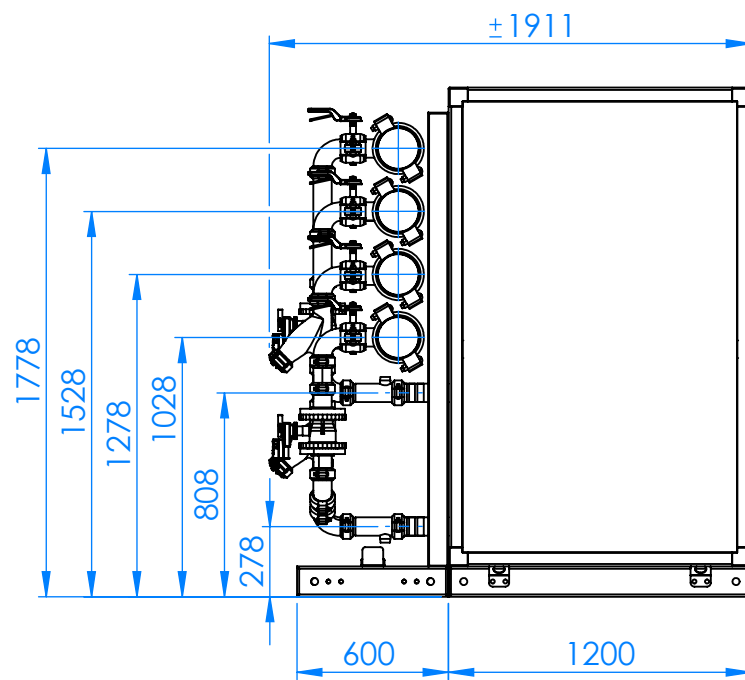
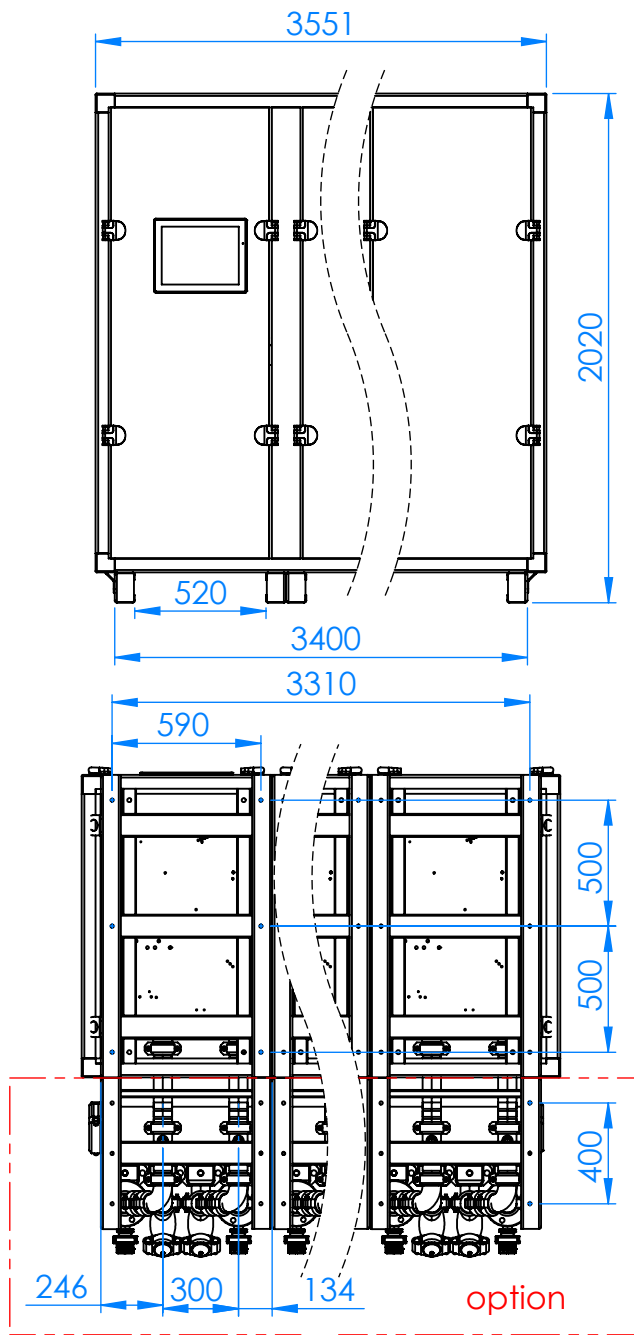

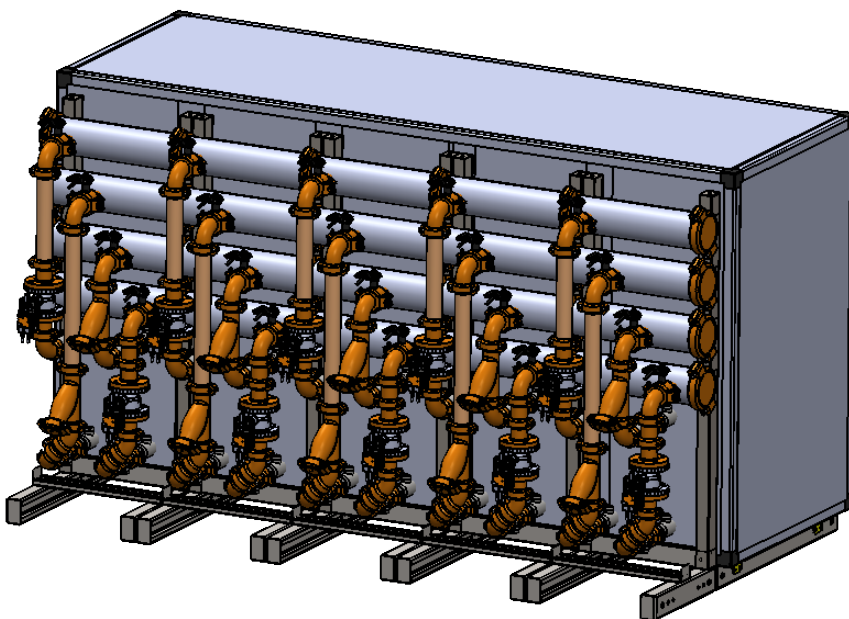
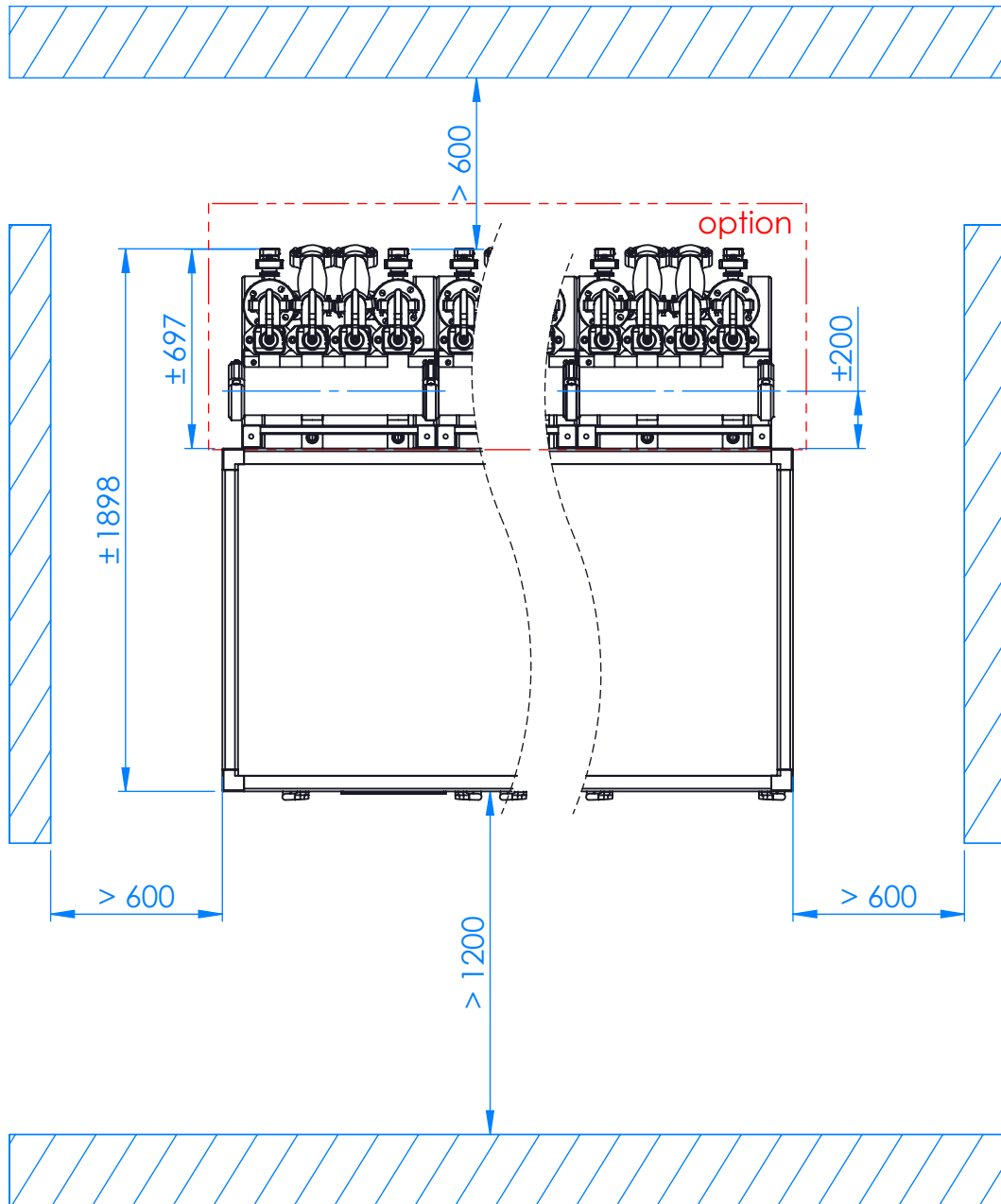

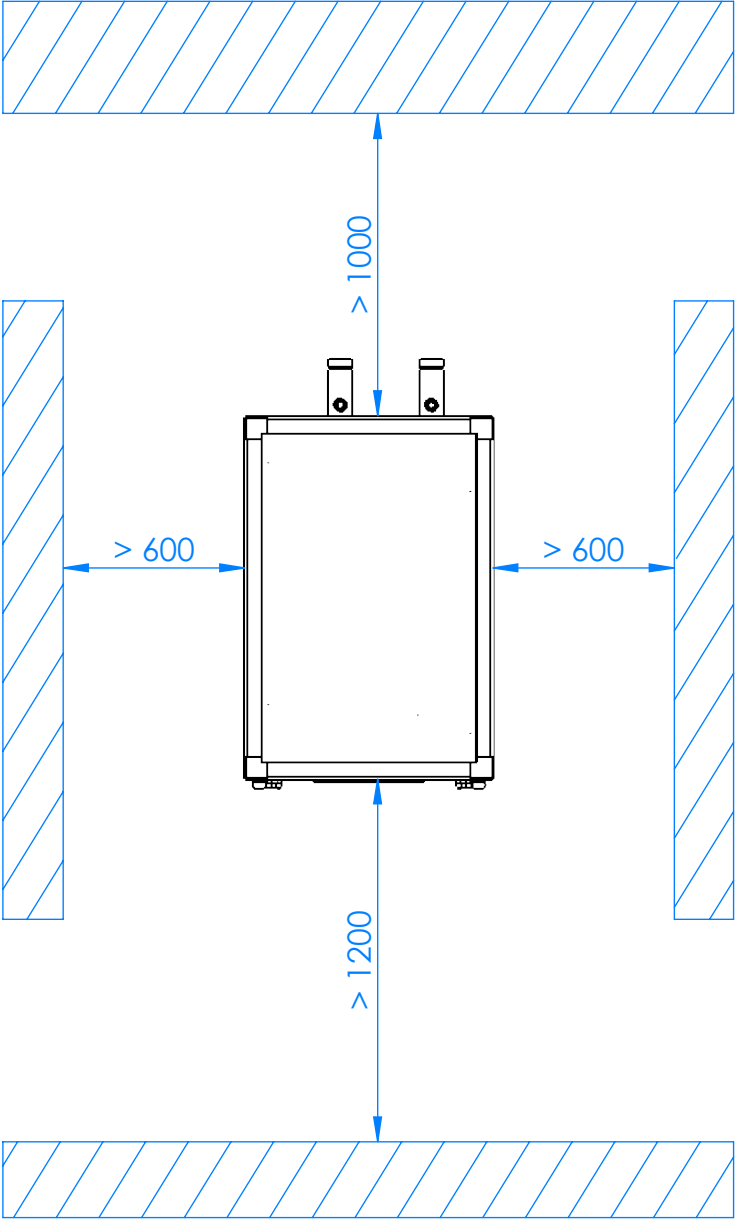

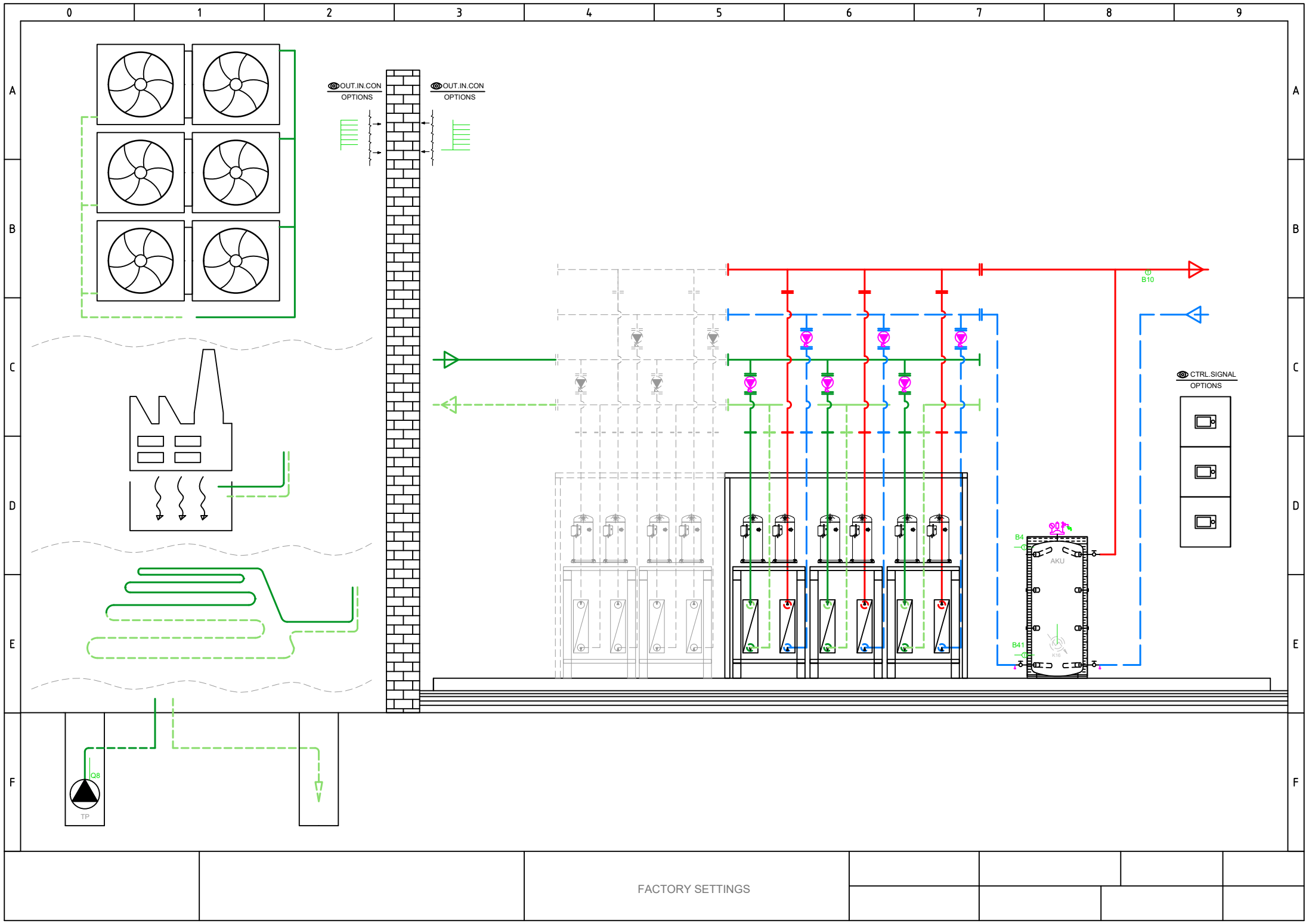

Total: max 6A
1 x QX...: max 2A

Main power supply 230V / 50 Hz
Ground
Neutral conductor

- E9 Low-pressure switch E9
- E10 High-pressure switch E10
- E15 Flow switch source E15
- E24 Flow switch consumers E24
- E6 Electrical utility lock E6
- E12 Overload compressor 2 E12
- E21 Mains supervision E21
- E22 Mains supervision E22
- E23 Mains supervision E23
- E11 Overload compressor 1 E11
- K1 Compressor stage 1 K1

Q8 Source pump Q8

Q9 Condenser pump Q9

K10 Alarm output K10

K40 Crankcase heater K40

K81 Valve evaporator K81

K82 Valve EVI K82

K2 Compressor stage 2 K2

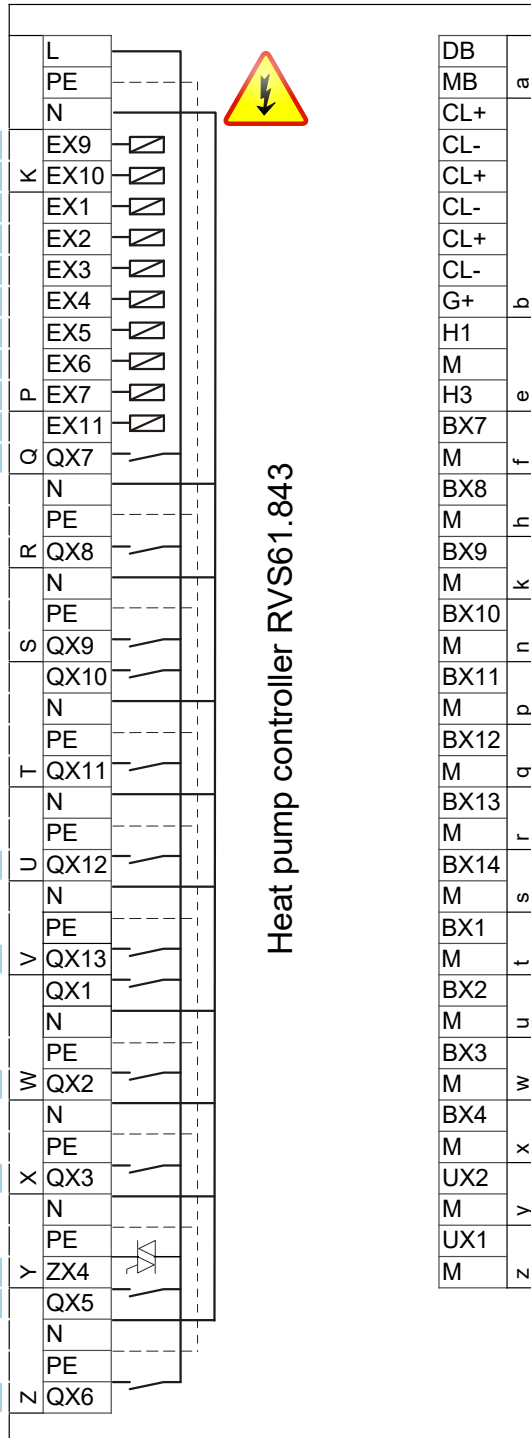

- DB LPB Bus data
- MB LPB Bus GND
- CL+ Room unit QAA...
- CL- Room unit QAA...
- CL+ Room unit QAA... 2.
- CL- Room unit QAA... 2.
- CL+ Room unit QAA... 3.
- CL- Room unit QAA... 3.
- G+ 12V supply → OUT
- H1
- M
- H3 Consumer request VK1
- BX7 B81 Hot-gas sensor K1 B81
- M
- BX8
- M
- BX9
- M
- BX10 B21 HP flow sensor B21
- M
- BX11
- M
- BX12 B71 HP return sensor B71
- M
- BX13 B91 Source inlet sensor B91
- M
- BX14 B84 Source outl sens B92/B84
- M
- BX1
- M
- BX2
- M
- BX3 B83 Refrig sensor liquid B83
- M
- BX4 B82 Hot-gas sensor K2 B82
- M
- UX2 Condenser pump Q9
- M
- UX1 0..10 V Signal
- M
- Z 0..10 V Signal



- AVS75.390
- AVS75.391
- AVS75.370

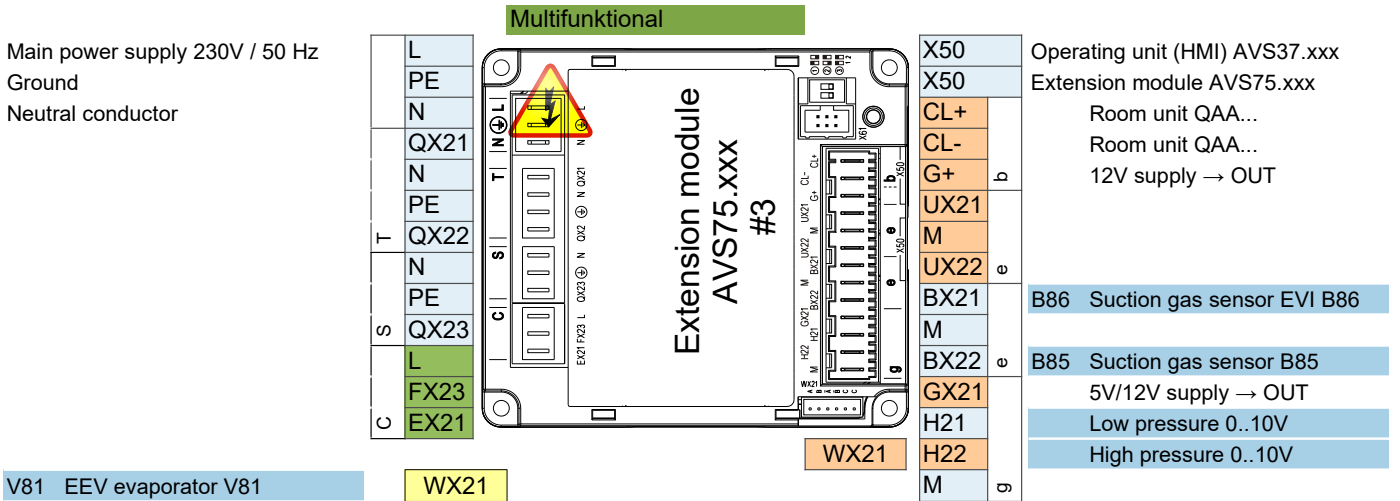
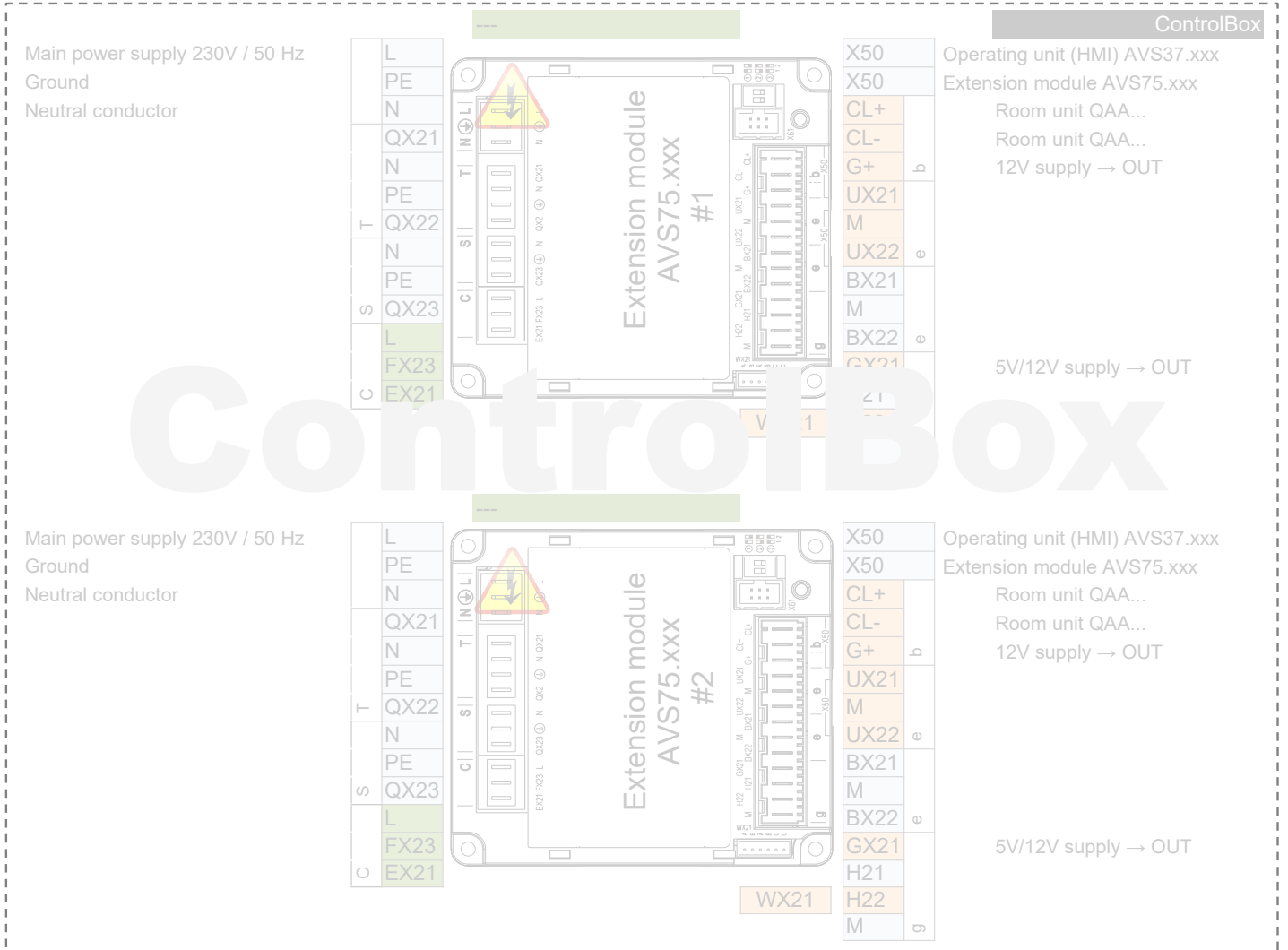

HEAT PUMP

EXTERNAL
INTERNAL

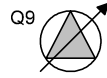
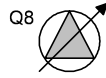

K1

K2

K82

K81

K40

K10

Q8 UX1

Q9 UX2

E11
KRW1
F1K
E11

E12
KRW2
F2K
E12

E6

E24
Q9.ERR
F1S
E24

E15
Q8.ERR
F1Z
E15

E10

E9



M-K1
MV-EVI-K1
Q1K

M-K1
MV-EVI-K2
Q2K

230V,50Hz
max 6A

0...10V

230V,50Hz
max 6A

0...10V

DO

DI

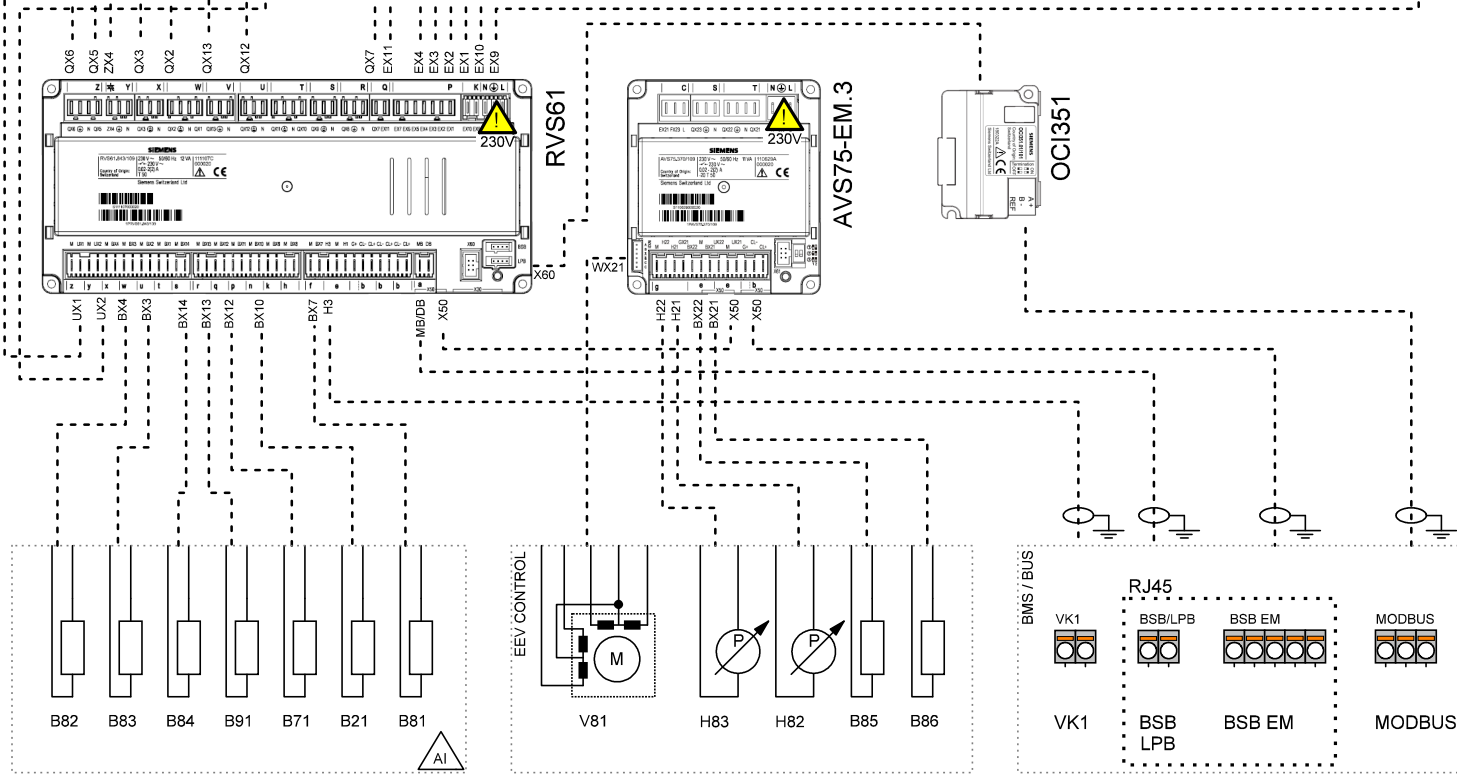
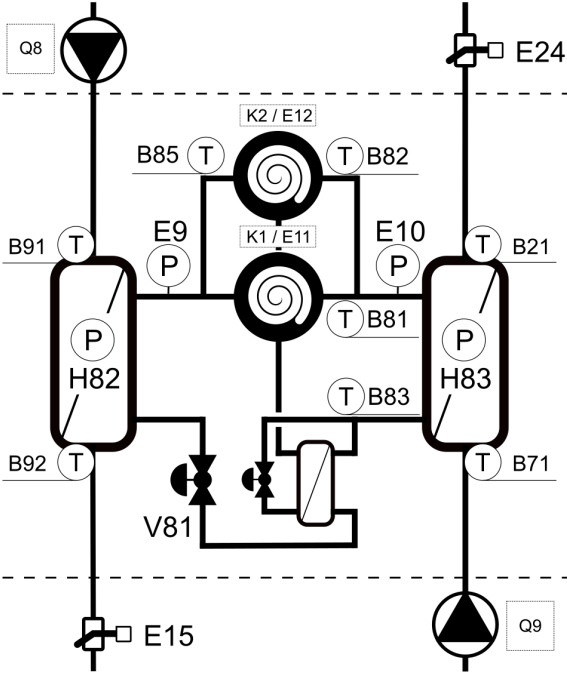

PWR SPLY: 3~ 400V, 50 Hz
CTRL: 1~ 230V, 50 HZ

Company	Title	Version / Note	Number	Created by	Date	Page
	TBW-TWW	05/2024				1

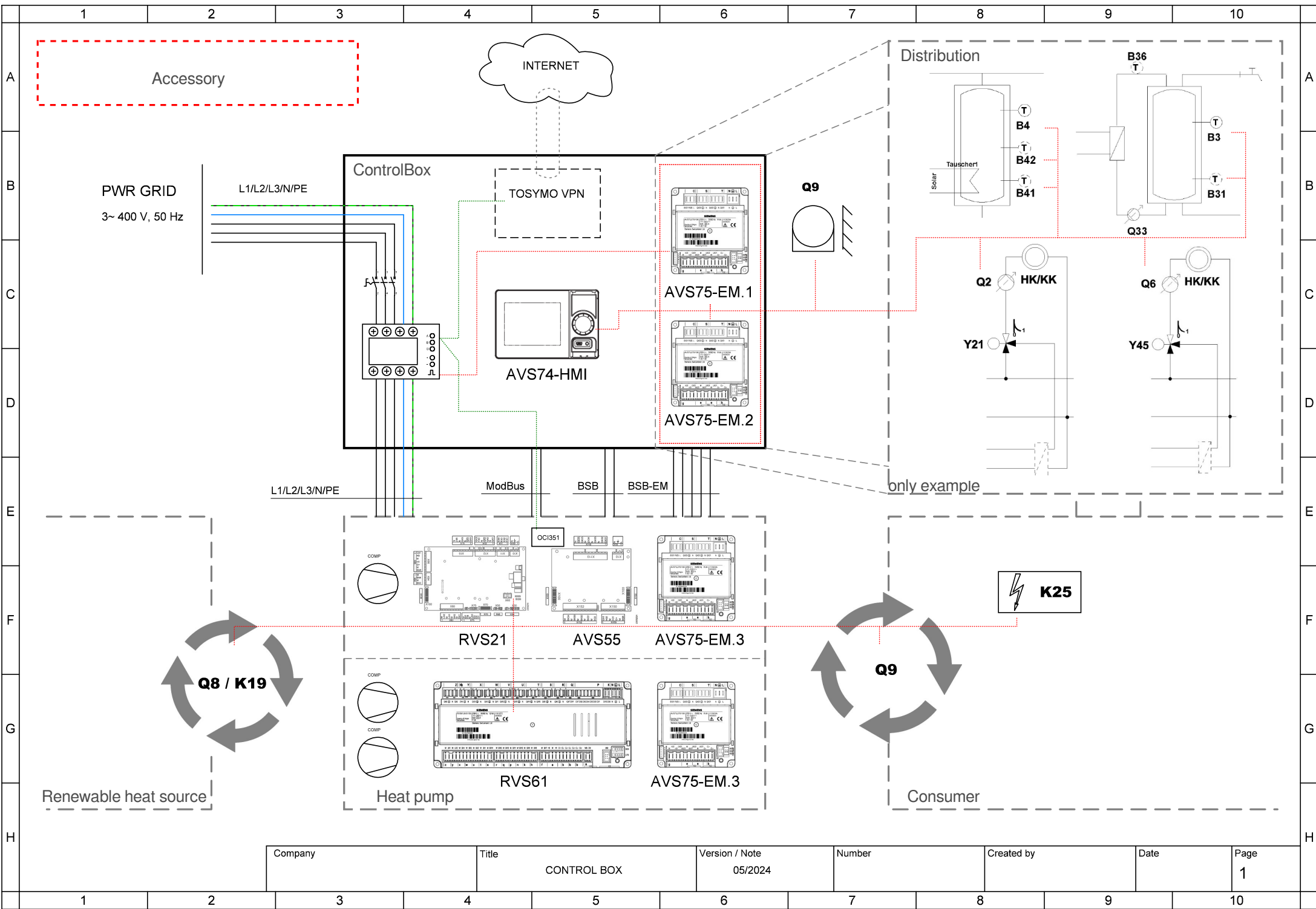

Company	Title	Version / Note	Number	Created by	Date	Page
	CONTROL BOX	05/2024				1



Company	Title	Version / Note	Number	Created by	Date	Page
	CONTROL BOX	05/2024				2



Company	Title	Version / Note	Number	Created by	Date	Page
	CONTROL BOX	05/2024				3



Company	Title	Version / Note	Number	Created by	Date	Page
	CONTROL BOX	05/2024				4

- AVS75.390
- AVS75.391
- AVS75.370

- AVS75.370**
 Main power supply 230V / 50 Hz
 Ground
 Neutral conductor
Y1 Mixing valve Open

Y2 Mixing valve Close

Q2 Heat circuit pump HC1 Q2

L Phase 230V
E61 Smart grid E61

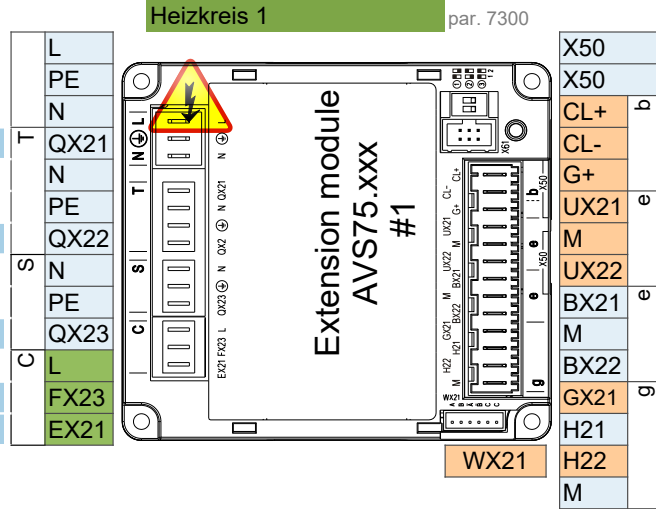

- Extension module AVS75.xxx
 Room unit QAA...
 Room unit QAA...

B1 Flow sensor 1

 Pulse count

- AVS75.370**
 Main power supply 230V / 50 Hz
 Ground
 Neutral conductor
Q3 DHW ctrl elem Q3

K6 El imm heater DHW K6

Q6 Heat circuit pump HC2 Q6

L Phase 230V
E62 Smart grid E62

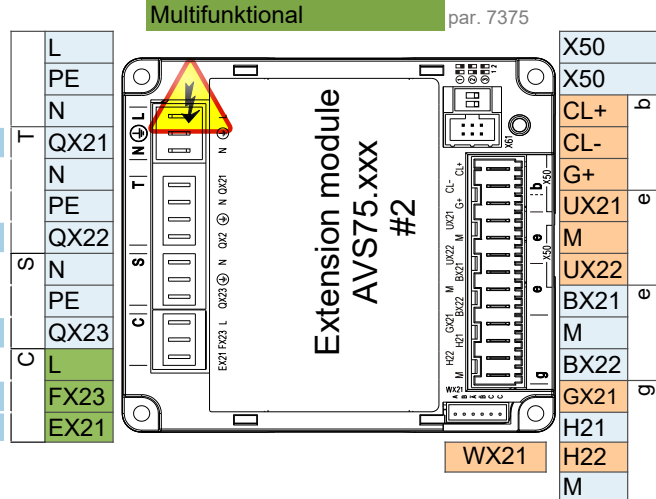

- Operating unit (HMI) AVS37.xxx
 Extension module AVS75.xxx
 Room unit QAA...
 Room unit QAA...

B3 DHW sensor B3

B4 Buffer sensor B4

- Main power supply 230V / 50 Hz
 Ground
 Neutral conductor

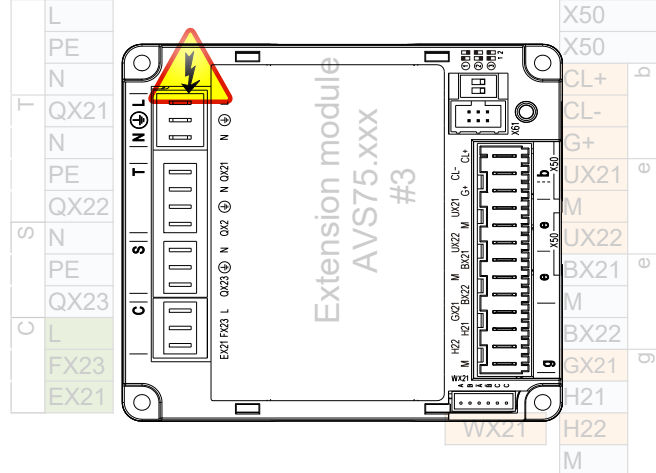

- Operating unit (HMI) AVS37.xxx
 Extension module AVS75.xxx
 Room unit QAA...
 Room unit QAA...

Attention: Extension module 3 is inside the heat pump

Control connection options

1 ControlBox

ControlBox, with two built-in extension modules, enables numerous options for application control on the consumer side behind the heat pump. For more, see the ControlBox schematic and the application diagrams sheet.

2 Fix flow temperature setpoint - On / Off dry (potential free) contact

2 wire shielded cable 2 x 0.5 mm² - Setpoint = 45°C (editable by param. 1859)

Connection terminal - see wiring diagram

3 Analog 0..10V flow temperature setpoint control

2 wire shielded cable 2 x 0.5 mm² - Setpoint: 0V = 16°C ~ 10V = 60°C (editable in parameter set)

Connection terminal - see wiring diagram

4 ModBus RTU communication command

3 wire shielded cable min. 3 x 0.25mm²

For ModBus mapping table contact technical support

5 MQTT IoT communication protocol

For more information contact technical support