

## Basic performance data - WAMAK TWW 600 EVI HeavyDuty 2L5

Heating - EN 14511		
Heating capacity [kW]	W10 / W35 (max)	619.7 ( 62.0 / 619.7 )
	W10 / W35 (min)	62.0 ( 62.0 / 619.7 )
	W10 / W34	619.9 ( 62.0 / 619.9 )
Electrical power input [kW]	W10 / W35 (max)	108.6 ( 10.6 / 108.6 )
	W10 / W35 (min)	10.6 ( 10.6 / 108.6 )
	W10 / W34	106.3 ( 15.1 / 154.8 )
Heating efficiency faktor [COP]	W10 / W35 (max)	5.71
	W10 / W35 (min)	5.85
	W10 / W34	5.83
Seasonal space heating energy efficiency - SCOP EN 14825		
Average Climate / Low Temperature [35°C]	SCOP	6.50
	$\eta$ [ % ]	259.8
	Label	A+++
	Qhe [ kWh ]	197045.2
	Pdesignh [ kW ]	619.7
	Tbivalent [ °C ]	-10
Cooling		
Cooling capacity - [kW]	A35 / W23-18	484.3
	A25 / W23-18	509.0
	A35 / W12-7	363.8
	A25 / W12-7	363.8
Seasonal space cooling energy efficiency - SEER EN 14825		
[ W 23 / 18°C ]	SEER	5.15
	Qce [ kWh ]	53383.3
	$\eta_c$ [ % ]	205.8
Sound EN 12102		
Acoustic power - Lw	dB(A)	77.3
Acoustic pressure - Lp	1 m dB(A)	69.3
	5 m dB(A)	55.3
	10 m dB(A)	49.3
Mechanical and operational information		
Compressor type (3~ 400/50)	SCROLL / 10 /	On/Off
Refrigerant	R410A (GWP - 2088)	5 x 11.5 kg
Operating limit temperatures heating - (min / max ) [°C]		25 / <b>65</b>
Operating limit temperatures source - (min / max ) [°C]		<b>-10 (7)</b> / 30
Weight		3100 kg

## Main technical data - WAMAK TWW 600 EVI HeavyDuty 2L5

Enclosure type		HD2L5		Heat energy rejection side data		
Basic dimensions	Height [mm]	2000		Operating limit temperatures heating	MAX [°C]	65
	Width [mm]	3450			MIN [°C]	25
	Length [mm]	1200		for more see operating limits diagram		
Weight [kg]	3100		Condenser	Port size	5 x VIC 2.1/2 "	
Colour	Gray			Type	BPHE	
Enclosure IP Class	IP20			Count	5	
Refrigeration cycle				Material	AISI 316	
Compressor	Type	Scroll		Maximal operating pressure - refrigerant [bar]		50
	Number of stages	10		Maximal operating pressure - Water [bar]		6
	On/Off			Testing pressure [bar]		70
	Power factor Cosφ	0.64		Heat transfer medium		Water
	Winding resistance	0.76 Ohm		Volume flow @ dT 5K (nom) - Water [m3/h]		10.71 ~ 107
Refrigerant		R410A		Internal pressure drop - Water [kPa]		5 x 20
	Volme	5 x 11.5 kg		Temperature difference	@ 35°C (nom)	5 K
	GWP	2088			@ 55°C	8 K
	Safety class	A1			@ 65°C	10 K
Refrigeration oil type	POE RL32-3MAF		Renewable energy extraction side data			
	Oil volume	10 x 3.38 L		Operating limit temperatures source	MIN [°C]	-10 (7)
Maximal pressure - refrigerant [bar]	50		for more see operating limits diagram			
	PED class	2		Evaporator	Port size	5 x VIC 2.1/2 "
EVI - vapour injection with economizer			Type		BPHE	
Electrical connection data			Count		5	
Line voltage [#~ V/Hz]	3~ 400/50		Material	AISI 316		
Current	nominal [A]	235.30		Maximal operating pressure - refrigerant [bar]		29
	maximal [A]	374.00		Heat transfer medium		Water
	starting [A]	57.2		Maximal operating pressure - Water [bar]		6
Softstart	-		Volume flow - Water [m3/h]		12.00 ~ 120	
Main safety	C400		Internal pressure drop - Water [kPa]		5 x 20	
Control System			Temperature difference - Water			4 K
Main controller	SIEMENS	RVS 61				
Extension module	AVS75.3xx	AVS75.3xx	AVS75.372			
Bus Clip-In		LPB OCI346	Modbus OCI352			
Online connection		Web server OZW672	ToSyMo			
Superheat controller			SEC61			

\*\*\* with accessory

## WAMAK TWW 600 EVI HeavyDuty 2L5

### ErP (EU) No 811/2013: Technical parameters for heat pump space heaters

Model	TWW 600 EVI HeavyDuty 2L5
Air-to-water heat pump	no
Brine-to-water heat pump	no
Water-to-water heat pump	yes
Low-temperature heat pump	no
Equipped with a supplementary heater	no
Heat pump combination heater	no
Temperature application	low (35°C - 30°C)
Climate conditions	average

Item	Symbol	Value	Unit	Item	Symbol	Value	Unit
Rated heat output at Tdesignh	Prated	619.7	kW	Seasonal space heating energy efficiency	$\eta_s$	259.8	%
Declared capacity for heating for part load at indoor temperature 20 °C and outdoor temperature Tj				Declared coefficient of performance or primary energy ratio for part load at indoor temperature 20 °C and outdoor temperature Tj			
Tj = -7 °C	Pdh	619.9	kW	Tj = -7 °C	COPd	5.83	-
Tj = +2 °C	Pdh	620.6	kW	Tj = +2 °C	COPd	6.4	-
Tj = +7 °C	Pdh	621.0	kW	Tj = +7 °C	COPd	6.9	-
Tj = +12 °C	Pdh	621.2	kW	Tj = +12 °C	COPd	7.4	-
Tj = bivalent temperature	Pdh	619.7	kW	Tj = bivalent temperature	COPd	5.7	-
Tj = operation limit temperature	Pdh	---	kW	Tj = operation limit temperature	COPd	---	-
Bivalent temperature	Tbiv	-10	°C	Tj = operation limit temperature	TOL	---	°C
Power consumption in modes other than active mode				Heating water operating limit temperature	WTOL	65	°C
Off mode	Poff	0.010	kW	Supplementary heater			
Thermostat-off mode	Pto	0.010	kW	Rated heat output	Psup	94.9	kW
Standby mode	Psb	0.010	kW	Type of energy input	electricity		
Crankcase heater mode	Pck	0.000	kW				
Other items				For air-to-water heat pumps: Rated air flow rate, outdoors	-	---	m <sup>3</sup> /h
Capacity control	multi-stage			For water- or brine-to-water heat pumps: Rated brine or water flow rate, outdoor heat exchanger	-	12.00 ~ 120	m <sup>3</sup> /h
Sound power level							
indoors	Lwa	77	dB				
outdoors	Lwa	---	dB				
Annual energy consumption	Q <sub>HE</sub>	197045.2	kWh				

**Contact details:** WAMAK, s.r.o., Orovnicna 252, 96652, Orovnicna, Slovakia, info@wamak.sk

## WAMAK TWW 600 EVI HeavyDuty 2L5

### ErP (EU) No 811/2013: Technical parameters for heat pump space heaters

Model	TWW 600 EVI HeavyDuty 2L5
Air-to-water heat pump	no
Brine-to-water heat pump	no
Water-to-water heat pump	yes
Low-temperature heat pump	no
Equipped with a supplementary heater	no
Heat pump combination heater	no
Temperature application	middle (55°C - 47°C)
Climate conditions	average

Item	Symbol	Value	Unit	Item	Symbol	Value	Unit
Rated heat output at Tdesignh	Prated	616.8	kW	Seasonal space heating energy efficiency	$\eta_s$	201.5	%
Declared capacity for heating for part load at indoor temperature 20 °C and outdoor temperature Tj				Declared coefficient of performance or primary energy ratio for part load at indoor temperature 20 °C and outdoor temperature Tj			
Tj = -7 °C	Pdh	623.2	kW	Tj = -7 °C	COPd	4.03	-
Tj = +2 °C	Pdh	625.4	kW	Tj = +2 °C	COPd	5.2	-
Tj = +7 °C	Pdh	626.8	kW	Tj = +7 °C	COPd	6.0	-
Tj = +12 °C	Pdh	627.9	kW	Tj = +12 °C	COPd	6.6	-
Tj = bivalent temperature	Pdh	616.8	kW	Tj = bivalent temperature	COPd	3.6	-
Tj = operation limit temperature	Pdh	---	kW	Tj = operation limit temperature	COPd	---	-
Bivalent temperature	Tbiv	-10	°C	Tj = operation limit temperature	TOL	---	°C
Power consumption in modes other than active mode				Heating water operating limit temperature	WTOL	65	°C
Off mode	Poff	0.010	kW	Supplementary heater			
Thermostat-off mode	Pto	0.010	kW	Rated heat output	Psup	94.9	kW
Standby mode	Psb	0.010	kW	Type of energy input	electricity		
Crankcase heater mode	Pck	0.000	kW	For air-to-water heat pumps:			
Other items				Rated air flow rate, outdoors	-	---	m <sup>3</sup> /h
Capacity control	multi-stage			For water- or brine-to-water heat pumps: Rated brine or water flow rate, outdoor heat exchanger			
Sound power level							
indoors	Lwa	77	dB				
outdoors	Lwa	---	dB				
Annual energy consumption	Q <sub>HE</sub>	252829.4	kWh				

**Contact details:** WAMAK, s.r.o., Orovnicna 252, 96652, Orovnicna, Slovakia, info@wamak.sk



**ENERG** Y IIA  
 енергия - ενεργεια IE IA



TWW 600 EVI  
 HeavyDuty 2L5



55 °C

35 °C



A+++

A+++



77 dB



--- dB

■ 648  
 ■ 617  
 ■ 605  
 kW

■ 633  
 ■ 620  
 ■ 589  
 kW



2019

811/2013

TWW 600 EVI  
 HeavyDuty 2L5

**ErP Data**

	55 °C	35 °C
Energy class	A+++	A+++
$\eta$ [%]	201.5	259.8
$P_{rated}$ [kW]	617	620
$Q_{HE}$ [kWh/y]	252830	197046
SCOP [-]	5.04	6.50
$T_{bivalent}$ [°C]	-10	-10

CONTROLLER



+ QAA55/75 class VII 3.5% ↓  
 - QAA55/75 class III 1.5% ↓

Heating performance data

Version: v2024.010-BW-WW

Source - Brine [0°C] / Low Temperature [35°C]

ZHI46K1P-TWD\_R410A\_10\_BWW

Operating conditions		Qh	P	COP
1	B0 / W30-35	492.1	108.6	4.53
2	B0 / W30-35 ( MIN )	49.2	10.6	4.65
A	B0 / Wxx-34	491.6	106.2	4.63
B	B0 / Wxx-30	489.2	97.1	5.04
C	B0 / Wxx-27	48.7	8.8	5.51
D	B0 / Wxx-24	48.5	8.2	5.88
E	B0 / Wxx-35	492.1	108.6	4.53
F	B0 / Wxx-35	492.1	108.6	4.53

SCOP DATA EN 14825:2018	
Source - Brine [0°C] / Low Temperature [35°C]	
SCOPon	5.15
SCOPnet	5.15
SCOP	5.15
η [ % ]	206.12
Label	A+++
Qh [ kWh ]	197221
Pdesignh [ kW ]	492.1
Tbivalent [ °C ]	-10

Source - Brine [0°C] / Medium Temperature [55°C]

Operating conditions		Qh	P	COP
1	B0 / W47-55	502.0	170.2	2.95
2	B0 / W47-55 ( MIN )	50.2	16.6	3.02
A	B0 / Wxx-52	505.3	155.3	3.36
B	B0 / Wxx-42	506.1	121.2	4.22
C	B0 / Wxx-36	49.8	10.5	4.75
D	B0 / Wxx-30	49.5	9.5	5.23
E	B0 / Wxx-55	502.0	170.2	2.95
F	B0 / Wxx-54	505.8	158.9	3.18

SCOP DATA EN 14825:2018	
Source - Brine [0°C] / Medium Temperature [55°C]	
SCOPon	4.11
SCOPnet	4.11
SCOP	4.11
η [ % ]	164.57
Label	A+++
Qh [ kWh ]	252004
Pdesignh [ kW ]	502.0
Tbivalent [ °C ]	-10

Source - Water [10°C] / Low Temperature [35°C]

Operating conditions		Qh	P	COP
1	W10 / W30-35	619.7	108.6	5.71
2	W10 / W30-35 ( MIN )	62.0	10.6	5.85
A	W10 / Wxx-34	619.9	106.3	5.83
B	W10 / Wxx-30	620.6	97.7	6.35
C	W10 / Wxx-27	621.0	91.7	6.94
D	W10 / Wxx-24	621.2	86.1	7.40
E	W10 / Wxx-35	619.7	108.6	5.71
F	W10 / Wxx-35	619.7	108.6	5.71

SCOP DATA EN 14825:2018	
Source - Water [10°C] / Low Temperature [35°C]	
SCOPon	6.50
SCOPnet	6.50
SCOP	6.50
η [ % ]	259.80
Label	A+++
Qh [ kWh ]	197045
Pdesignh [ kW ]	619.7
Tbivalent [ °C ]	-10.00

## WAMAK TWW 600 EVI HeavyDuty 2L5

### Source - Water [10°C] / Medium Temperature [55°C]

	Operating conditions	Qh	P	COP
1	W10 / W47-55	616.8	170.1	3.63
2	W10 / W47-55 ( MIN )	61.7	16.6	3.72
A	W10 / Wxx-52	623.2	154.8	4.03
B	W10 / Wxx-42	625.4	120.9	5.17
C	W10 / Wxx-36	626.8	107.4	5.98
D	W10 / Wxx-30	627.9	97.7	6.58
E	W10 / Wxx-55	616.8	170.1	3.63
F	W10 / Wxx-55	616.8	170.1	3.63

SCOP DATA EN 14825:2018	
Source - Water [10°C] / Medium Temperature [55°C]	
SCOPon	5.04
SCOPnet	5.04
SCOP	5.04
η [ % ]	201.54
Label	A+++
Qh [ kWh ]	252829
Pdesignh [ kW ]	616.8
Tbivalent [ °C ]	-10.00

### Low temperature cooling W 12 / 7°C

	Operating conditions	Qc	P	EER
A	W30-35 / W12-7	373.9	116.0	3.22
B	W26-xx / W12-7	380.8	106.2	3.59
C	W22-xx / W12-7	386.7	97.1	3.98
D	W18-xx / W12-7	389.3	92.8	4.20

SEER DATA EN 14825:2018 [ W 12 / 7°C ]	
SEERon	3.86
SEER	3.86
Qc [ kWh ]	218280
η [ % ]	154.51

### Radiant cooling W 23 / 18°C

	Operating conditions	Qc	P	EER
A	W50-xx / W23-18	434.4	182.4	2.38
B	W40-xx / W23-18	469.4	145.0	3.24
C	W30-35 / W23-18	497.4	116.0	4.29
D	W26-xx / W23-18	506.8	106.2	4.77

SEER DATA EN 14825:2018 [ W 23 / 18°C ]	
SEERon	5.15
SEER	5.15
Qc [ kWh ]	218280
η [ % ]	205.82

Performance lines - heating

- Qh-nom-35    - - - Qh-min-35    - - - - - Qh-max-65    — Qh-nom-45    — Qh-nom-55
- Qh-nom-65

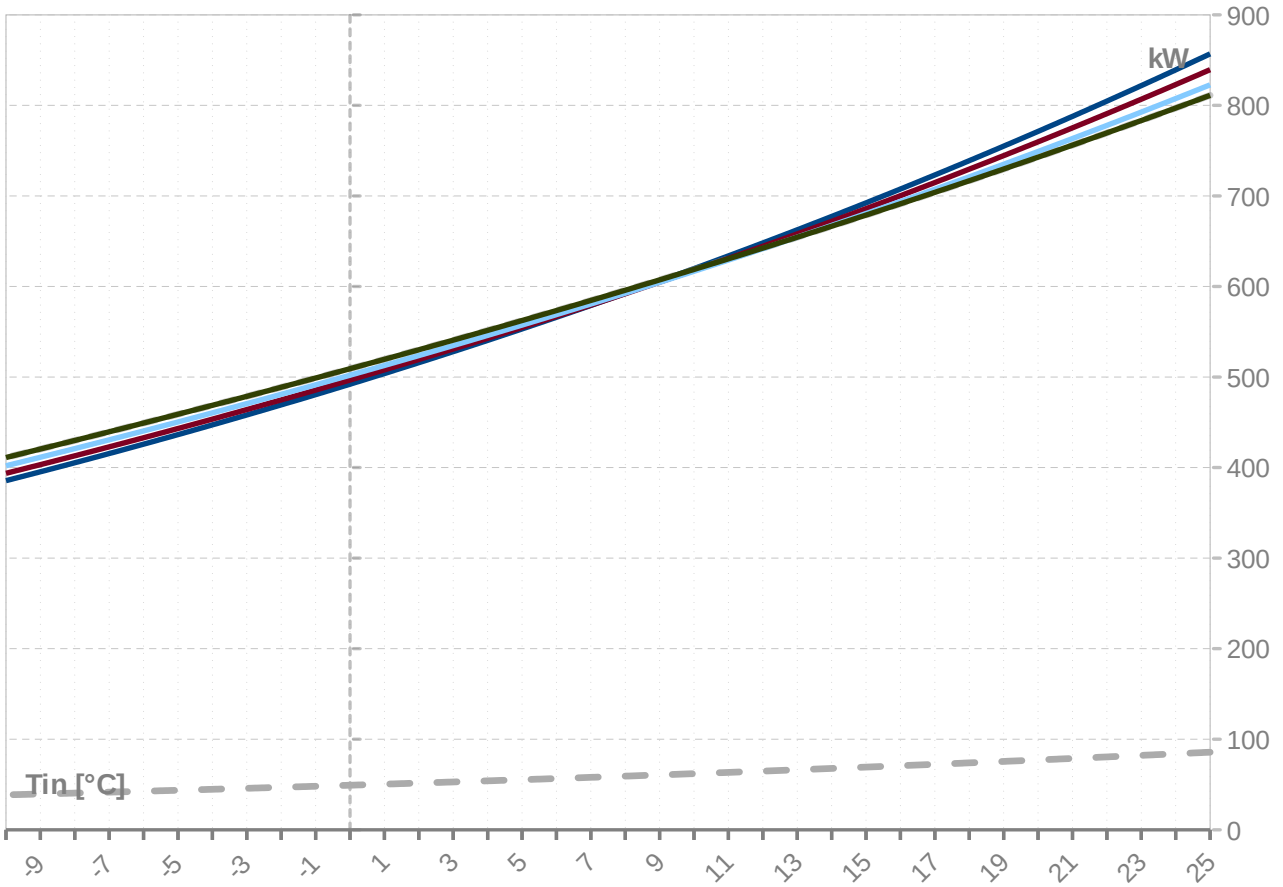

Performance lines - cooling

- Qc-nom-12-7    — Qc-nom-23-18

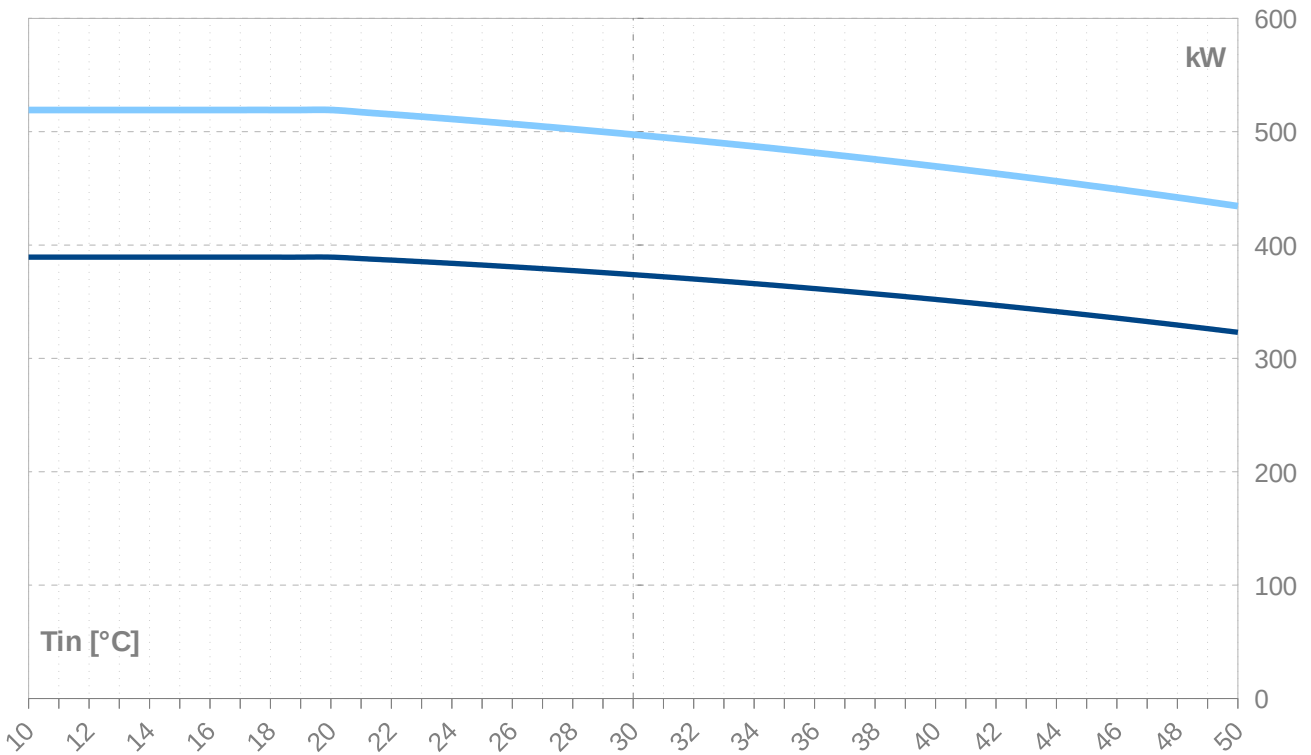



# WAMAK TWW 600 EVI HeavyDuty 2L5

Th -OU	35										
Ts -IN [°C]	Qh nom [kW]	Qh min [kW]	Qh max [kW]	Pin nom [kW]	Pin min [kW]	Pin max [kW]	COP nom kW / kW	Qc nom [kW]	Qc min [kW]	Qc max [kW]	I nom [A]
25	<b>856.9</b>	85.7	856.9	<b>110.9</b>	10.8	110.9	<b>7.73</b>	753.3	75.3	753.3	234.5
24	<b>839.2</b>	83.9	839.2	<b>110.6</b>	10.8	110.6	<b>7.59</b>	735.9	73.6	735.9	234.0
23	<b>821.8</b>	82.2	821.8	<b>110.3</b>	10.8	110.3	<b>7.45</b>	718.8	71.9	718.8	233.6
22	<b>804.7</b>	80.5	804.7	<b>110.0</b>	10.7	110.0	<b>7.31</b>	701.9	70.2	701.9	233.2
21	<b>787.8</b>	78.8	787.8	<b>109.8</b>	10.7	109.8	<b>7.18</b>	685.3	68.5	685.3	232.9
20	<b>771.3</b>	77.1	771.3	<b>109.6</b>	10.7	109.6	<b>7.04</b>	668.9	66.9	668.9	232.7
19	<b>755.0</b>	75.5	755.0	<b>109.4</b>	10.7	109.4	<b>6.90</b>	652.8	65.3	652.8	232.5
18	<b>738.9</b>	73.9	738.9	<b>109.2</b>	10.7	109.2	<b>6.76</b>	636.9	63.7	636.9	232.4
17	<b>723.1</b>	72.3	723.1	<b>109.1</b>	10.6	109.1	<b>6.63</b>	621.3	62.1	621.3	232.3
16	<b>707.6</b>	70.8	707.6	<b>109.0</b>	10.6	109.0	<b>6.49</b>	605.8	60.6	605.8	232.3
15	<b>692.3</b>	69.2	692.3	<b>108.9</b>	10.6	108.9	<b>6.36</b>	590.7	59.1	590.7	232.4
14	<b>677.3</b>	67.7	677.3	<b>108.8</b>	10.6	108.8	<b>6.23</b>	575.7	57.6	575.7	232.4
13	<b>662.6</b>	66.3	662.6	<b>108.7</b>	10.6	108.7	<b>6.10</b>	561.0	56.1	561.0	232.5
12	<b>648.0</b>	64.8	648.0	<b>108.6</b>	10.6	108.6	<b>5.96</b>	546.6	54.7	546.6	232.7
11	<b>633.8</b>	63.4	633.8	<b>108.6</b>	10.6	108.6	<b>5.84</b>	532.4	53.2	532.4	232.8
10	<b>619.7</b>	62.0	619.7	<b>108.6</b>	10.6	108.6	<b>5.71</b>	518.4	51.8	518.4	233.0
9	<b>605.9</b>	60.6	605.9	<b>108.5</b>	10.6	108.5	<b>5.58</b>	504.6	50.5	504.6	233.2
8	<b>592.4</b>	59.2	592.4	<b>108.5</b>	10.6	108.5	<b>5.46</b>	491.0	49.1	491.0	233.5
7	<b>579.1</b>	57.9	579.1	<b>108.5</b>	10.6	108.5	<b>5.34</b>	477.7	47.8	477.7	233.7
6	<b>566.0</b>	56.6	566.0	<b>108.5</b>	10.6	108.5	<b>5.22</b>	464.6	46.5	464.6	234.0
5	<b>553.1</b>	55.3	553.1	<b>108.5</b>	10.6	108.5	<b>5.10</b>	451.8	45.2	451.8	234.3
4	<b>540.5</b>	54.0	540.5	<b>108.5</b>	10.6	108.5	<b>4.98</b>	439.1	43.9	439.1	234.6
3	<b>528.1</b>	52.8	528.1	<b>108.5</b>	10.6	108.5	<b>4.87</b>	426.7	42.7	426.7	234.9
2	<b>515.9</b>	51.6	515.9	<b>108.5</b>	10.6	108.5	<b>4.75</b>	414.5	41.4	414.5	235.1
1	<b>503.9</b>	50.4	503.9	<b>108.6</b>	10.6	108.6	<b>4.64</b>	402.5	40.3	402.5	235.4
0	<b>492.1</b>	49.2	492.1	<b>108.6</b>	10.6	108.6	<b>4.53</b>	390.7	39.1	390.7	235.7
-1	<b>480.5</b>	48.1	480.5	<b>108.6</b>	10.6	108.6	<b>4.43</b>	379.2	37.9	379.2	236.0
-2	<b>469.2</b>	46.9	469.2	<b>108.6</b>	10.6	108.6	<b>4.32</b>	367.8	36.8	367.8	236.3
-3	<b>458.0</b>	45.8	458.0	<b>108.5</b>	10.6	108.5	<b>4.22</b>	356.7	35.7	356.7	236.5
-4	<b>447.1</b>	44.7	447.1	<b>108.5</b>	10.6	108.5	<b>4.12</b>	345.8	34.6	345.8	236.7
-5	<b>436.4</b>	43.6	436.4	<b>108.5</b>	10.6	108.5	<b>4.02</b>	335.0	33.5	335.0	236.9
-6	<b>425.8</b>	42.6	425.8	<b>108.5</b>	10.6	108.5	<b>3.93</b>	324.5	32.5	324.5	237.1
-7	<b>415.4</b>	41.5	415.4	<b>108.4</b>	10.6	108.4	<b>3.83</b>	314.2	31.4	314.2	237.3
-8	<b>405.3</b>	40.5	405.3	<b>108.4</b>	10.6	108.4	<b>3.74</b>	304.1	30.4	304.1	237.4
-9	<b>395.3</b>	39.5	395.3	<b>108.3</b>	10.6	108.3	<b>3.65</b>	294.2	29.4	294.2	237.4
-10	<b>385.5</b>	38.6	385.5	<b>108.2</b>	10.6	108.2	<b>3.56</b>	284.5	28.4	284.5	237.5
-11	<b>375.9</b>	37.6	375.9	<b>108.1</b>	10.5	108.1	<b>3.48</b>	275.0	27.5	275.0	237.5
-12	<b>366.5</b>	36.6	366.5	<b>108.0</b>	10.5	108.0	<b>3.39</b>	265.7	26.6	265.7	237.4
-13	<b>357.2</b>	35.7	357.2	<b>107.8</b>	10.5	107.8	<b>3.31</b>	256.5	25.7	256.5	237.3
-14	<b>348.1</b>	34.8	348.1	<b>107.6</b>	10.5	107.6	<b>3.23</b>	247.6	24.8	247.6	237.2
-15	<b>339.2</b>	33.9	339.2	<b>107.4</b>	10.5	107.4	<b>3.16</b>	238.9	23.9	238.9	237.0

-- attention: operating limits not reflected in performance table

ZHI46K1P-TWD\_R410A\_10\_BWW

Th -OU	45										
[°C]	Qh nom [kW]	Qh min [kW]	Qh max [kW]	Pin nom [kW]	Pin min [kW]	Pin max [kW]	COP nom kW / kW	Qc nom [kW]	Qc min [kW]	Qc max [kW]	I nom [A]
25	839.4	83.9	839.4	133.3	13.0	133.3	6.30	714.9	71.5	714.9	264.7
24	823.0	82.3	823.0	133.2	13.0	133.2	6.18	698.5	69.9	698.5	264.4
23	806.8	80.7	806.8	133.2	13.0	133.2	6.06	682.4	68.2	682.4	264.1
22	790.8	79.1	790.8	133.1	13.0	133.1	5.94	666.5	66.7	666.5	263.9
21	775.2	77.5	775.2	133.1	13.0	133.1	5.82	650.9	65.1	650.9	263.7
20	759.7	76.0	759.7	133.1	13.0	133.1	5.71	635.4	63.5	635.4	263.6
19	744.5	74.4	744.5	133.1	13.0	133.1	5.59	620.2	62.0	620.2	263.5
18	729.5	73.0	729.5	133.1	13.0	133.1	5.48	605.2	60.5	605.2	263.4
17	714.8	71.5	714.8	133.1	13.0	133.1	5.37	590.4	59.0	590.4	263.4
16	700.2	70.0	700.2	133.2	13.0	133.2	5.26	575.9	57.6	575.9	263.4
15	686.0	68.6	686.0	133.2	13.0	133.2	5.15	561.5	56.2	561.5	263.4
14	671.9	67.2	671.9	133.3	13.0	133.3	5.04	547.4	54.7	547.4	263.5
13	658.0	65.8	658.0	133.3	13.0	133.3	4.94	533.5	53.4	533.5	263.6
12	644.4	64.4	644.4	133.4	13.0	133.4	4.83	519.8	52.0	519.8	263.7
11	631.0	63.1	631.0	133.5	13.0	133.5	4.73	506.3	50.6	506.3	263.8
10	617.8	61.8	617.8	133.5	13.0	133.5	4.63	493.1	49.3	493.1	263.9
9	604.8	60.5	604.8	133.6	13.0	133.6	4.53	480.0	48.0	480.0	264.0
8	592.0	59.2	592.0	133.7	13.0	133.7	4.43	467.1	46.7	467.1	264.1
7	579.4	57.9	579.4	133.7	13.0	133.7	4.33	454.5	45.4	454.5	264.2
6	567.0	56.7	567.0	133.8	13.1	133.8	4.24	442.0	44.2	442.0	264.4
5	554.8	55.5	554.8	133.9	13.1	133.9	4.14	429.8	43.0	429.8	264.5
4	542.8	54.3	542.8	133.9	13.1	133.9	4.05	417.7	41.8	417.7	264.6
3	531.0	53.1	531.0	134.0	13.1	134.0	3.96	405.9	40.6	405.9	264.7
2	519.4	51.9	519.4	134.0	13.1	134.0	3.88	394.2	39.4	394.2	264.7
1	507.9	50.8	507.9	134.0	13.1	134.0	3.79	382.8	38.3	382.8	264.8
0	496.7	49.7	496.7	134.0	13.1	134.0	3.71	371.5	37.2	371.5	264.8
-1	485.6	48.6	485.6	134.0	13.1	134.0	3.62	360.5	36.0	360.5	264.8
-2	474.7	47.5	474.7	134.0	13.1	134.0	3.54	349.6	35.0	349.6	264.8
-3	464.0	46.4	464.0	134.0	13.1	134.0	3.46	338.9	33.9	338.9	264.7
-4	453.5	45.3	453.5	133.9	13.1	133.9	3.39	328.4	32.8	328.4	264.6
-5	443.1	44.3	443.1	133.9	13.1	133.9	3.31	318.1	31.8	318.1	264.5
-6	432.9	43.3	432.9	133.8	13.0	133.8	3.24	308.0	30.8	308.0	264.3
-7	422.8	42.3	422.8	133.7	13.0	133.7	3.16	298.0	29.8	298.0	264.1
-8	412.9	41.3	412.9	133.5	13.0	133.5	3.09	288.2	28.8	288.2	263.8
-9	403.2	40.3	403.2	133.4	13.0	133.4	3.02	278.7	27.9	278.7	263.4
-10	393.6	39.4	393.6	133.2	13.0	133.2	2.96	269.2	26.9	269.2	263.0
-11	384.2	38.4	384.2	133.0	13.0	133.0	2.89	260.0	26.0	260.0	262.6
-12	374.9	37.5	374.9	132.7	12.9	132.7	2.82	251.0	25.1	251.0	262.1
-13	365.8	36.6	365.8	132.5	12.9	132.5	2.76	242.1	24.2	242.1	261.5
-14	356.8	35.7	356.8	132.2	12.9	132.2	2.70	233.4	23.3	233.4	260.8
-15	348.0	34.8	348.0	131.9	12.9	131.9	2.64	224.8	22.5	224.8	260.1

-- attention: operating limits not reflected in performance table

**WAMAK TWW 600 EVI HeavyDuty 2L5**

Th -OU		55										
Ts -IN	Qh nom	Qh min	Qh max	Pin nom	Pin min	Pin max	COP nom	Qc nom	Qc min	Qc max	I nom	
[°C]	[kW]	[kW]	[kW]	[kW]	[kW]	[kW]	kW / kW	[kW]	[kW]	[kW]	[A]	
25	<b>822.6</b>	82.3	822.6	<b>168.3</b>	16.4	168.3	<b>4.89</b>	665.4	66.5	665.4	306.5	
24	<b>807.5</b>	80.8	807.5	<b>168.4</b>	16.4	168.4	<b>4.79</b>	650.2	65.0	650.2	306.4	
23	<b>792.6</b>	79.3	792.6	<b>168.5</b>	16.4	168.5	<b>4.70</b>	635.2	63.5	635.2	306.4	
22	<b>777.9</b>	77.8	777.9	<b>168.6</b>	16.5	168.6	<b>4.61</b>	620.4	62.0	620.4	306.4	
21	<b>763.4</b>	76.3	763.4	<b>168.8</b>	16.5	168.8	<b>4.52</b>	605.8	60.6	605.8	306.4	
20	<b>749.0</b>	74.9	749.0	<b>168.9</b>	16.5	168.9	<b>4.44</b>	591.3	59.1	591.3	306.5	
19	<b>735.0</b>	73.5	735.0	<b>169.0</b>	16.5	169.0	<b>4.35</b>	577.1	57.7	577.1	306.5	
18	<b>721.1</b>	72.1	721.1	<b>169.1</b>	16.5	169.1	<b>4.26</b>	563.1	56.3	563.1	306.6	
17	<b>707.4</b>	70.7	707.4	<b>169.3</b>	16.5	169.3	<b>4.18</b>	549.3	54.9	549.3	306.7	
16	<b>693.9</b>	69.4	693.9	<b>169.4</b>	16.5	169.4	<b>4.10</b>	535.7	53.6	535.7	306.8	
15	<b>680.5</b>	68.1	680.5	<b>169.5</b>	16.5	169.5	<b>4.01</b>	522.2	52.2	522.2	306.9	
14	<b>667.4</b>	66.7	667.4	<b>169.6</b>	16.5	169.6	<b>3.93</b>	509.0	50.9	509.0	307.0	
13	<b>654.5</b>	65.4	654.5	<b>169.8</b>	16.6	169.8	<b>3.86</b>	496.0	49.6	496.0	307.2	
12	<b>641.7</b>	64.2	641.7	<b>169.9</b>	16.6	169.9	<b>3.78</b>	483.1	48.3	483.1	307.3	
11	<b>629.2</b>	62.9	629.2	<b>170.0</b>	16.6	170.0	<b>3.70</b>	470.4	47.0	470.4	307.4	
10	<b>616.8</b>	61.7	616.8	<b>170.1</b>	16.6	170.1	<b>3.63</b>	458.0	45.8	458.0	307.5	
9	<b>604.6</b>	60.5	604.6	<b>170.1</b>	16.6	170.1	<b>3.55</b>	445.7	44.6	445.7	307.6	
8	<b>592.5</b>	59.3	592.5	<b>170.2</b>	16.6	170.2	<b>3.48</b>	433.6	43.4	433.6	307.6	
7	<b>580.6</b>	58.1	580.6	<b>170.3</b>	16.6	170.3	<b>3.41</b>	421.6	42.2	421.6	307.7	
6	<b>568.9</b>	56.9	568.9	<b>170.3</b>	16.6	170.3	<b>3.34</b>	409.9	41.0	409.9	307.7	
5	<b>557.4</b>	55.7	557.4	<b>170.4</b>	16.6	170.4	<b>3.27</b>	398.3	39.8	398.3	307.7	
4	<b>546.0</b>	54.6	546.0	<b>170.4</b>	16.6	170.4	<b>3.20</b>	386.9	38.7	386.9	307.7	
3	<b>534.8</b>	53.5	534.8	<b>170.4</b>	16.6	170.4	<b>3.14</b>	375.7	37.6	375.7	307.6	
2	<b>523.7</b>	52.4	523.7	<b>170.3</b>	16.6	170.3	<b>3.07</b>	364.6	36.5	364.6	307.5	
1	<b>512.8</b>	51.3	512.8	<b>170.3</b>	16.6	170.3	<b>3.01</b>	353.8	35.4	353.8	307.4	
0	<b>502.0</b>	50.2	502.0	<b>170.2</b>	16.6	170.2	<b>2.95</b>	343.1	34.3	343.1	307.2	
-1	<b>491.4</b>	49.1	491.4	<b>170.1</b>	16.6	170.1	<b>2.89</b>	332.5	33.3	332.5	307.0	
-2	<b>480.9</b>	48.1	480.9	<b>170.0</b>	16.6	170.0	<b>2.83</b>	322.2	32.2	322.2	306.7	
-3	<b>470.6</b>	47.1	470.6	<b>169.9</b>	16.6	169.9	<b>2.77</b>	312.0	31.2	312.0	306.4	
-4	<b>460.4</b>	46.0	460.4	<b>169.7</b>	16.6	169.7	<b>2.71</b>	301.9	30.2	301.9	306.0	
-5	<b>450.3</b>	45.0	450.3	<b>169.5</b>	16.5	169.5	<b>2.66</b>	292.1	29.2	292.1	305.6	
-6	<b>440.4</b>	44.0	440.4	<b>169.3</b>	16.5	169.3	<b>2.60</b>	282.3	28.2	282.3	305.1	
-7	<b>430.6</b>	43.1	430.6	<b>169.0</b>	16.5	169.0	<b>2.55</b>	272.8	27.3	272.8	304.5	
-8	<b>420.9</b>	42.1	420.9	<b>168.7</b>	16.5	168.7	<b>2.50</b>	263.4	26.3	263.4	303.8	
-9	<b>411.4</b>	41.1	411.4	<b>168.4</b>	16.4	168.4	<b>2.44</b>	254.2	25.4	254.2	303.1	
-10	<b>401.9</b>	40.2	401.9	<b>168.0</b>	16.4	168.0	<b>2.39</b>	245.1	24.5	245.1	302.3	
-11	<b>392.6</b>	39.3	392.6	<b>167.6</b>	16.3	167.6	<b>2.34</b>	236.1	23.6	236.1	301.4	
-12	<b>383.4</b>	38.3	383.4	<b>167.1</b>	16.3	167.1	<b>2.29</b>	227.4	22.7	227.4	300.5	
-13	<b>374.4</b>	37.4	374.4	<b>166.6</b>	16.3	166.6	<b>2.25</b>	218.7	21.9	218.7	299.4	
-14	<b>365.4</b>	36.5	365.4	<b>166.1</b>	16.2	166.1	<b>2.20</b>	210.3	21.0	210.3	298.3	
-15	<b>356.5</b>	35.7	356.5	<b>165.5</b>	16.1	165.5	<b>2.15</b>	201.9	20.2	201.9	297.1	

-- attention: operating limits not reflected in performance table

**WAMAK TWW 600 EVI HeavyDuty 2L5**

Th -OU	65 (T-max)										
[°C]	Qh nom [kW]	Qh min [kW]	Qh max [kW]	Pin nom [kW]	Pin min [kW]	Pin max [kW]	COP nom kW / kW	Qc nom [kW]	Qc min [kW]	Qc max [kW]	I nom [A]
25	<b>811.1</b>	81.1	811.1	<b>214.5</b>	20.9	214.5	<b>3.78</b>	610.8	61.1	610.8	359.7
24	<b>797.1</b>	79.7	797.1	<b>214.7</b>	20.9	214.7	<b>3.71</b>	596.6	59.7	596.6	360.0
23	<b>783.2</b>	78.3	783.2	<b>214.8</b>	21.0	214.8	<b>3.65</b>	582.6	58.3	582.6	360.2
22	<b>769.6</b>	77.0	769.6	<b>215.0</b>	21.0	215.0	<b>3.58</b>	568.8	56.9	568.8	360.5
21	<b>756.1</b>	75.6	756.1	<b>215.2</b>	21.0	215.2	<b>3.51</b>	555.2	55.5	555.2	360.8
20	<b>742.8</b>	74.3	742.8	<b>215.3</b>	21.0	215.3	<b>3.45</b>	541.7	54.2	541.7	361.1
19	<b>729.7</b>	73.0	729.7	<b>215.5</b>	21.0	215.5	<b>3.39</b>	528.5	52.8	528.5	361.4
18	<b>716.7</b>	71.7	716.7	<b>215.6</b>	21.0	215.6	<b>3.32</b>	515.4	51.5	515.4	361.7
17	<b>703.9</b>	70.4	703.9	<b>215.8</b>	21.0	215.8	<b>3.26</b>	502.5	50.2	502.5	362.0
16	<b>691.3</b>	69.1	691.3	<b>215.9</b>	21.1	215.9	<b>3.20</b>	489.7	49.0	489.7	362.2
15	<b>678.8</b>	67.9	678.8	<b>216.0</b>	21.1	216.0	<b>3.14</b>	477.1	47.7	477.1	362.5
14	<b>666.5</b>	66.7	666.5	<b>216.1</b>	21.1	216.1	<b>3.08</b>	464.7	46.5	464.7	362.8
13	<b>654.4</b>	65.4	654.4	<b>216.2</b>	21.1	216.2	<b>3.03</b>	452.5	45.3	452.5	363.0
12	<b>642.4</b>	64.2	642.4	<b>216.3</b>	21.1	216.3	<b>2.97</b>	440.4	44.0	440.4	363.2
11	<b>630.5</b>	63.1	630.5	<b>216.3</b>	21.1	216.3	<b>2.92</b>	428.5	42.9	428.5	363.4
10	<b>618.8</b>	61.9	618.8	<b>216.3</b>	21.1	216.3	<b>2.86</b>	416.8	41.7	416.8	363.6
9	<b>607.3</b>	60.7	607.3	<b>216.3</b>	21.1	216.3	<b>2.81</b>	405.2	40.5	405.2	363.7
8	<b>595.8</b>	59.6	595.8	<b>216.3</b>	21.1	216.3	<b>2.75</b>	393.8	39.4	393.8	363.8
7	<b>584.6</b>	58.5	584.6	<b>216.3</b>	21.1	216.3	<b>2.70</b>	382.6	38.3	382.6	363.8
6	<b>573.4</b>	57.3	573.4	<b>216.2</b>	21.1	216.2	<b>2.65</b>	371.5	37.1	371.5	363.9
5	<b>562.4</b>	56.2	562.4	<b>216.2</b>	21.1	216.2	<b>2.60</b>	360.5	36.1	360.5	363.8
4	<b>551.5</b>	55.2	551.5	<b>216.0</b>	21.1	216.0	<b>2.55</b>	349.8	35.0	349.8	363.8
3	<b>540.7</b>	54.1	540.7	<b>215.9</b>	21.1	215.9	<b>2.50</b>	339.1	33.9	339.1	363.6
2	<b>530.1</b>	53.0	530.1	<b>215.7</b>	21.0	215.7	<b>2.46</b>	328.6	32.9	328.6	363.4
1	<b>519.6</b>	52.0	519.6	<b>215.5</b>	21.0	215.5	<b>2.41</b>	318.3	31.8	318.3	363.2
0	<b>509.2</b>	50.9	509.2	<b>215.3</b>	21.0	215.3	<b>2.37</b>	308.1	30.8	308.1	362.9
-1	<b>498.9</b>	49.9	498.9	<b>215.0</b>	21.0	215.0	<b>2.32</b>	298.1	29.8	298.1	362.5
-2	<b>488.7</b>	48.9	488.7	<b>214.7</b>	20.9	214.7	<b>2.28</b>	288.2	28.8	288.2	362.1
-3	<b>478.7</b>	47.9	478.7	<b>214.4</b>	20.9	214.4	<b>2.23</b>	278.5	27.8	278.5	361.6
-4	<b>468.7</b>	46.9	468.7	<b>214.0</b>	20.9	214.0	<b>2.19</b>	268.9	26.9	268.9	361.0
-5	<b>458.9</b>	45.9	458.9	<b>213.6</b>	20.8	213.6	<b>2.15</b>	259.4	25.9	259.4	360.3
-6	<b>449.1</b>	44.9	449.1	<b>213.1</b>	20.8	213.1	<b>2.11</b>	250.1	25.0	250.1	359.6
-7	<b>439.5</b>	43.9	439.5	<b>212.6</b>	20.7	212.6	<b>2.07</b>	240.9	24.1	240.9	358.8
-8	<b>429.9</b>	43.0	429.9	<b>212.1</b>	20.7	212.1	<b>2.03</b>	231.8	23.2	231.8	357.9
-9	<b>420.4</b>	42.0	420.4	<b>211.5</b>	20.6	211.5	<b>1.99</b>	222.9	22.3	222.9	356.9
-10	<b>411.1</b>	41.1	411.1	<b>210.9</b>	20.6	210.9	<b>1.95</b>	214.1	21.4	214.1	355.8
-11	<b>401.8</b>	40.2	401.8	<b>210.2</b>	20.5	210.2	<b>1.91</b>	205.5	20.5	205.5	354.6
-12	<b>392.6</b>	39.3	392.6	<b>209.4</b>	20.4	209.4	<b>1.87</b>	197.0	19.7	197.0	353.2
-13	<b>383.4</b>	38.3	383.4	<b>208.7</b>	20.4	208.7	<b>1.84</b>	188.6	18.9	188.6	351.8
-14	<b>374.4</b>	37.4	374.4	<b>207.8</b>	20.3	207.8	<b>1.80</b>	180.3	18.0	180.3	350.3
-15	<b>365.4</b>	36.5	365.4	<b>206.9</b>	20.2	206.9	<b>1.77</b>	172.2	17.2	172.2	348.7

-- attention: operating limits not reflected in performance table

# WAMAK TWW 600 EVI HeavyDuty 2L5

Tc -OU		W 12 / 7 °C										
Ts -IN	Qc nom	Qc min	Qc max	Pin nom	Pin min	Pin max	EER	Qh nom	Qh min	Qh max	I nom	
[°C]	[kW]	[kW]	[kW]	[kW]	[kW]	[kW]	kW / kW	[kW]	[kW]	[kW]	[A]	
40	<b>352.0</b>	35.2	352.0	<b>145.0</b>	14.1	145.0	<b>2.43</b>	487.4	48.7	487.4	277.4	
39	<b>354.5</b>	35.5	354.5	<b>141.8</b>	13.8	141.8	<b>2.50</b>	486.9	48.7	486.9	273.7	
38	<b>357.0</b>	35.7	357.0	<b>138.6</b>	13.5	138.6	<b>2.58</b>	486.4	48.6	486.4	270.0	
37	<b>359.3</b>	35.9	359.3	<b>135.5</b>	13.2	135.5	<b>2.65</b>	485.9	48.6	485.9	266.5	
36	<b>361.6</b>	36.2	361.6	<b>132.5</b>	12.9	132.5	<b>2.73</b>	485.4	48.5	485.4	263.1	
35	<b>363.8</b>	36.4	363.8	<b>129.6</b>	12.6	129.6	<b>2.81</b>	484.9	48.5	484.9	259.8	
34	<b>366.0</b>	36.6	366.0	<b>126.8</b>	12.4	126.8	<b>2.89</b>	484.3	48.4	484.3	256.6	
33	<b>368.0</b>	36.8	368.0	<b>124.0</b>	12.1	124.0	<b>2.97</b>	483.8	48.4	483.8	253.4	
32	<b>370.1</b>	37.0	370.1	<b>121.3</b>	11.8	121.3	<b>3.05</b>	483.3	48.3	483.3	250.3	
31	<b>372.0</b>	37.2	372.0	<b>118.6</b>	11.6	118.6	<b>3.14</b>	482.8	48.3	482.8	247.3	
30	<b>373.9</b>	37.4	373.9	<b>116.0</b>	11.3	116.0	<b>3.22</b>	482.2	48.2	482.2	244.4	
29	<b>375.7</b>	37.6	375.7	<b>113.5</b>	11.1	113.5	<b>3.31</b>	481.7	48.2	481.7	241.6	
28	<b>377.5</b>	37.7	377.5	<b>111.0</b>	10.8	111.0	<b>3.40</b>	481.1	48.1	481.1	238.7	
27	<b>379.2</b>	37.9	379.2	<b>108.6</b>	10.6	108.6	<b>3.49</b>	480.5	48.1	480.5	236.0	
26	<b>380.8</b>	38.1	380.8	<b>106.2</b>	10.4	106.2	<b>3.59</b>	480.0	48.0	480.0	233.3	
25	<b>382.4</b>	38.2	382.4	<b>103.8</b>	10.1	103.8	<b>3.68</b>	479.3	47.9	479.3	230.6	
24	<b>383.9</b>	38.4	383.9	<b>101.5</b>	9.9	101.5	<b>3.78</b>	478.7	47.9	478.7	228.0	
23	<b>385.3</b>	38.5	385.3	<b>99.3</b>	9.7	99.3	<b>3.88</b>	478.1	47.8	478.1	225.4	
22	<b>386.7</b>	38.7	386.7	<b>97.1</b>	9.5	97.1	<b>3.98</b>	477.4	47.7	477.4	222.8	
21	<b>388.1</b>	38.8	388.1	<b>94.9</b>	9.3	94.9	<b>4.09</b>	476.7	47.7	476.7	220.3	
20	<b>389.3</b>	38.9	389.3	<b>92.8</b>	9.0	92.8	<b>4.20</b>	476.0	47.6	476.0	217.8	

Tc [°C]		W 23 / 18 °C										
0	Qc nom	Qc min	Qc max	Pin nom	Pin min	Pin max	EER	Qh nom	Qh min	Qh max	I nom	
[°C]	[kW]	[kW]	[kW]	[kW]	[kW]	[kW]	kW / kW	[kW]	[kW]	[kW]	[A]	
40	<b>469.4</b>	46.9	469.4	<b>145.0</b>	14.1	145.0	<b>3.24</b>	604.5	60.4	605.0	277.1	
39	<b>472.5</b>	47.3	472.5	<b>141.8</b>	13.8	141.8	<b>3.33</b>	604.5	60.5	604.8	273.3	
38	<b>475.6</b>	47.6	475.6	<b>138.6</b>	13.5	138.6	<b>3.43</b>	604.6	60.5	604.7	269.5	
37	<b>478.5</b>	47.9	478.5	<b>135.5</b>	13.2	135.5	<b>3.53</b>	604.7	60.5	604.6	265.8	
36	<b>481.4</b>	48.1	481.4	<b>132.5</b>	12.9	132.5	<b>3.63</b>	604.8	60.5	604.5	262.2	
35	<b>484.3</b>	48.4	484.3	<b>129.6</b>	12.6	129.6	<b>3.74</b>	604.9	60.5	604.4	258.7	
34	<b>487.0</b>	48.7	487.0	<b>126.8</b>	12.4	126.8	<b>3.84</b>	605.1	60.5	604.4	255.3	
33	<b>489.7</b>	49.0	489.7	<b>124.0</b>	12.1	124.0	<b>3.95</b>	605.2	60.5	604.4	252.0	
32	<b>492.4</b>	49.2	492.4	<b>121.3</b>	11.8	121.3	<b>4.06</b>	605.3	60.5	604.4	248.7	
31	<b>494.9</b>	49.5	494.9	<b>118.6</b>	11.6	118.6	<b>4.17</b>	605.4	60.5	604.4	245.5	
30	<b>497.4</b>	49.7	497.4	<b>116.0</b>	11.3	116.0	<b>4.29</b>	605.6	60.6	604.5	242.3	
29	<b>499.9</b>	50.0	499.9	<b>113.5</b>	11.1	113.5	<b>4.41</b>	605.7	60.6	604.5	239.3	
28	<b>502.3</b>	50.2	502.3	<b>111.0</b>	10.8	111.0	<b>4.53</b>	605.8	60.6	604.6	236.2	
27	<b>504.6</b>	50.5	504.6	<b>108.6</b>	10.6	108.6	<b>4.65</b>	605.9	60.6	604.7	233.2	
26	<b>506.8</b>	50.7	506.8	<b>106.2</b>	10.4	106.2	<b>4.77</b>	606.1	60.6	604.8	230.3	
25	<b>509.0</b>	50.9	509.0	<b>103.8</b>	10.1	103.8	<b>4.90</b>	606.2	60.6	604.9	227.4	
24	<b>511.2</b>	51.1	511.2	<b>101.5</b>	9.9	101.5	<b>5.03</b>	606.3	60.6	605.1	224.5	
23	<b>513.3</b>	51.3	513.3	<b>99.3</b>	9.7	99.3	<b>5.17</b>	606.3	60.6	605.2	221.6	
22	<b>515.3</b>	51.5	515.3	<b>97.1</b>	9.5	97.1	<b>5.31</b>	606.4	60.6	605.3	218.8	
21	<b>517.2</b>	51.7	517.2	<b>94.9</b>	9.3	94.9	<b>5.45</b>	606.4	60.6	605.4	216.0	
20	<b>519.1</b>	51.9	519.1	<b>92.8</b>	9.0	92.8	<b>5.60</b>	606.5	60.6	605.6	213.2	

-- attention: operating limits not reflected in performance table

LEGEND:

Ts-IN: Temperature renewable source - inlet [°C]  
Th-OU: Temperature heating - outlet (flow) [°C]  
Tc-OU: Temperature cooling - outlet (flow) [°C]  
Qh nom: Heating capacity nominal  
Qh min: Heating capacity minimal  
Qh max: Heating capacity maximal  
Pin nom: Power input at nominal heating capacity  
Pin min: Power input at minimal heating capacity  
Pin max: Power input at maximal heating capacity  
COP nom: coefficient of performance at nominal heating capacity  
Qc nom: cooling / heat extraction capacity at nominal heating capacity  
Qc min: cooling / heat extraction at minimal heating capacity  
Qc max: cooling / heat extraction at maximal heating capacity  
I nom: Current at nominal heating capacity  
EER: energy efficiency ratio at nominal cooling capacity

### Operating limits

Temp °C

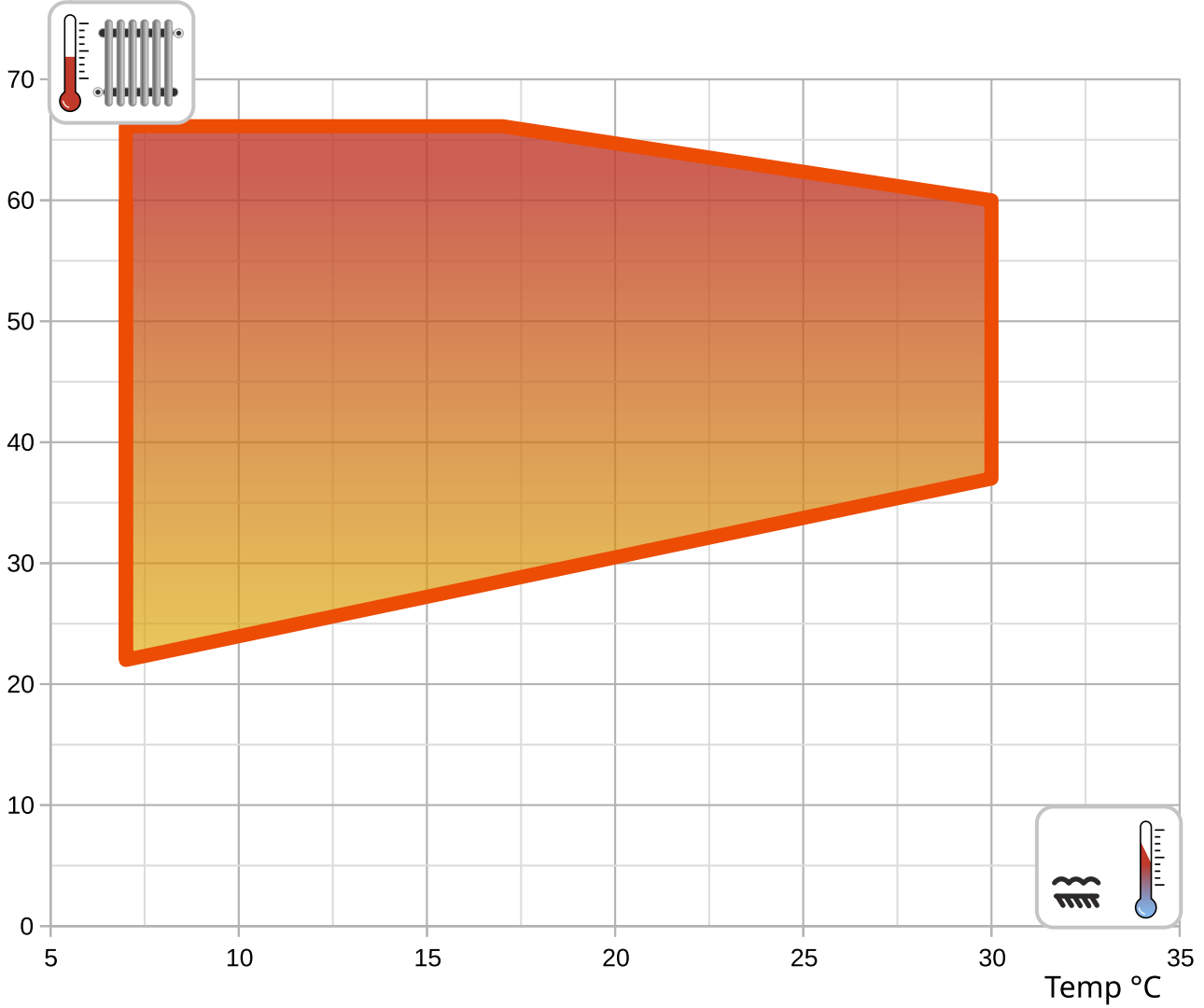

Temp °C

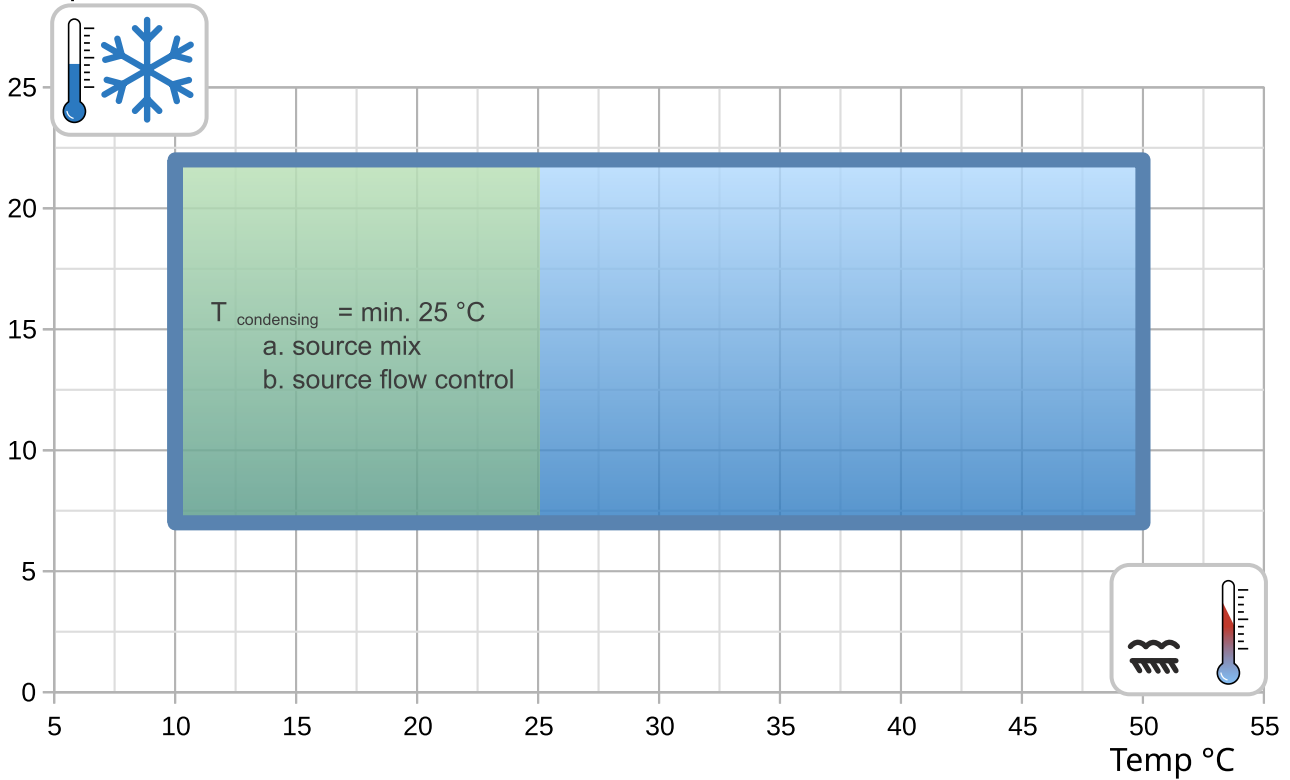

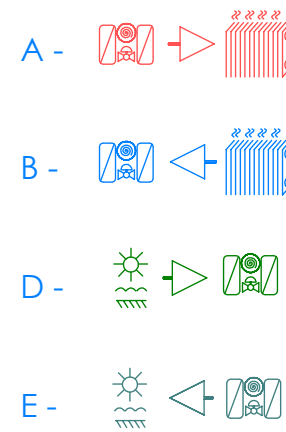
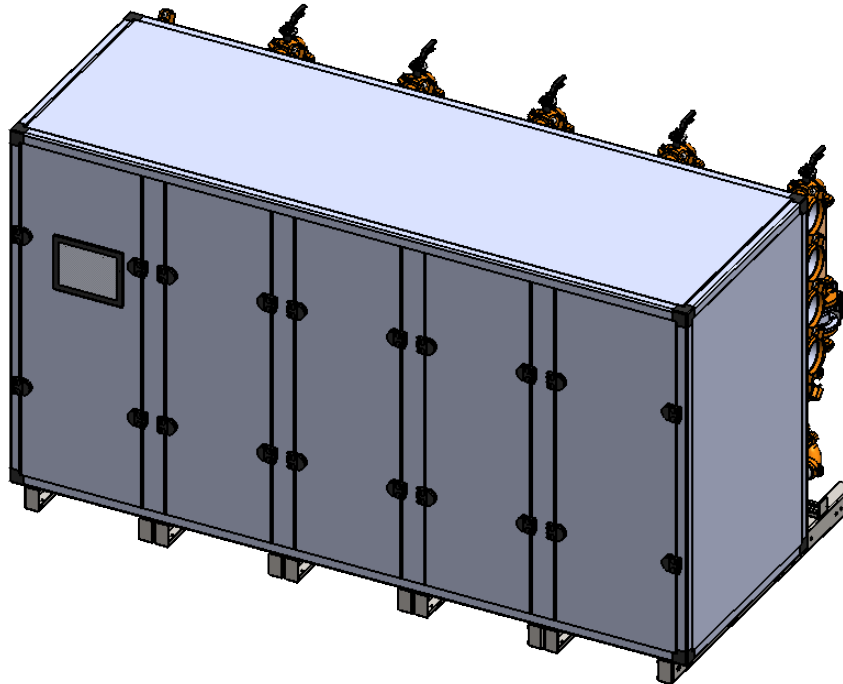
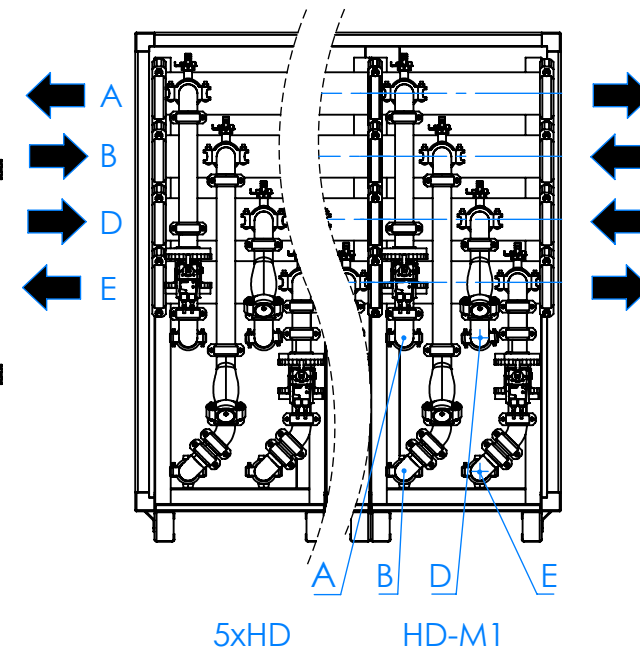
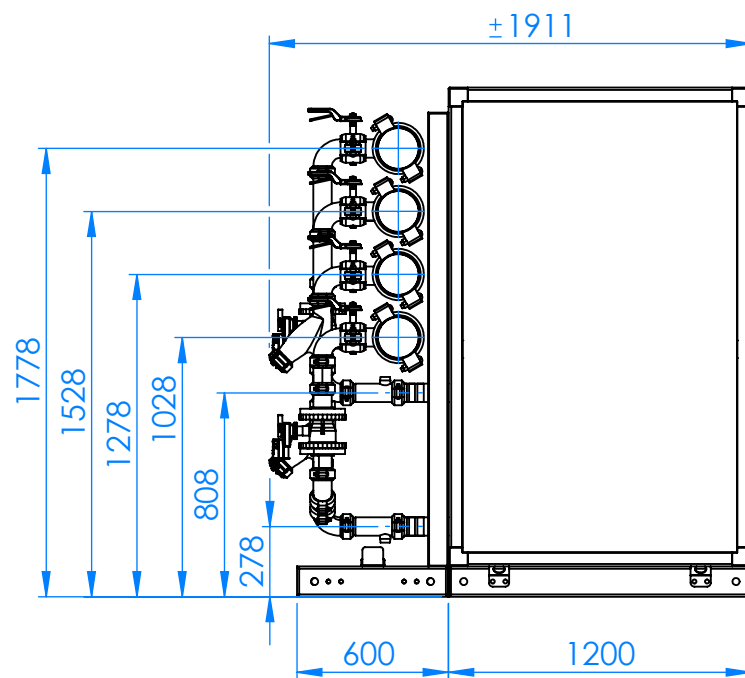
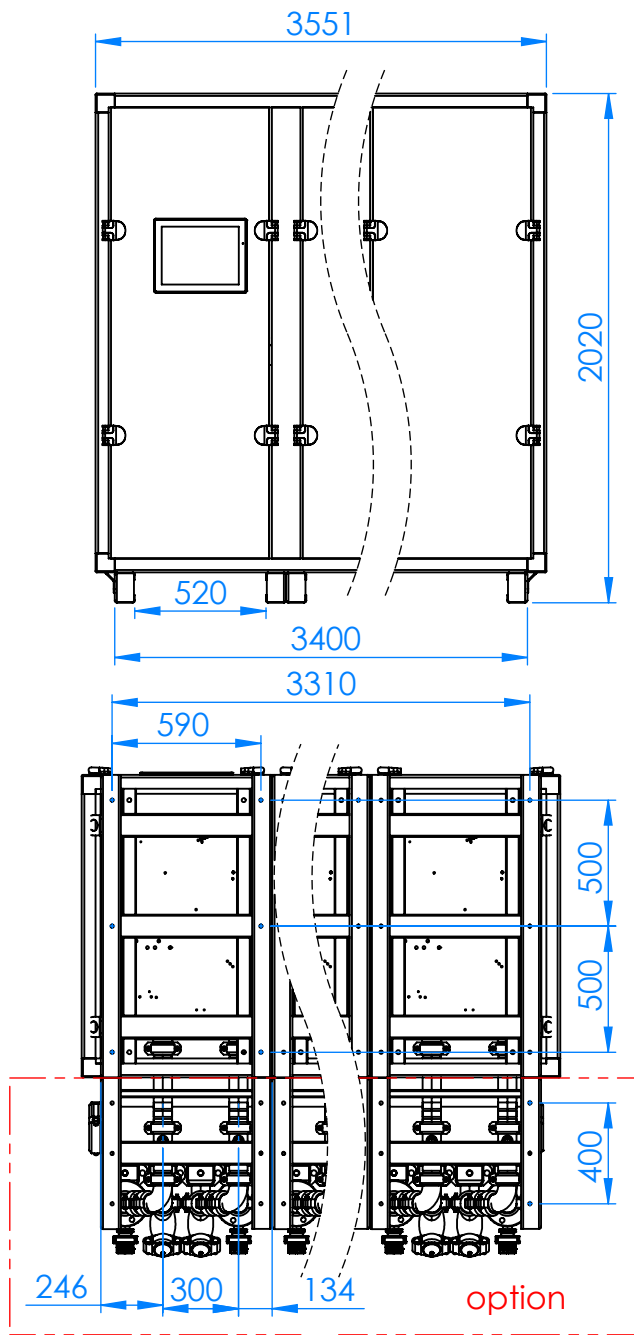



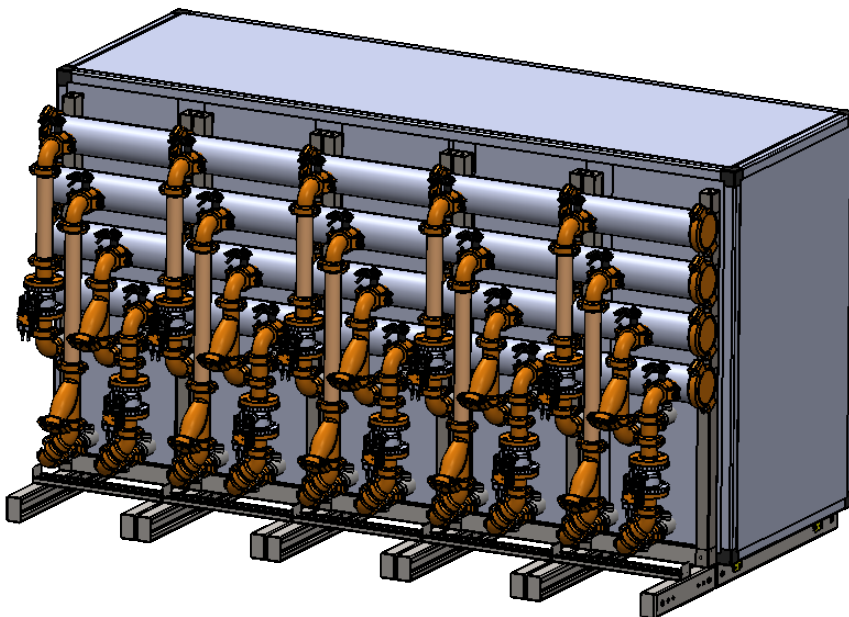
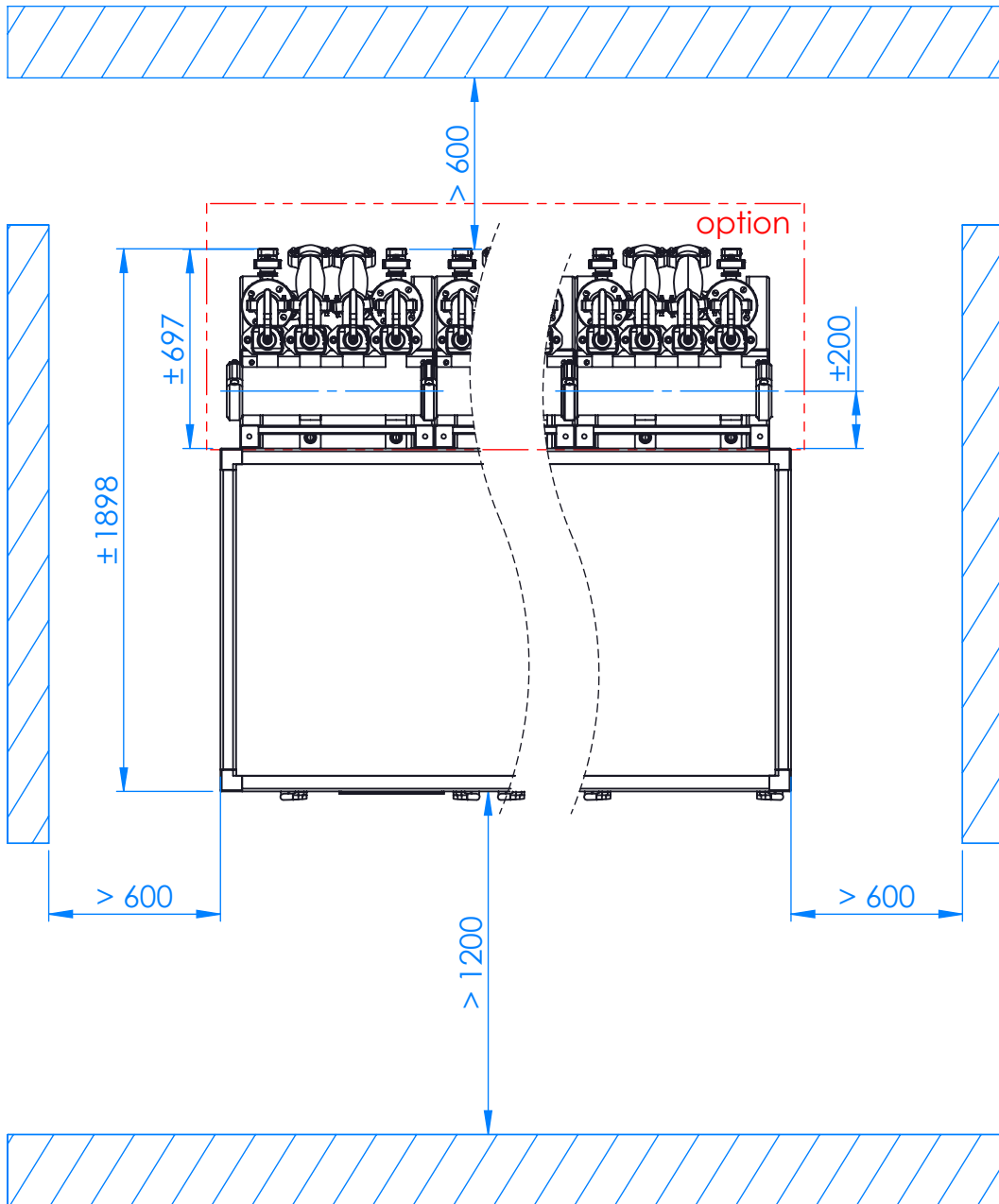

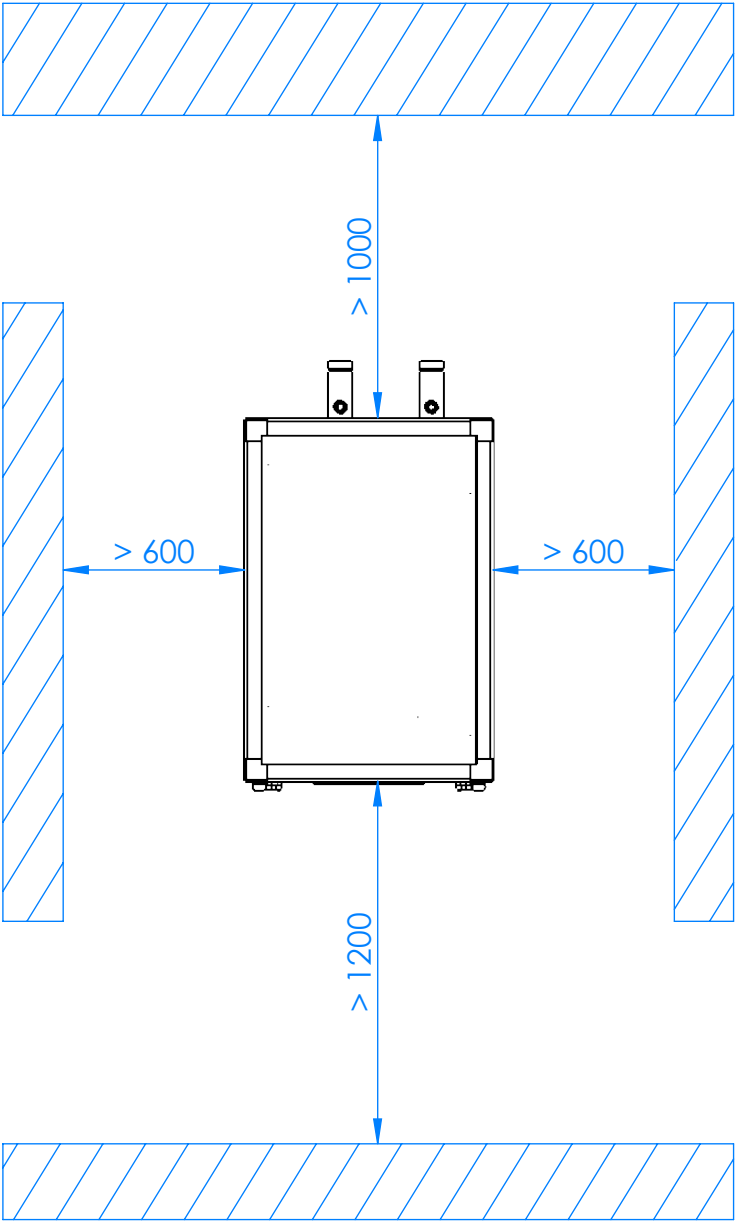

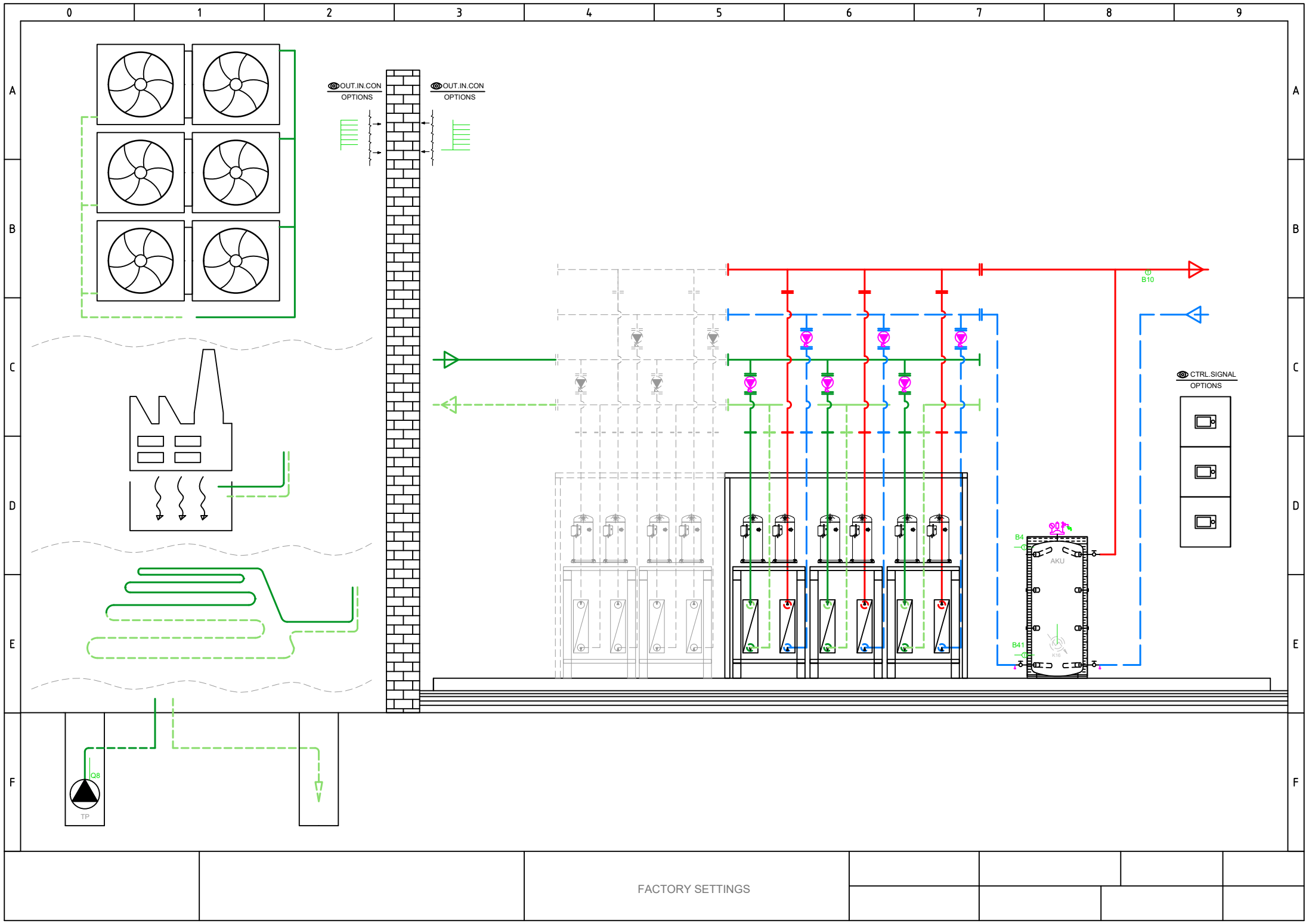

FACTORY SETTINGS

Total: max 6A  
1 x QX...: max 2A

Main power supply 230V / 50 Hz  
Ground  
Neutral conductor

- E9 Low-pressure switch E9
- E10 High-pressure switch E10
- E15 Flow switch source E15
- E24 Flow switch consumers E24
- E6 Electrical utility lock E6
- E12 Overload compressor 2 E12
- E21 Mains supervision E21
- E22 Mains supervision E22
- E23 Mains supervision E23
- E11 Overload compressor 1 E11
- K1 Compressor stage 1 K1

Q8 Source pump Q8

Q9 Condenser pump Q9

K10 Alarm output K10

K40 Crankcase heater K40

K81 Valve evaporator K81

K82 Valve EVI K82

K2 Compressor stage 2 K2

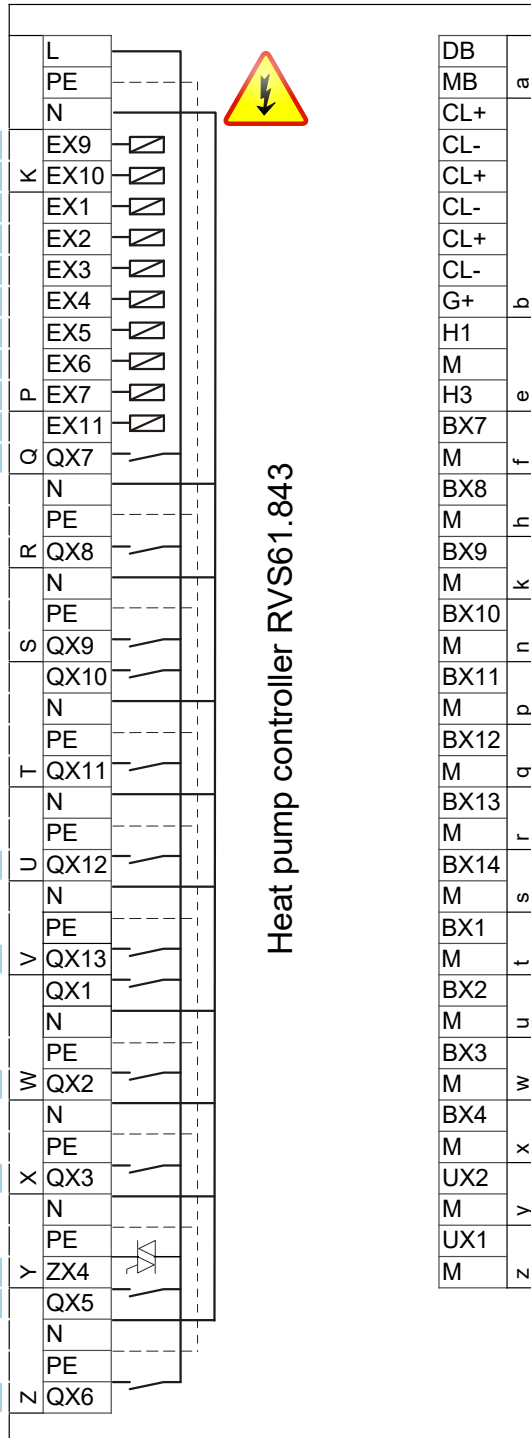

Heat pump controller RVS61.843

- DB LPB Bus data
- MB LPB Bus GND
- CL+ Room unit QAA...
- CL- Room unit QAA...
- CL+ Room unit QAA... 2.
- CL- Room unit QAA... 2.
- CL+ Room unit QAA... 3.
- CL- Room unit QAA... 3.
- G+ 12V supply → OUT
- H1
- M
- H3 Consumer request VK1
- BX7 B81 Hot-gas sensor K1 B81
- M
- BX8
- M
- BX9
- M B21 HP flow sensor B21
- BX10
- M
- BX11
- M
- BX12 B71 HP return sensor B71
- M
- BX13 B91 Source inlet sensor B91
- M
- BX14 B84 Source outl sens B92/B84
- M
- BX1
- M
- BX2
- M
- BX3 B83 Refrig sensor liquid B83
- M
- BX4 B82 Hot-gas sensor K2 B82
- M
- UX2 Condenser pump Q9
- M 0..10 V Signal
- UX1 Source pump Q8
- M 0..10 V Signal



- AVS75.390
- AVS75.391
- AVS75.370

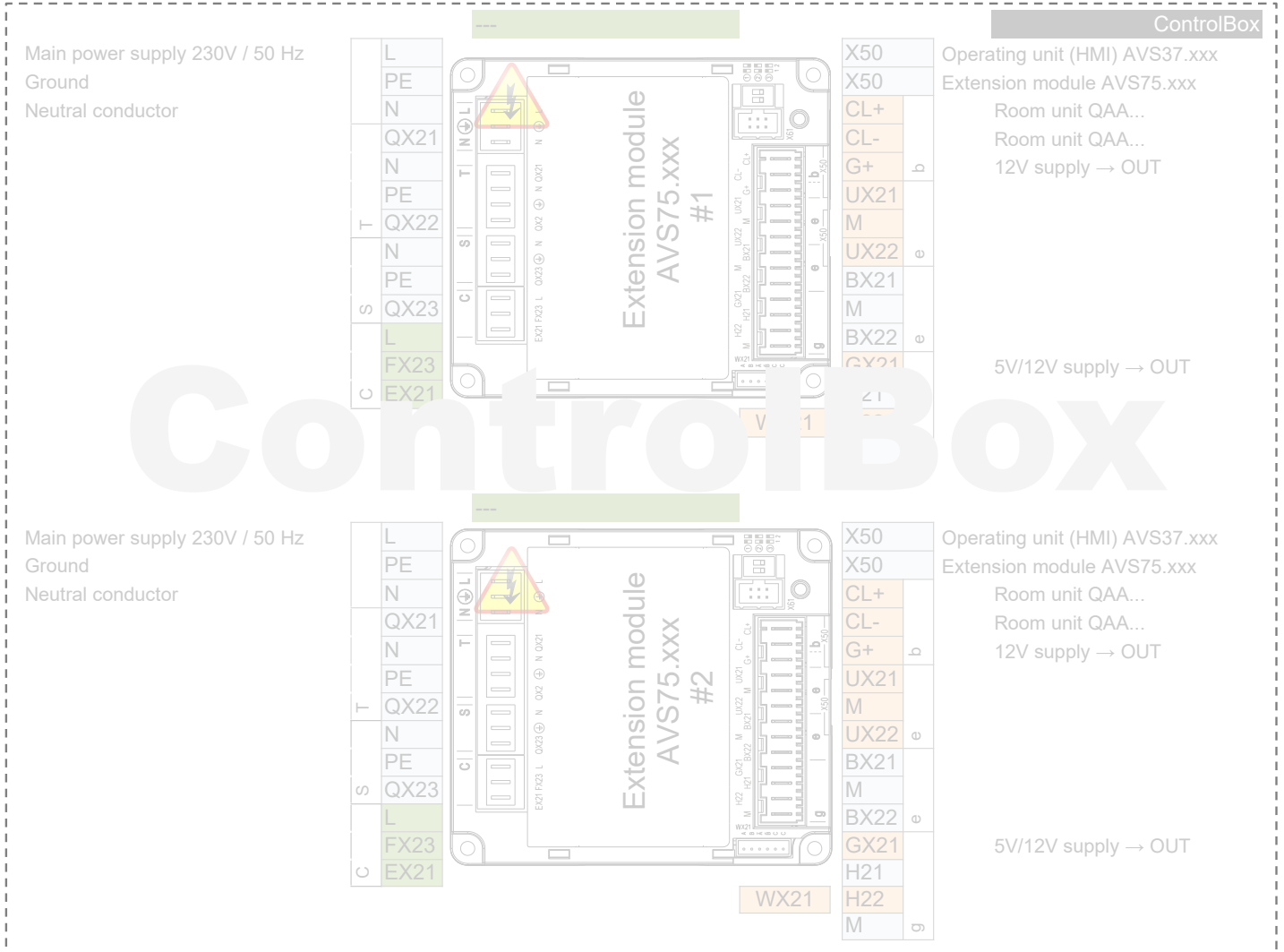

HEAT PUMP

EXTERNAL  
INTERNAL

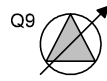
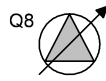

K1

K2

K82

K81

K40

K10

Q8 UX1

Q9 UX2

E11  
KRW1  
F1K  
E11

E12  
KRW2  
F2K  
E12

E6

Q9.ERR  
F1S  
E24

Q8.ERR  
F1Z  
E15

E10

E9

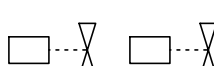

230V,50Hz  
max 6A

0...10V

230V,50Hz  
max 6A

0...10V

DO

DI

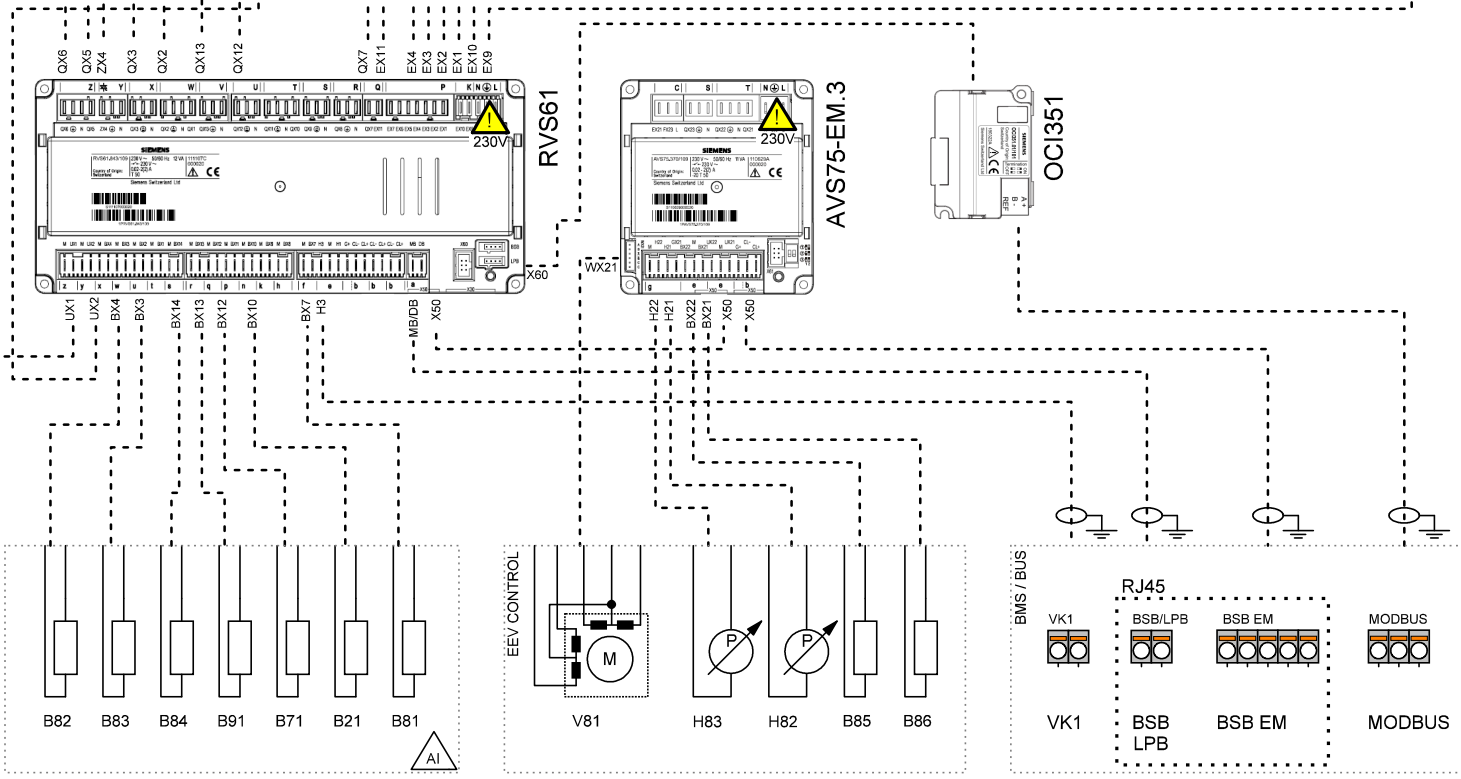
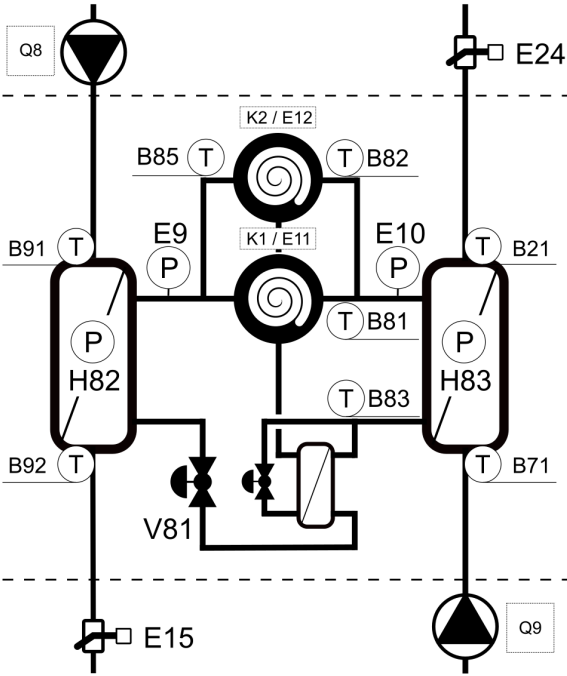

PWR SPLY: ..... 3~ 400V, 50 Hz  
CTRL: ..... 1~ 230V, 50 HZ

Company

Title  
TBW-TWW

Version / Note  
05/2024

Number

Created by

Date

Page  
1

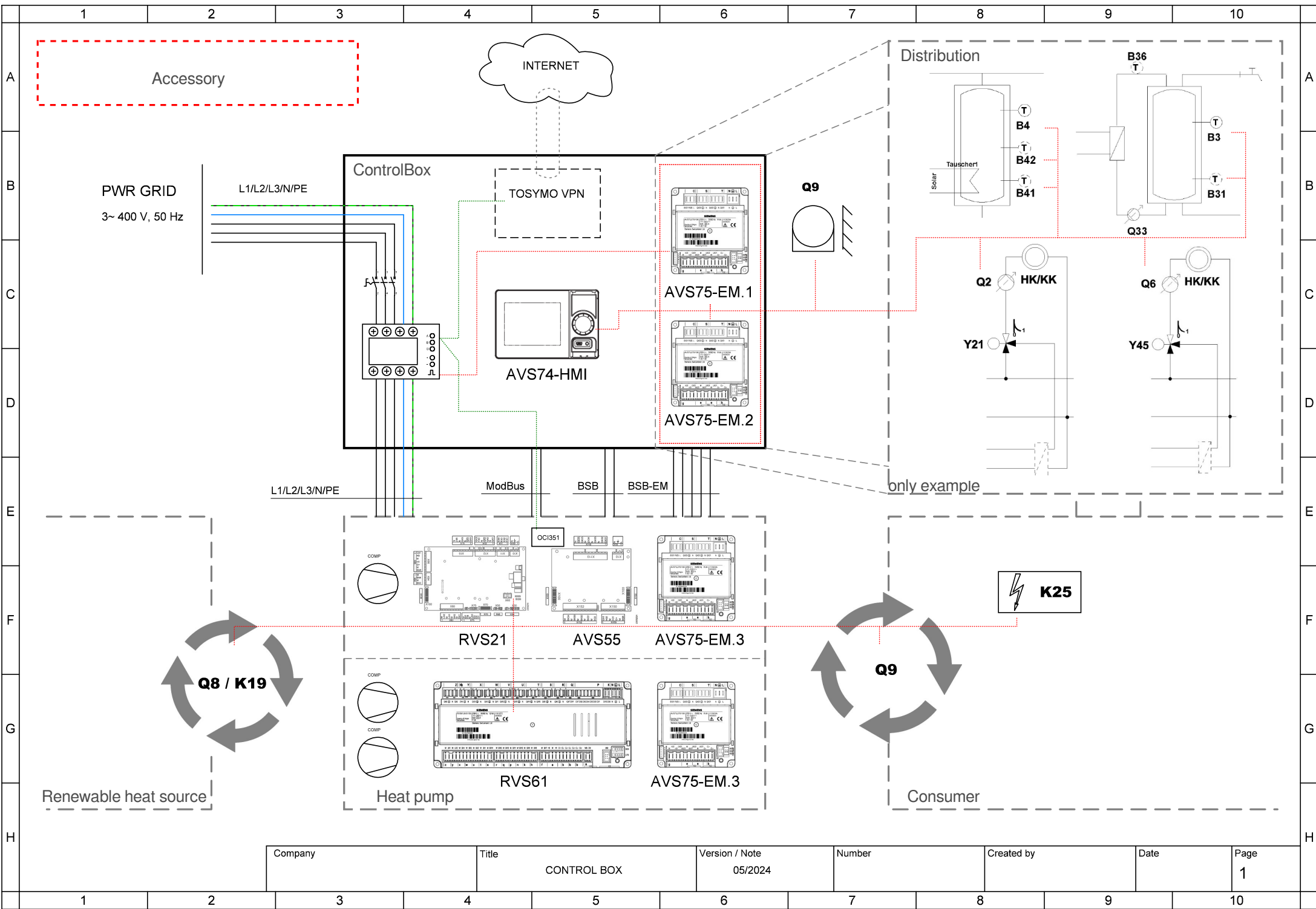

Company	Title	Version / Note	Number	Created by	Date	Page
	CONTROL BOX	05/2024				1



Company	Title	Version / Note	Number	Created by	Date	Page
	CONTROL BOX	05/2024				2





Company	Title	Version / Note	Number	Created by	Date	Page
	CONTROL BOX	05/2024				3



Company	Title	Version / Note	Number	Created by	Date	Page
	CONTROL BOX	05/2024				4

- AVS75.390
- AVS75.391
- AVS75.370

- AVS75.370**  
 Main power supply 230V / 50 Hz  
 Ground  
 Neutral conductor  
**Y1** Mixing valve Open  
  
**Y2** Mixing valve Close  
  
**Q2** Heat circuit pump HC1 Q2  
  
**L** Phase 230V  
**E61** Smart grid E61

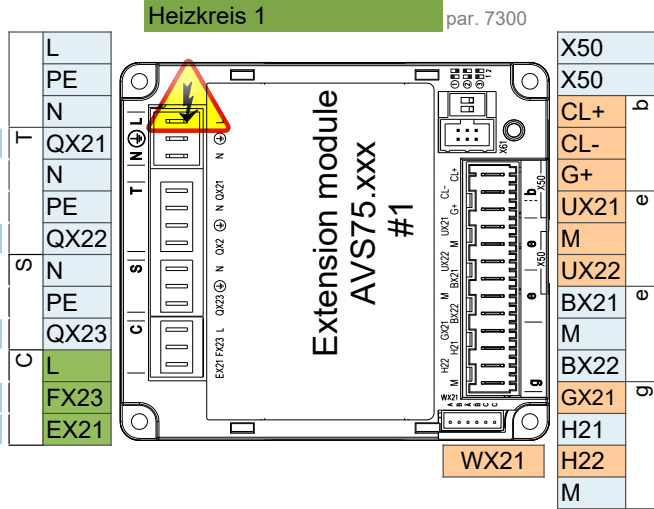

- Extension module AVS75.xxx  
 Room unit QAA...  
 Room unit QAA...  
  
**B1** Flow sensor 1  
  
 Pulse count

- AVS75.370**  
 Main power supply 230V / 50 Hz  
 Ground  
 Neutral conductor  
**Q3** DHW ctrl elem Q3  
  
**K6** El imm heater DHW K6  
  
**Q6** Heat circuit pump HC2 Q6  
  
**L** Phase 230V  
**E62** Smart grid E62

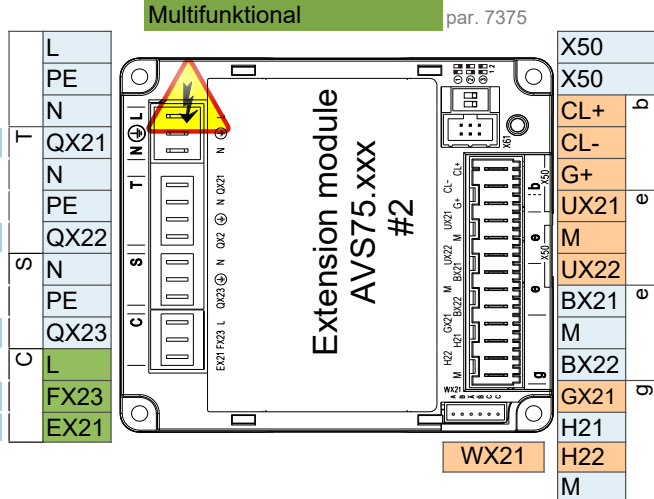

- Operating unit (HMI) AVS37.xxx  
 Extension module AVS75.xxx  
 Room unit QAA...  
 Room unit QAA...  
  
**B3** DHW sensor B3  
  
**B4** Buffer sensor B4

- Main power supply 230V / 50 Hz  
 Ground  
 Neutral conductor

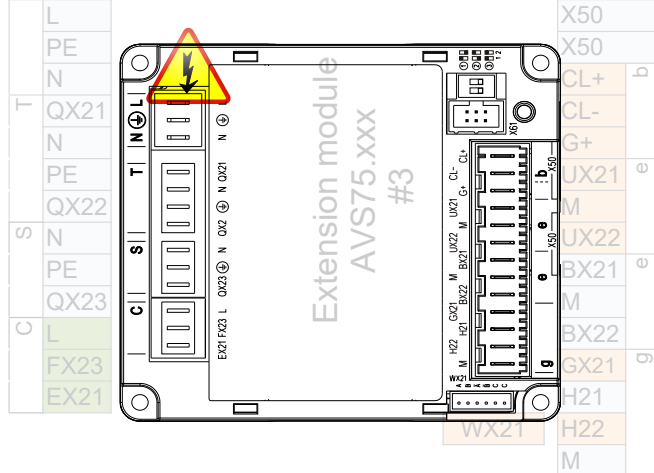

- Operating unit (HMI) AVS37.xxx  
 Extension module AVS75.xxx  
 Room unit QAA...  
 Room unit QAA...

Attention: Extension module 3 is inside the heat pump

## Control connection options

### 1 ControlBox

---

ControlBox, with two built-in extension modules, enables numerous options for application control on the consumer side behind the heat pump. For more, see the ControlBox schematic and the application diagrams sheet.

### 2 Fix flow temperature setpoint - On / Off dry (potential free) contact

---

2 wire shielded cable 2 x 0.5 mm<sup>2</sup> - Setpoint = 45°C (editable by param. 1859)

Connection terminal - see wiring diagram

### 3 Analog 0..10V flow temperature setpoint control

---

2 wire shielded cable 2 x 0.5 mm<sup>2</sup> - Setpoint: 0V = 16°C ~ 10V = 60°C ( editable in parameter set )

Connection terminal - see wiring diagram

### 4 ModBus RTU communication command

---

3 wire shielded cable min. 3 x 0.25mm<sup>2</sup>

For ModBus mapping table contact technical support

### 5 MQTT IoT communication protocol

---

For more information contact technical support